

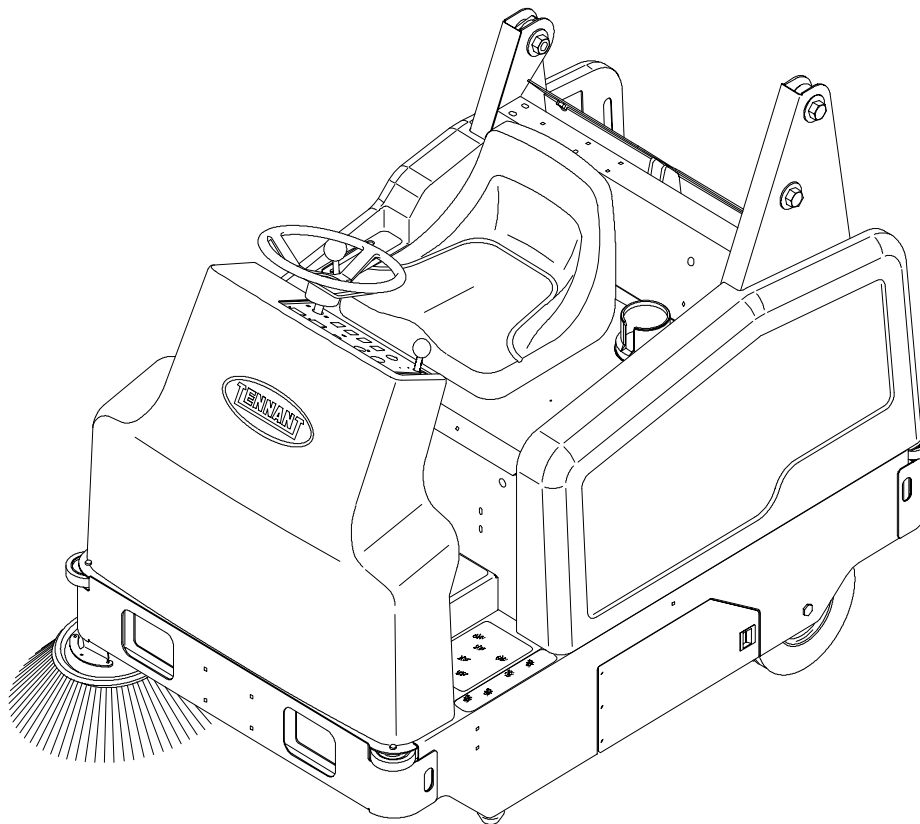

6200E

Service Manual



330415
Rev. 01 (12-01)



This service manual is intended to be used as an aid in the detailed service, repair, and troubleshooting of your TENNANT Model 6200E.

The set is organized into five major groups: General Information, Chassis, Sweeping, Electrical, and Hydraulics.

General Information: Safety precautions, machine specifications, machine maintenance chart, machine tying, machine jacking, machine storing, machine pushing or towing, and hardware information.

Chassis: Tire/wheel replacement, brake adjustment and replacement, steering adjustment and replacement.

Sweeping: V-belt replacement, brush replacement, bearing replacement, skirt/seal repair/replacement, and sweeping troubleshooting.

Electrical: Battery maintenance and replacement, electrical schematics, and electrical troubleshooting.

Hydraulics: Cylinder replacement/repair, pump replacement/repair, hydraulic schematic, and hydraulic troubleshooting.

Manual Number - 330415

Revision: 01

Published: 12-01

Copyright © 1999, 2001 TENNANT, Printed in U.S.A.

CONTENTS

	Page
SAFETY PRECAUTIONS	1-3
SPECIFICATIONS	1-5
GENERAL MACHINE	
DIMENSIONS/CAPACITIES	1-5
GENERAL MACHINE PERFORMANCE .	1-5
POWER TYPE	1-6
STEERING	1-6
HYDRAULIC SYSTEM	1-6
BRAKING SYSTEM	1-6
TIRES	1-6
MACHINE DIMENSIONS	1-7
MAINTENANCE	1-8
MAINTENANCE CHART	1-8
PUSHING, TOWING, AND	
TRANSPORTING THE MACHINE ..	1-10
PUSHING OR TOWING THE	
MACHINE	1-10
TRANSPORTING THE MACHINE ..	1-10
MACHINE JACKING	1-12
STORING MACHINE	1-12
HARDWARE INFORMATION	1-13
STANDARD BOLT TORQUE CHART ..	1-13
METRIC BOLT TORQUE CHART	1-13
BOLT IDENTIFICATION	1-13
THREAD SEALANT AND LOCKING	
COMPOUNDS	1-13
HYDRAULIC FITTING INFORMATION	1-14
HYDRAULIC TAPERED PIPE FITTING	
(NPT) TORQUE CHART	1-14
HYDRAULIC TAPERED SEAT FITTING	
(JIC) TORQUE CHART	1-14
HYDRAULIC O-RING FITTING	
TORQUE CHART	1-14
MACHINE TROUBLESHOOTING	1-15

SAFETY PRECAUTIONS

The following symbols are used throughout this manual as indicated in their description:



WARNING: To warn of hazards or unsafe practices that could result in severe personal injury or death.

FOR SAFETY: To identify actions that must be followed for safe operation of equipment.

The machine is suited to sweep disposable debris. Do not use the machine other than described in this Operator Manual. The machine is not designed for use on public roads.

The following information signals potentially dangerous conditions to the operator or equipment:

FOR SAFETY:

1. **Do not operate machine:**
 - Unless trained and authorized.
 - Unless operation manual is read and understood.
 - In flammable or explosive areas unless designed for use in those areas.
 - In areas with possible falling objects unless equipped with overhead guard.
2. **Before starting machine:**
 - Make sure all safety devices are in place and operate properly.
 - Check brakes and steering for proper operation.
3. **When starting machine:**
 - Keep foot on brake and directional pedal in neutral.
4. **When using machine:**
 - Use brakes to stop machine.
 - Go slowly on inclines and slippery surfaces.
 - Use care when reversing machine.
 - Make sure adequate clearance is available before raising hopper.
 - Move machine with care if hopper is raised.
 - Do not carry riders on machine.
 - Always follow safety and traffic rules.
 - Report machine damage or faulty operation immediately.

5. **Before leaving or servicing machine:**
 - Stop on level surface.
 - Set parking brake.
 - Turn off machine and remove key.
6. **When servicing machine:**
 - Avoid moving parts. Do not wear loose jackets, shirts, or sleeves when working on machine.
 - Block machine tires before jacking up machine.
 - Jack up machine at designated locations only. Block machine up with jack stands.
 - Use hoist or jack that will support the weight of the machine.
 - Wear eye and ear protection if using pressurized air or water.
 - Disconnect battery connections before working on machine.
 - Avoid contact with battery acid.
 - Use Tennant supplied or equivalent replacement parts.
7. **When loading/unloading machine onto/off truck or trailer:**
 - Turn off machine.
 - Use truck or trailer that will support the weight of the machine.
 - Use winch. Do not drive the machine onto/off the truck or trailer unless the load height is 380 mm (15 in) or less from the ground.
 - Set parking brake after machine is loaded.
 - Block machine tires.
 - Tie machine down to truck or trailer.



WARNING: Batteries emit hydrogen gas. Explosion or fire can result. Keep sparks and open flame away. Keep covers open when charging.



WARNING: Lift arm pinch point. Stay clear of hopper lift arms.



WARNING: Raised hopper may fall. Engage hopper support bar

GENERAL INFORMATION

The following safety labels are mounted on the machine in the locations indicated. If these or any labels become damaged or illegible, install a new label in its place.



FOR SAFETY LABEL - LOCATED ON THE SIDE OF THE OPERATOR COMPARTMENT.

BATTERY CHARGING LABEL - LOCATED IN BATTERY COMPARTMENT.

BATTERY CHARGING LABEL - LOCATED ON SEAT MOUNTING WELDMENT

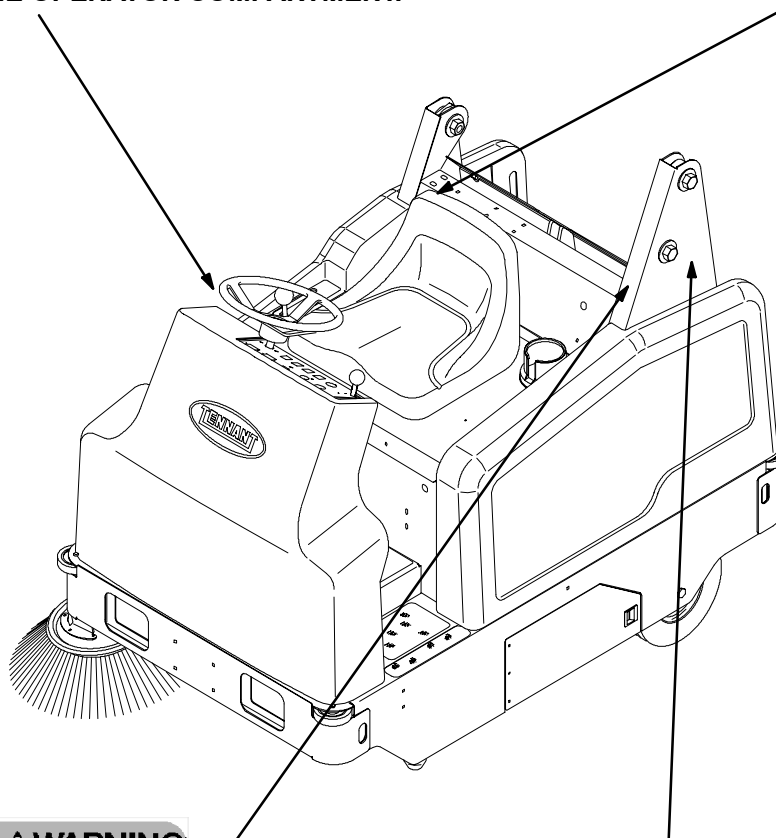
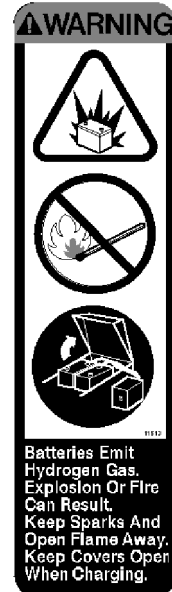

HOPPER LIFT ARMS LABEL - LOCATED ON BOTH LIFT ARMS.

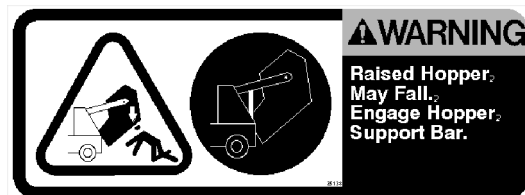

HOPPER SUPPORT LABEL - LOCATED ON INSIDE METAL PANEL ON BOTH SIDES OF MACHINE.

SPECIFICATIONS

GENERAL MACHINE DIMENSIONS/CAPACITIES

Item	Dimension/capacity	
Length	1956 mm	(77 in)
Width	1070 mm	(43 in)
Width w/side brush	1120 mm	(45 in)
Height	1440 mm	(57 in)
Height with overhead guard	2045 mm	(82 in)
Track	94 mm	(37 in)
Wheelbase	97 mm	(38 in)
Main sweeping brush diameter	203 mm	(8 in)
Main sweeping brush length	711 mm	(28 in)
Side brush diameter	520 mm	(20.5 in)
Sweeping path width	711 mm	(28 in)
Sweeping path width with one side brush	1070 mm	(42 in)
Sweeping path width with two side brushes	1400 mm	(55 in)
Main sweeping brush pattern width	65 mm	(2.5 in)
Hopper weight capacity	135 kg	(300 lb)
Hopper volume capacity	125 L	(4.4 cu ft)
Dust filter area	4.6 sq m	(49 sq ft)
GVWR	927 kg	(2060 lb)
Ceiling height minimum dumping clearance	2286 mm	(90 in)

GENERAL MACHINE PERFORMANCE

Item	Measure	
Maximum forward speed	9.7 km/h	(6 mph)
Maximum reverse speed	4.8 km/h	(3 mph)
Minimum aisle turn	2095 mm	(82.5 in)
Minimum turning radius, left	1400 mm	(55 in)
Minimum turning radius, right	1400 mm	(55 in)
Maximum rated incline with empty hopper	10°/18%	
Maximum rated incline with full hopper	6°/11%	

GENERAL INFORMATION

POWER TYPE

Type	Quantity	Volts	Ah Rating	Weight
Batteries	6	6	220 @ hr rate	177 kg (390lbs)
Batteries	6	6	235 @ hr rate	177 kg (390lbs)
Batteries	6	6	335 @ hr rate	310 kg (625lbs)

Type	Use	VDC	Kw (hp)
Electric Motor	Propelling	36	1.1 kW (1.5 hp)

Type	VDC	A	Hz	Phase	VAC
Charger	36	20	60	1	240

STEERING

Type	Power source	Emergency steering
Front wheel, manual controlled	Manual steering	Manual

HYDRAULIC SYSTEM

System	Capacity	Fluid Type
Hydraulic reservoir	.53 L (.14 gal)	TENNANT part no. 65870
Hydraulic total	1.4 L (.37 gal)	

BRAKING SYSTEM

Type	Operation
Service brakes	Mechanical disc brake (1), one front wheel, cable actuated
Parking brake	Utilizes service brakes, cable actuated

TIRES

Location	Type	Size
Front (1)	Solid	102 x 305 mm (4 in x12 in OD)
Rear (2)	Solid	76 x 305 mm (3 in x 12 in OD)

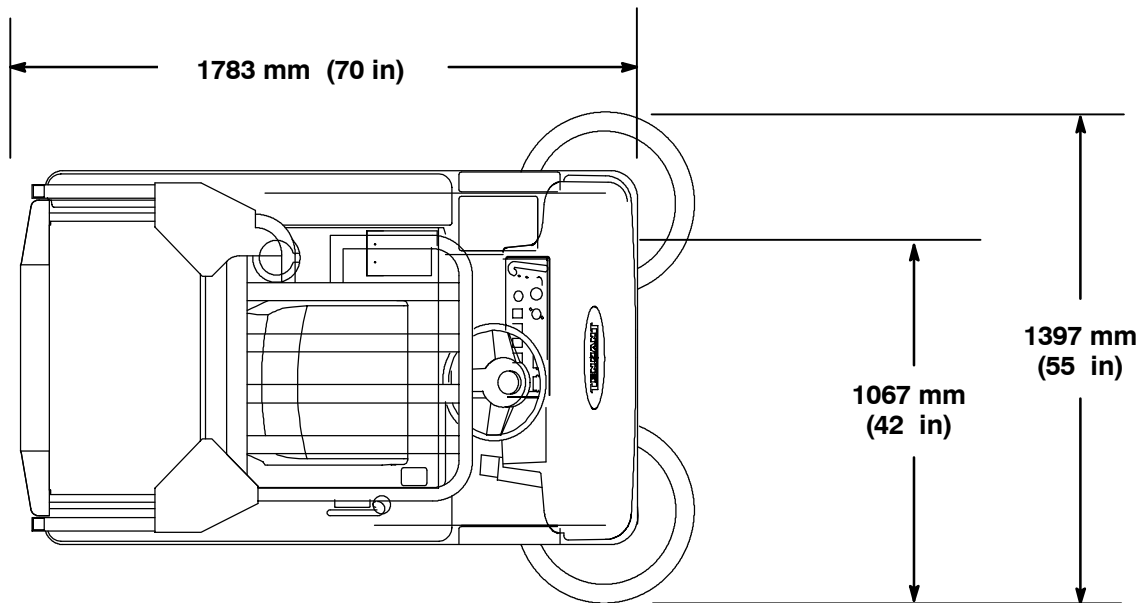

TOP VIEW

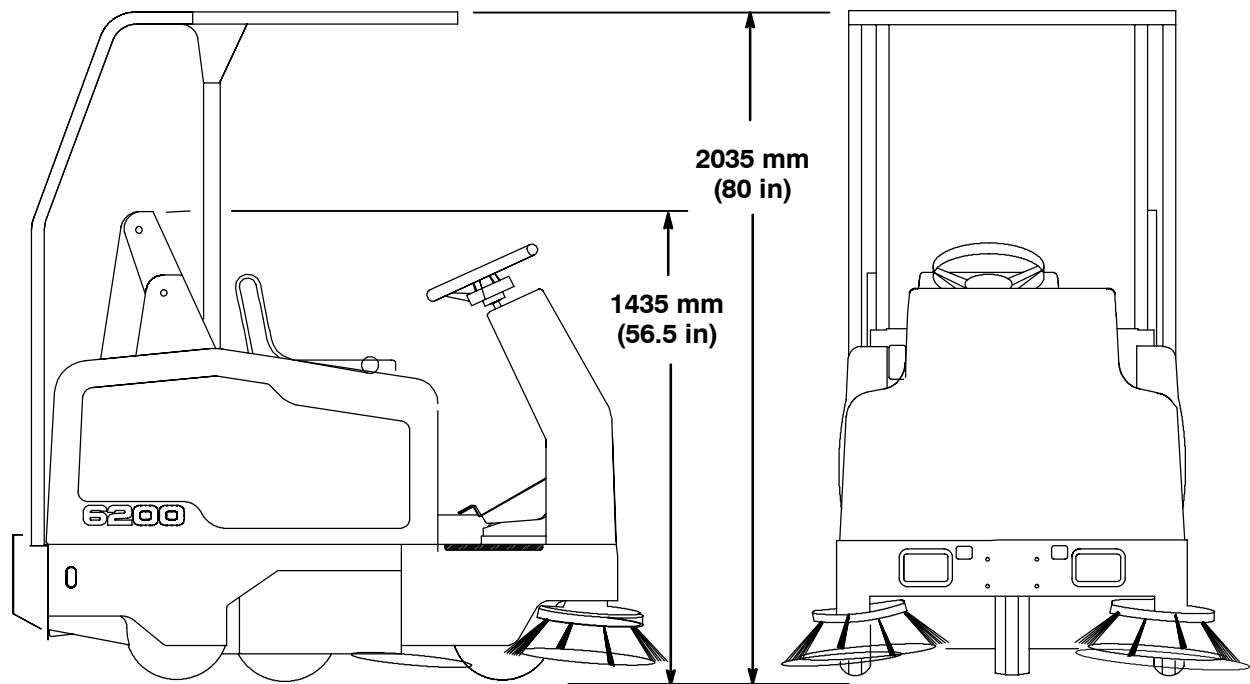

SIDE VIEW

FRONT VIEW

MACHINE DIMENSIONS

352945

MAINTENANCE

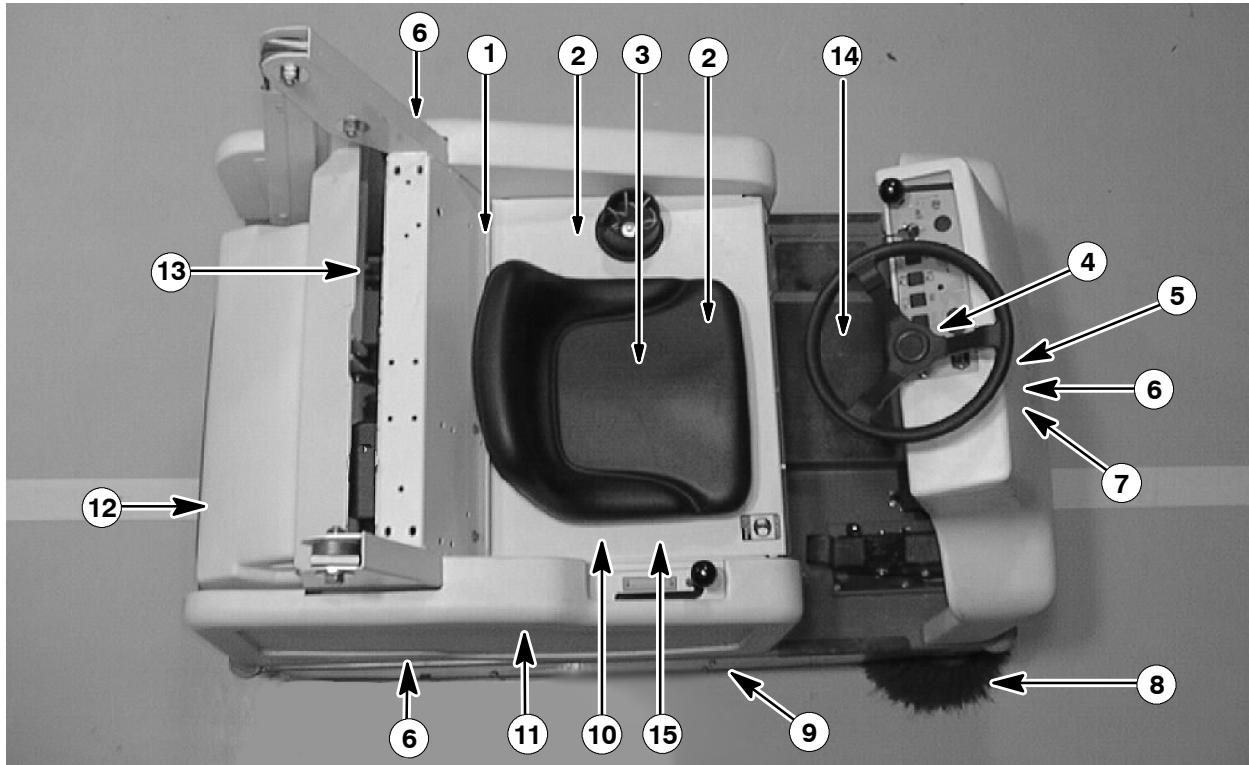

MAINTENANCE CHART

Interval	Key	Description	Procedure	Lubricant/ Fluid	No. of Service Points
Daily	2	Brush compartment skirts	Check for damage, wear and adjustment	-	5
	14	Side skirts	Check for damage, wear and adjustment	-	2
	10	Main brush	Check for damage, wear and adjustment	-	1
				-	1
	8	Side brush(es)	Check for damage or wear	-	1
Check brush pattern			-	1	
12	Hopper dust filter	Shake	-	1	
50 Hours	10	Main brush	Rotate end-for-end	-	1
	-	QuickMop™ broom (Option)	Rotate or wash sweep heads	-	2
	3	Batteries	Check electrolyte level	DW	6 (3)
	-	Vacuum wand bag (Option)	Check or change vacuum bag	-	1
	-	Vacuum wand fan (Option)	Check for damage or wear	-	1

GENERAL INFORMATION

Interval	Key	Description	Procedure	Lubricant/ Fluid	No. of Service Points
100 Hours	12	Hopper dust filter	Change for damage, clean or replace	-	1
	13	Hydraulic reservoir	Check fluid level	HYDO	1
	6	Tires	Check for damage	-	3
	1	Hopper seals	Check for damage or wear	-	6
	1	Hopper filter seals	Check for damage or wear	-	2
	12	Vacuum seal	Check for damage or wear	-	1
	2	Large debris trap skirt	Check for damage or wear	-	1
	7	Steering castor pivot bearing	Lubricate and check for wear	SPL	1
	11	Vacuum fan belt	Check tension and wear	-	1
	9	Main brush belt	Check for wear	-	1
200 Hours	5	Brakes	Check and adjust travel	-	1
	4	Steering gear chain	Lubricate	EO	1
	8	Side brush(es) guard	Check for damage or wear	-	1 (2)
	3	Battery terminals and cables	■ Check and clean	-	12
800 Hours	13	Hydraulic fluid reservoir	Change hydraulic fluid	HYDO	1
	13	Hydraulic hoses	Check for wear and damage	-	2
	7	Propelling motor	Check carbon brushes	-	1
	6	Rear wheels	■ Check rear wheel axle torque	-	1
	15	Main brush motor	Check carbon brushes	-	1

LUBRICANT/FLUID

DW . . . Distilled water

EO . . . SAE 30 Engine oil

HYDO . Tennant or approved hydraulic fluid

SPL . . . Special lubricant, Lubriplate EMB grease (TENNANT part no. 01433-1)

NOTE: Also check procedures indicated (■) after the first 50 hours of operation.

NOTE: More frequent intervals may be required in extremely dusty conditions.

GENERAL INFORMATION

PUSHING, TOWING, AND TRANSPORTING THE MACHINE

PUSHING OR TOWING THE MACHINE

If the machine becomes disabled, it can be pushed or towed from the front or rear, but it is easier and more stable to tow from the front end.

Only push or tow the machine for a *very short distance* and do not exceed 3.2 kp/h (2 mph). It is NOT intended to be pushed or towed for a long distance or at a high speed.

ATTENTION! Do not push or tow machine for a long distance or damage may occur to the propelling system.

TRANSPORTING THE MACHINE

1. Position the front of the machine at the loading edge of the truck or trailer.

FOR SAFETY: Use truck or trailer that will support the weight of the machine.

NOTE: Empty the hopper before transporting the machine.

2. If the loading surface is not horizontal or is higher than 380 mm (15 in) from the ground, use a winch to load machine.

If the loading surface is horizontal AND is 380 mm (15 in) or less from the ground, the machine may be driven onto the truck or trailer.

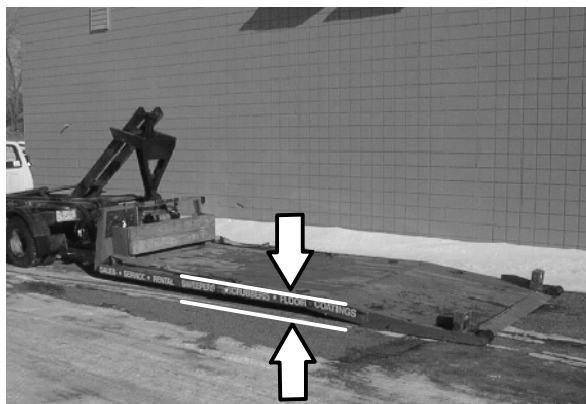

3. To winch the machine onto the truck or trailer, attach the winching chains to the front tie down located in the front of the machine frame.

FOR SAFETY: When loading machine onto truck or trailer, use winch. Do not drive the machine onto the truck or trailer unless the loading surface is horizontal AND is 380 mm (15 in) or less from the ground.

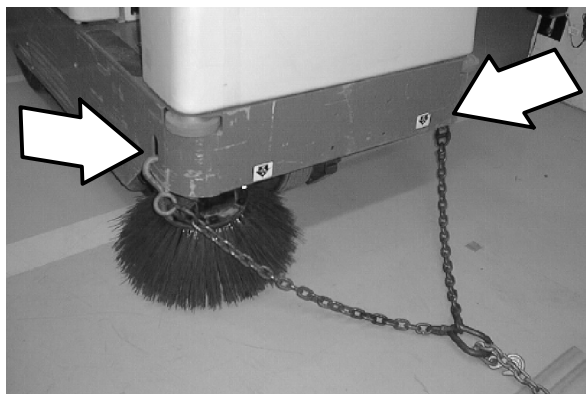

4. Position the machine onto the truck or trailer as far as possible. If the machine starts to veer off the centerline of the truck or trailer, stop and turn the steering wheel to center the machine.
5. Set the parking brake and block the machine tires. Tie down the machine to the truck or trailer before transporting.

The front tie-down locations are the holes in the front of the machine frame.

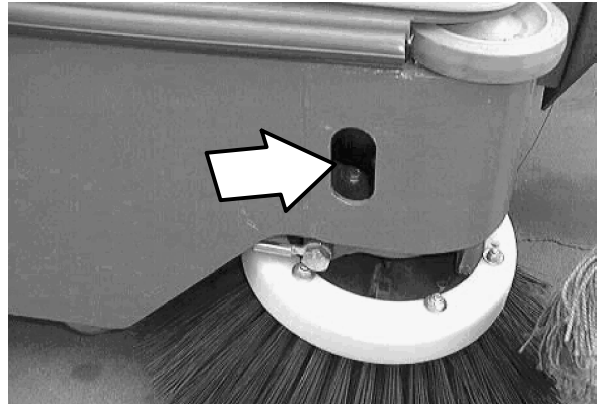

The rear tie-down locations are the holes in the sides of the machine frame near the rear bumper.



6. If the loading surface is not horizontal or is higher than 380 mm (15 in) from the ground, use a winch to unload machine.

If the loading surface is horizontal AND is 380 mm (15 in) or less from the ground, the machine may be driven off the truck or trailer.

FOR SAFETY: When unloading machine off truck or trailer, use winch. Do not drive the machine off the truck or trailer unless the loading surface is horizontal AND 380 mm (15 in) or less from the ground.

GENERAL INFORMATION

MACHINE JACKING

Empty the hopper before jacking the machine. You can jack up the machine for service at the designated locations. Use a hoist or jack that will support the weight the machine. Always stop the machine on a flat, level surface and block the tires before jacking up the machine.

FOR SAFETY: Before leaving or servicing machine, stop on level surface, set parking brake, turn off machine, and remove key.

The front jacking locations are on the flat bottom edge of the front of the machine frame.

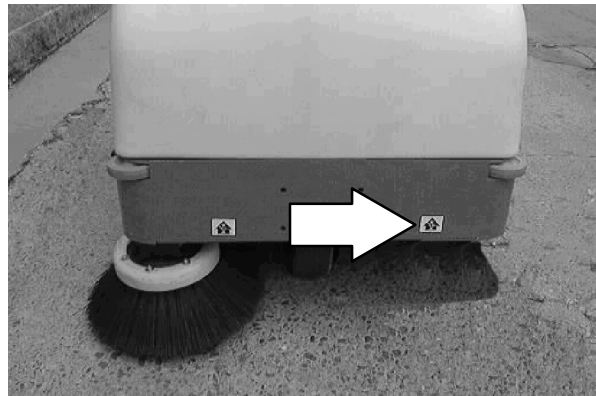

The rear jacking locations are on the corners of the rear frame.

FOR SAFETY: When servicing machine, block machine tires before jacking up machine.

FOR SAFETY: When servicing machine, jack up machine at designated locations only. Block machine up with jack stands.

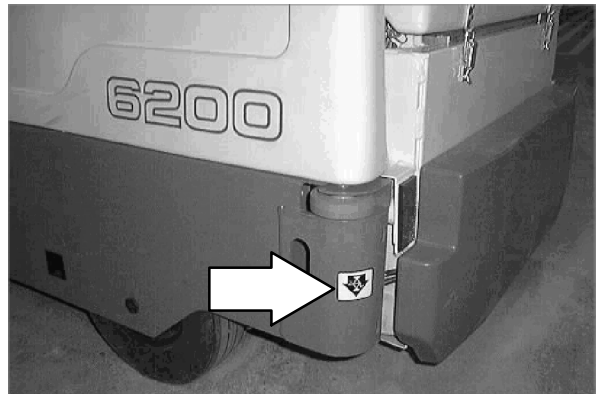

STORING MACHINE

Before storing the machine for an extended time, the machine needs to be serviced to lessen the chance of rust, sludge, and other undesirable deposits from forming.

HARDWARE INFORMATION

The following charts state standard plated hardware tightening ranges for normal assembly applications. Decrease the specified torque by 20% when using a thread lubricant. Do not substitute lower grade hardware for higher grade hardware. If higher grade hardware than specified is substituted, tighten only to the specified hardware torque value to avoid damaging the threads of the part being threaded into, as when threading into speed nuts or weldments.

NOTE: Decrease torque by 20% when using a thread lubricant.

Exceptions to the above chart:





Check the machine for exceptions!

STANDARD BOLT TORQUE CHART

Thread Size	SAE Grade 5 Torque ft lb (Nm)	SAE Grade 8 Torque ft lb (Nm)
0.25 in	7-10 (9-14)	10-13 (14-38)
0.31 in	15-20 (20-27)	20-26 (27-35)
0.38 in	27-35 (37-47)	36-47 (49-64)
0.44 in	43-56 (58-76)	53-76 (72-103)
0.50 in	65-85 (88-115)	89-116 (121-157)
0.62 in	130-170 (176-231)	117-265 (159-359)
0.75 in	215-280 (291-380)	313-407 (424-552)
1.00 in	500-650 (678-881)	757-984 (1026-1334)

NOTE: Decrease torque by 20% when using a thread lubricant.

BOLT IDENTIFICATION

Identification Grade Marking	Specification and Grade
	SAE-Grade 5
	SAE-Grade 8
	ISO-Grade 8.8
	ISO-Grade 10.9

01395

THREAD SEALANT AND LOCKING COMPOUNDS

Thread sealants and locking compounds may be used on this machine. They include the following:

Loctite 515 sealant - gasket forming material. TENNANT Part No. 75567, 15 oz (440 ml) cartridge.

Loctite 242 blue - medium strength thread locking compound. TENNANT Part No. 32676, 0.5 ml tube.

Loctite 271 red - high strength thread locking compound. TENNANT Part No. 19857, 0.5 ml tube.

METRIC BOLT TORQUE CHART

Thread Size	Class 8.8 Torque ft lb (Nm)	Class 10.9 Torque ft lb (Nm)
M4	2 (3)	3 (4)
M5	4 (5)	6 (8)
M6	7 (9)	10 (14)
M8	18 (24)	25 (34)
M10	32 (43)	47 (64)
M12	58 (79)	83 (112)
M14	94 (127)	133 (180)
M16	144 (195)	196 (265)
M20	260 (352)	336 (455)
M24	470 (637)	664 (900)

GENERAL INFORMATION

HYDRAULIC FITTING INFORMATION

HYDRAULIC TAPERED PIPE FITTING (NPT) TORQUE CHART

NOTE: Ratings listed are when using teflon thread seal.

Size	Minimum Torque	Maximum Torque
1/4 NPT	10 ft lb (14 Nm)	30 ft lb (41 Nm)
1/2 NPT	25 ft lb (34 Nm)	50 ft lb (68 Nm)
3/4 NPT	50 ft lb (68 Nm)	100 ft lb (136 Nm)

HYDRAULIC TAPERED SEAT FITTING (JIC) TORQUE CHART

Tube O.D. (in)	Thread Size	Maximum Torque
0.25	0.44-20	9 ft lb (12 Nm)
0.38	0.56-18	20 ft lb (27 Nm)
0.50	0.75-16	30 ft lb (41 Nm)
0.62	0.88-14	40 ft lb (54 Nm)
0.75	1.12-12	70 ft lb (95 Nm)
1.0	1.31-12	90 ft lb (122 Nm)

HYDRAULIC O-RING FITTING TORQUE CHART

Tube O.D. (in)	Thread Size	Minimum Torque	Maximum Torque
0.25	0.44-20	6 ft lb (8 Nm)	9 ft lb (12 Nm)
0.38	0.56-18	13 ft lb (18 Nm)	20 ft lb (27 Nm)
		*10 ft lb (14 Nm)	12 ft lb (16 Nm)
0.50	0.75-16	20 ft lb (27 Nm)	30 ft lb (41 Nm)
		*21 ft lb (28 Nm)	24 ft lb (33 Nm)
0.62	0.88-14	25 ft lb (34 Nm)	40 ft lb (54 Nm)
0.75	1.12-12	45 ft lb (61 Nm)	70 ft lb (95 Nm)
1.0	1.31-12	60 ft lb (81 Nm)	90 ft lb (122 Nm)

NOTE: Do not use sealant on o-ring threads.

*Aluminum bodied components

MACHINE TROUBLESHOOTING

Problem	Cause	Remedy
No machine power	Power kill switch on	Turn kill switch clockwise until it pops up. Turn machine off and on
	Hopper dust filter clogged	Shake and or clean or replace dust filter
Low machine power	Low battery power	Check and charge batteries
Machine does not propel	Operator not in seat	Sit in operator seat
Excessive dusting	Vacuum fan off	Press the main brush, vacuum and filter shaker switch to the on position
	Brush skirts and dust seals worn, damaged, out of adjustment	Replace or adjust brush skirts or dust seals
	Hopper dust filter clogged	Shake and/or clean or replace dust filter
	Vacuum fan failure	Contact Tennant service personnel
	Thermo Sentry™ tripped	Reset Thermo Sentry™
	Hopper door partially or completely closed	Open hopper door
Poor sweeping performance	Brush bristles worn	Replace brushes
	Main and side brushes not adjusted properly	Adjust main and side brushes
	Debris caught in main brush drive mechanism	Remove debris from drive mechanism
	Main brush drive failure	Contact Tennant service personnel
	Side brush drive failure	Contact Tennant service personnel
	Hopper full	Empty hopper
	Hopper lip skirts worn or damaged	Replace lip skirts
	Wrong sweeping brush	Contact Tennant representative for recommendations
	Large debris trap damaged	Repair or replace large debris trap
	Hopper dust filter clogged	Shake and/or clean or replace dust filter
	Hopper door partially or completely closed	Open the hopper door
	Recirculation flap damaged	Replace flap

CONTENTS

	Page		Page
INTRODUCTION	2-3	PLANETARY GEAR BOX	2-29
OPERATOR SEAT	2-4	TO REMOVE PLANETARY GEAR	
ADJUSTABLE OPERATOR SEAT		BOX	2-29
(OPTION)	2-4	TO INSTALL PLANETARY GEAR	
OPERATOR SAFETY SWITCH	2-4	BOX	2-31
STATIC DRAG CHAIN	2-5	TO REPLACE FRONT TIRE AND	
BRAKES AND TIRES	2-5	WHEEL ASSEMBLY	2-33
SERVICE BRAKES	2-5	TO REPLACE FRONT DRIVE	
PARKING BRAKE	2-5	ASSEMBLY OUTER WHEEL	
TO ADJUST SERVICE BRAKES ..	2-6	BEARING	2-37
TO ADJUST PARKING BRAKE ...	2-7	TO REPLACE FRONT DRIVE	
TO REPLACE DRIVE ASSEMBLY		ASSEMBLY INNER WHEEL	
BRAKE SHOES	2-8	BEARING	2-39
REAR TIRES AND WHEELS	2-12	STEERING	2-43
TO REMOVE REAR TIRE	2-12	TO ADJUST STEERING CHAIN	2-43
TO INSTALL REAR TIRE	2-13	TO REPLACE STEERING CHAIN ...	2-44
TO REPLACE REAR WHEEL		TO REPLACE LARGE STEERING	
BEARINGS	2-14	SPROCKET	2-45
FRONT TIRE AND WHEEL, AND		TO REPLACE SMALL STEERING	
WHEEL DRIVE SUPPORT	2-16	SPROCKET	2-47
FRONT WHEEL SUPPORT		TO REPLACE STEERING HOUSING	
CASTER BEARING ASSEMBLY .	2-16	BEARINGS	2-49
TO REMOVE FRONT DRIVE		TO REPLACE STEERING U-JOINT .	2-53
ASSEMBLY	2-17		
TO INSTALL FRONT DRIVE			
ASSEMBLY	2-19		
TO REPLACE DRIVE ASSEMBLY			
CASTER BEARING AND			
THRUST WASHERS	2-21		
TO REPLACE DRIVE ASSEMBLY			
PIVOT CONE BEARING	2-26		

INTRODUCTION

This section includes information on the main chassis related components, for example; the seat, steering, front drive assembly, brakes and tires.

CHASSIS

SEAT

OPERATOR SEAT

The standard operators seat is a stationary fixed back style.



ADJUSTABLE OPERATOR SEAT (OPTION)

The optional operators seat is a fixed back style with a forward-backward adjustment.

Adjust: Pull the lever in, slide the seat backward or forward to the desired position, and release the lever to lock the seat in place.



OPERATOR SAFETY SWITCH

The operator seat has a safety switch that stops the machine from propelling unless the operator is sitting in the operator's seat.



STATIC DRAG CHAIN

A static drag chain prevents the buildup of static electricity in the machine. The chain is attached to the machine by a rear main brush skirt retaining bolt.

Make sure the chain is touching the floor at all times.

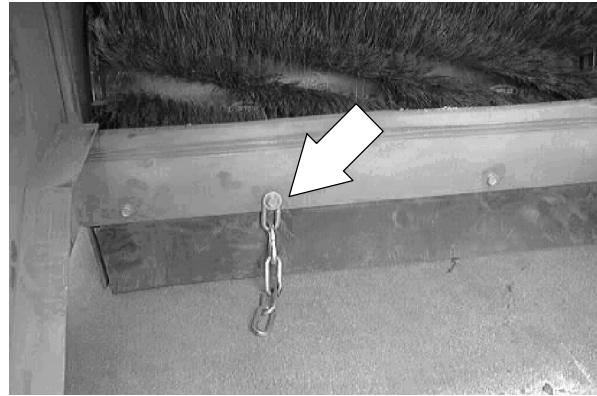

BRAKES AND TIRES

SERVICE BRAKES

The service brake is located on the front wheel assembly. It is actuated with a foot brake pedal in the operators compartment.

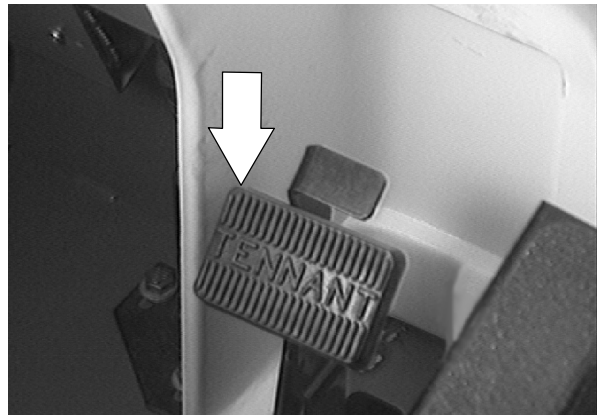
**PARKING BRAKE**

The parking brake is located on the front wheel assembly. It is actuated with a smaller toe lever on the top of the foot brake pedal in the operators compartment. It is deactivated by simply pushing on the foot brake pedal.

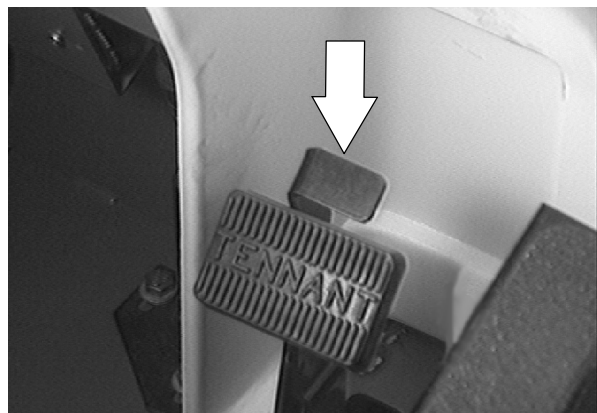

CHASSIS

TO ADJUST SERVICE BRAKES

The service brakes should be adjusted when an excessive amount of brake pedal stroke is needed to stop the machine.

FOR SAFETY: Before Leaving Or Servicing Machine; Stop On Level Surface, Block Rear Wheels.

1. Go under the machine in the front right corner.

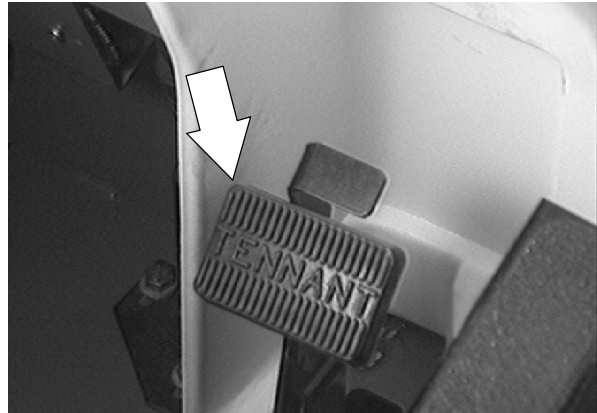

2. Locate the area where the brake cable attaches to the drive support. The beginning adjustment should be **1.375 in.** of conduit showing on the cable end.

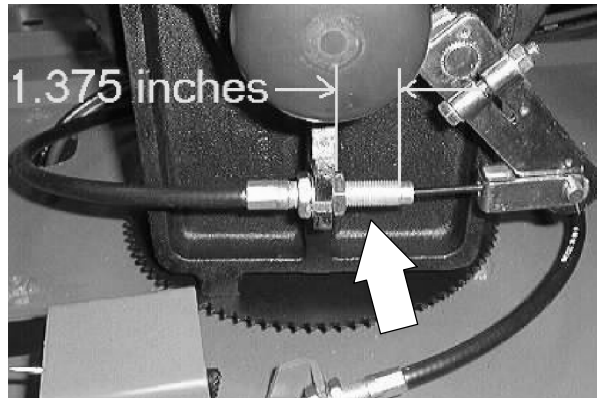

3. Turn the steering wheel all the way to the right.

NOTE: Spin the tire/wheel assembly to make sure the brakes are not dragging with the brake pedal NOT engaged.

4. Loosen the two jam nuts on the brake cable, where it attaches to the drive support casting.
5. Move the cable away from the brake lever far enough to remove the slack in the pedal movement.
6. Re-tighten the two jam nuts firmly. Operate the machine and check the brake pedal for a shorter stroke.

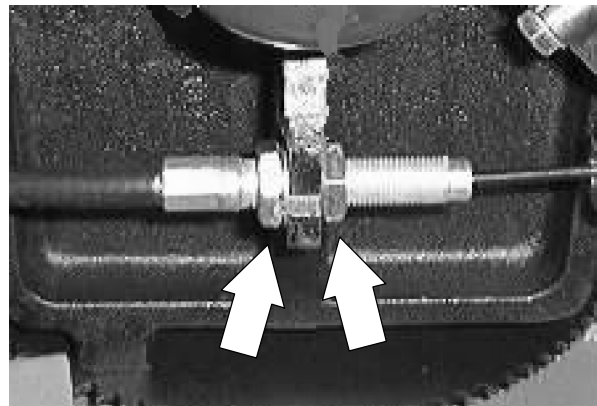

TO ADJUST PARKING BRAKE

The parking brake should be adjusted when an excessive amount of brake pedal stroke is needed to hold the machine.

FOR SAFETY: Before Leaving Or Servicing Machine; Stop On Level Surface, Block Rear Wheels.

1. Go under the machine in the front right corner.

2. Locate the area where the brake cable attaches to the drive support. The beginning adjustment should be **1.375 in.** of conduit showing on the cable end.

3. Turn the steering wheel all the way to the right.

NOTE: Spin the tire/wheel assembly to make sure the brakes are not dragging with the brake pedal NOT engaged.

4. Loosen the two jam nuts on the brake cable, where it attaches to the drive support casting.
5. Move the cable away from the brake lever far enough to remove the slack in the pedal movement.
6. Re-tighten the two jam nuts firmly. Operate the machine and check the brake pedal for a shorter stroke.

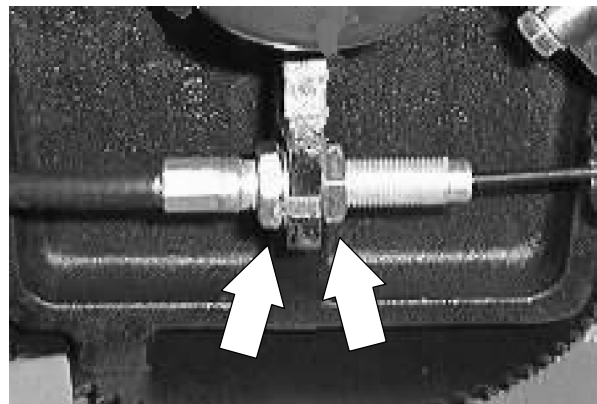
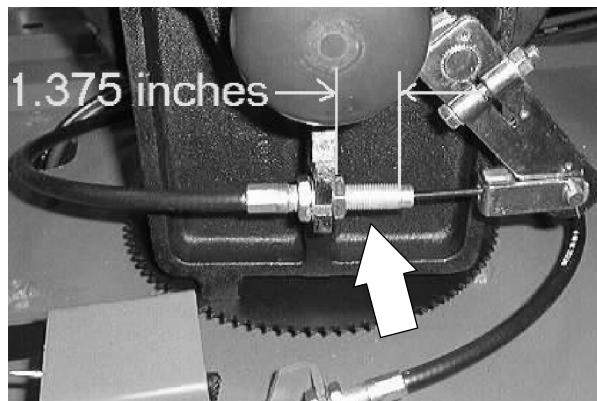
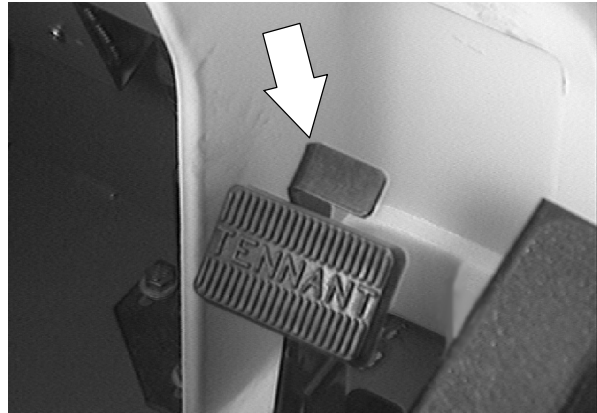

CHASSIS

TO REPLACE DRIVE ASSEMBLY BRAKE SHOES

The front brake shoes should be replaced when the machine no longer stops easily or the adjustment in the brake cable has been used up.

FOR SAFETY: Before Leaving Or Servicing Machine; Stop On Level Surface, Block Rear Wheels.

1. Raise the seat support and unplug the battery connectors.
2. Raise the front of the machine and place jack stands under the frame.
3. Mark and remove the electrical cables leading to the drive motor.
4. Remove the four hex screws holding the outer plate, motor, and planetary gear box to the main drive assembly.
5. Pull the planetary gear box, outer plate, and motor out of the drive wheel and away from the drive assembly.

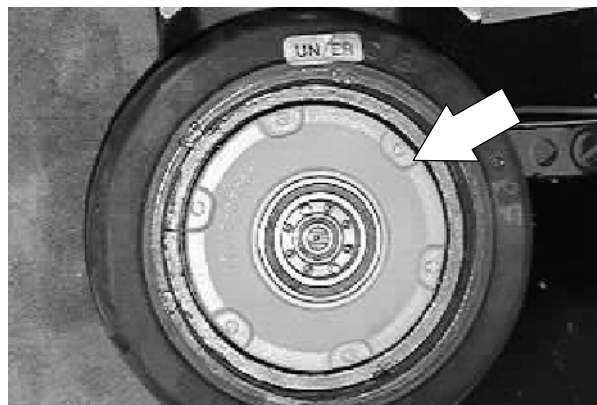
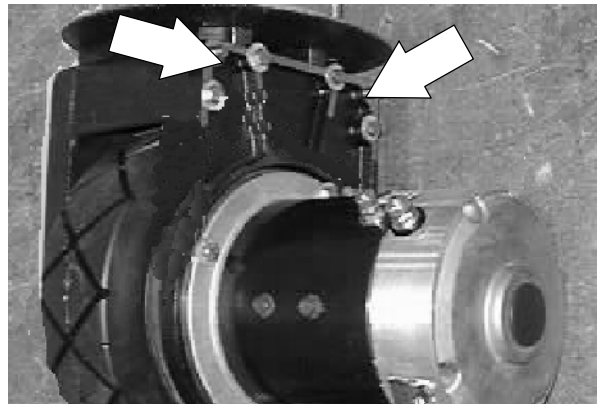
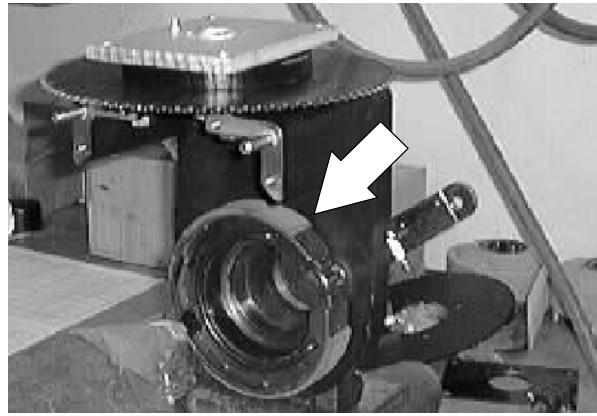

- Go to the other side of the drive assembly and remove the hub cap. This will expose the outer bearing, hex sleeve, and lock bolt.

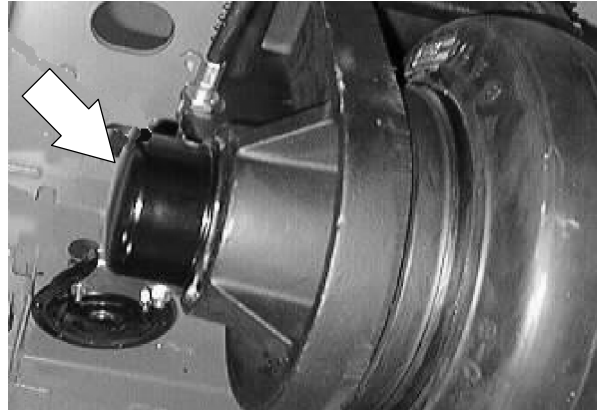

- Remove the lock bolt.
(this is a right-hand thread screw).
- Remove the hex sleeve and outer bearing cone assembly.
(this is a left hand thread nut).
- The axle/tire/wheel assembly can now be removed from the drive assembly. This will expose the brake shoes.

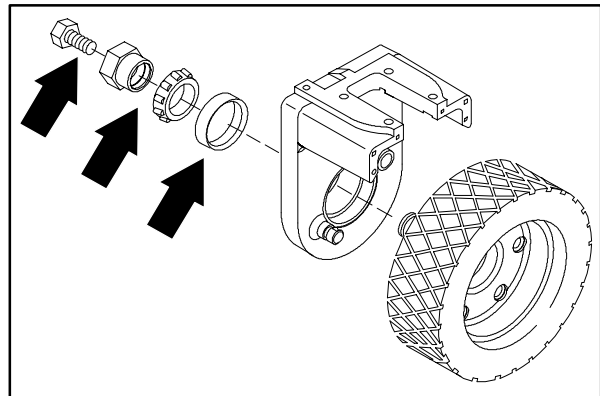

- Loosen the two jam nuts on the brake cable, where it attaches to the drive support casting. Pull the brake cable off the drive assembly.

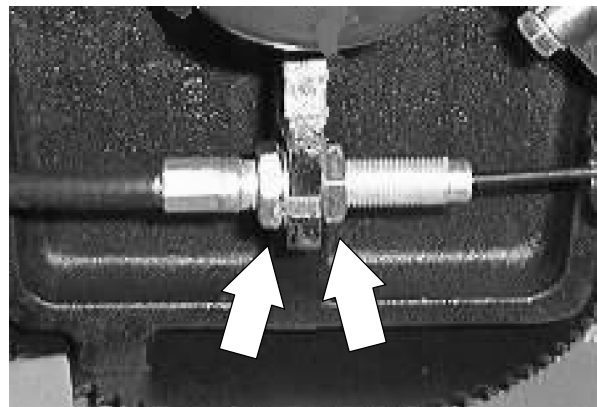

- Remove the large "C" spring holding the two brake shoes together. Remove the brake shoes.

NOTE: There is a great deal of tension on the "C" spring. Care must be used when spreading the spring for removal or installation.

- Install the new brake shoes on the drive assembly in the same orientation as the old ones were removed.
- Reinstall the "C" spring on the new brake shoes.

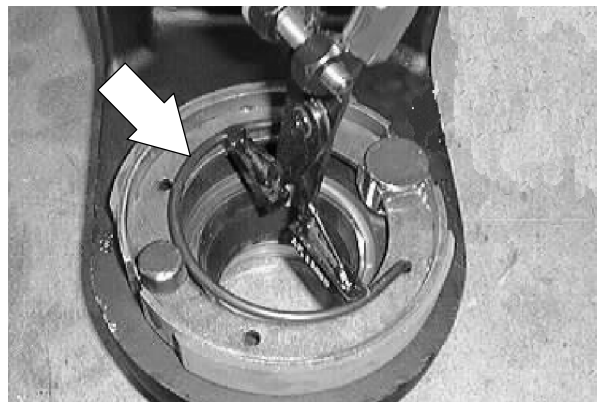

CHASSIS

14. Reinstall the axle/tire/wheel assembly into the drive assembly. Make sure the inner and outer wheel bearings are completely greased when re-assembling.

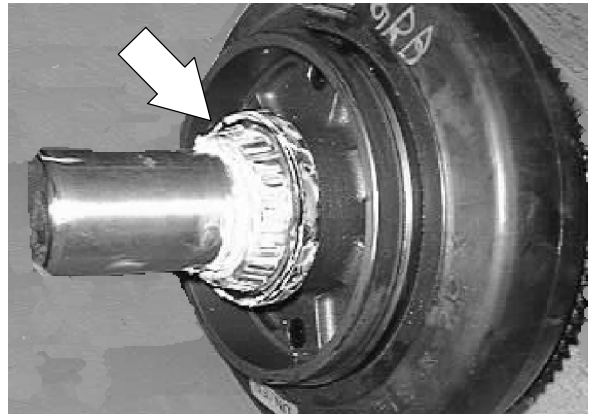

15. Reinstall the outer bearing and hex sleeve assembly (**this is a left hand thread nut**). Tighten to at least 100 ft lbs and then back off the hex sleeve to 0 ft lbs. Re-torque hex sleeve to 30 ft lbs.

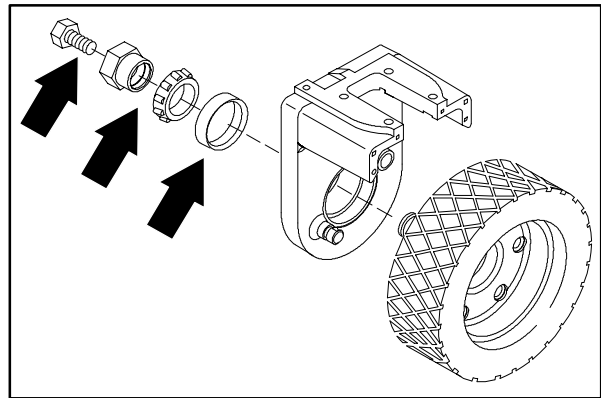

16. Install the lock bolt in the end of the hex sleeve. Tighten the lock bolt to 200 Nm (150 ft lb) while holding the hex sleeve from turning.

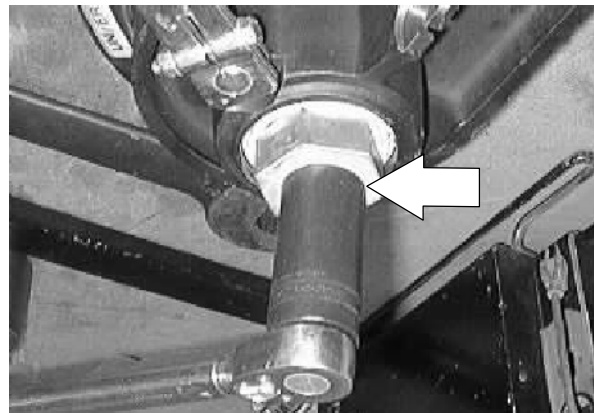

17. Reinstall the hub cap in the drive assembly.

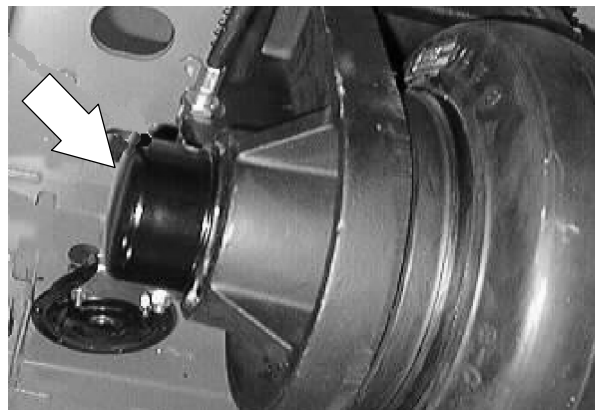

18. Locate the area where the brake cable attaches to the drive support. The beginning adjustment should be **1.375 in.** of conduit showing on the cable end.

19. Turn the steering wheel all the way to the right.

NOTE: Spin the tire/wheel assembly to make sure the brakes are not dragging with the brake pedal NOT engaged.

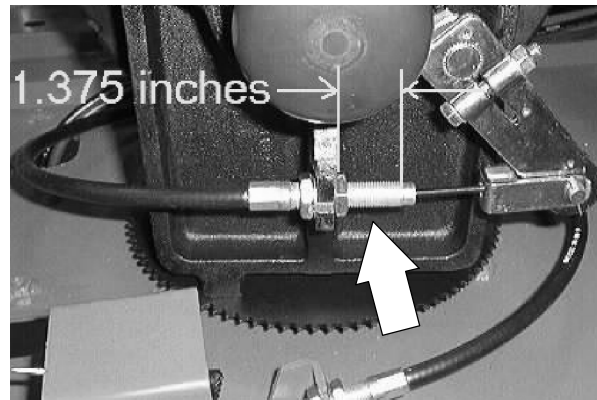

20. Go to the other side of the drive assembly and install the planetary gear box, outer plate, and motor assembly into the wheel assembly and onto the pins of the drive assembly.

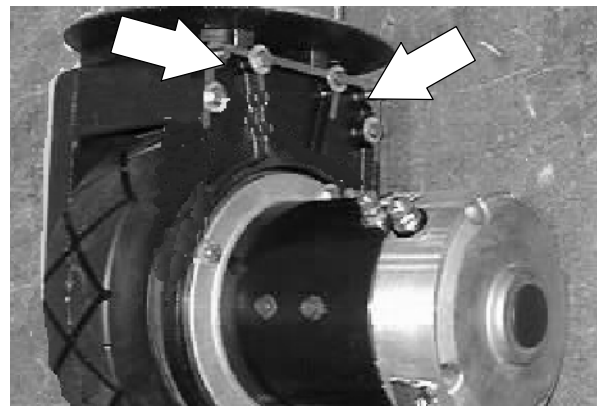

21. Install the 4 hex screws and washers. Tighten to 18 - 24 Nm (15 - 20 ft lb).

22. Reconnect the electrical cables to the drive motor.

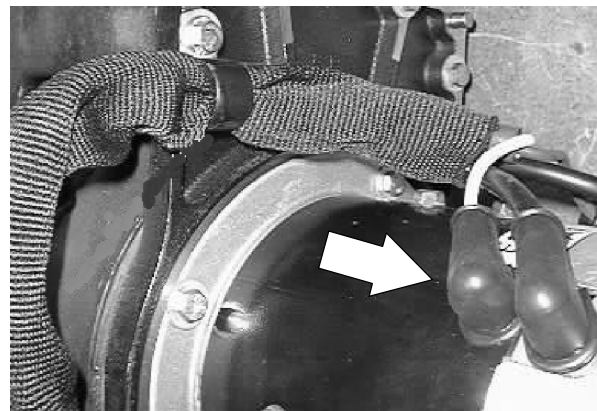

23. Remove the jack stands and lower the machine.

24. Reconnect the battery cables.



25. Drive the machine and check the brakes for proper operation. Adjust if necessary.

CHASSIS

REAR TIRES AND WHEELS

The rear tires on the model 6200E are semi-pneumatic. The rear tire and wheel assemblies are idler wheels only, they have no braking capabilities.

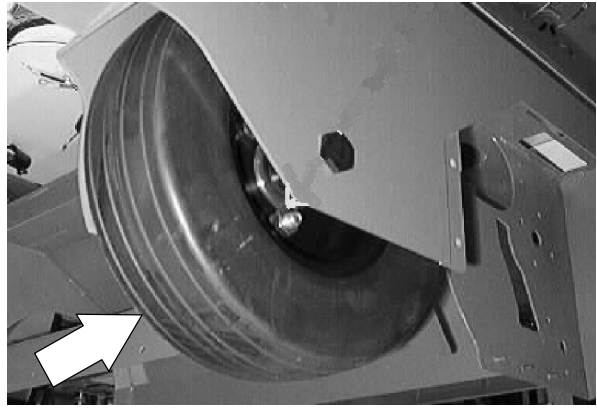

TO REMOVE REAR TIRE

FOR SAFETY: Before Leaving Or Servicing Machine; Stop On Level Surface, Set Parking Brake.

1. Jack up the rear corner of the machine where the tire needs to be removed.

NOTE: Do not raise both rear wheels off the floor at the same time. The machine will become unstable because of the single front tire.



2. Go under the machine in the area of the rear tire. Locate the lock nut holding the axle shaft to the machine frame. Remove the lock nut and washer.

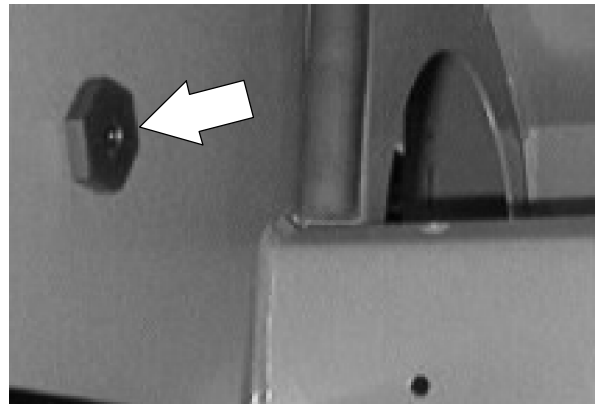

3. Support the tire while you pull the axle out of the wheel assembly. Drop the wheel assembly out of the machine.

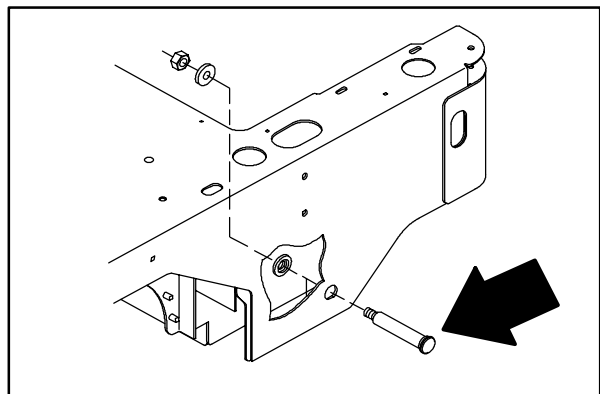

TO INSTALL REAR TIRE

FOR SAFETY: Before Leaving Or Servicing Machine; Stop On Level Surface, Set Parking Brake.

1. Position the wheel assembly in the machine. (short side of hub toward outside) Raise the tire up and align the hole in the wheel bearing with the axle hole in the frame.

NOTE: The lug nuts must face the outside of the machine.

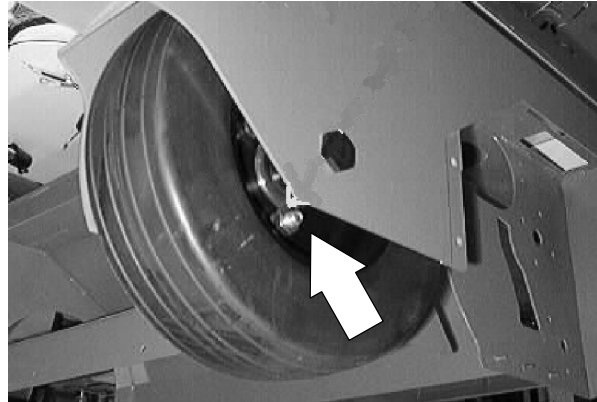

2. Install the axle shaft in the machine from the outside of the frame.

NOTE: The axle has a flat portion that must line up with the flat in the axle mount hole.

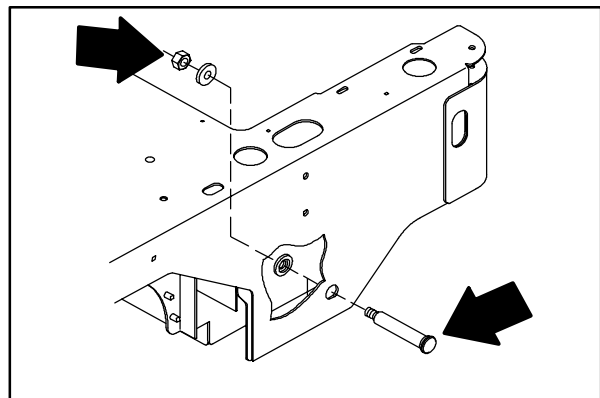

3. Install the washer and nut on the axle. Tighten to 68 - 81 Nm (50 - 60 ft lb).

4. Remove the jack stands and lower the machine.

5. Drive the machine and check for proper operation.

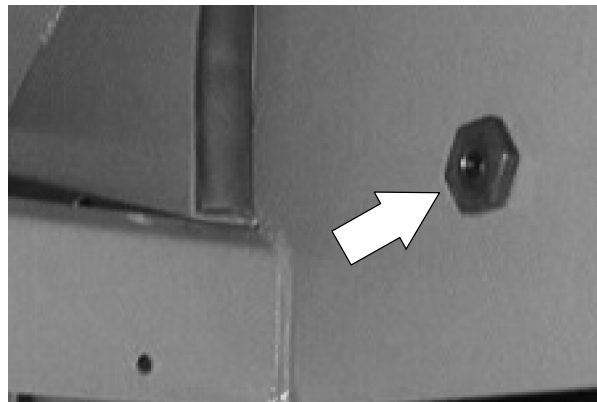

TO REPLACE REAR WHEEL BEARINGS

FOR SAFETY: Before Leaving Or Servicing Machine; Stop On Level Surface, Set Parking Brake.

1. Remove the rear wheel assembly. See TO REMOVE REAR TIRE instructions.
2. Remove the three lug nuts holding the bearing housing to the wheel assembly. Remove the bearing housing.

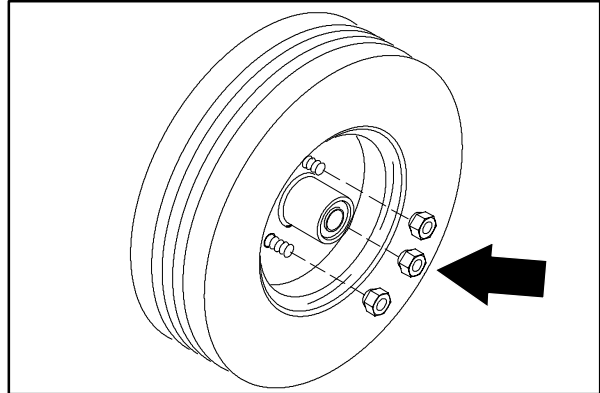

3. Use a press to remove the wheel bearings from the housing.

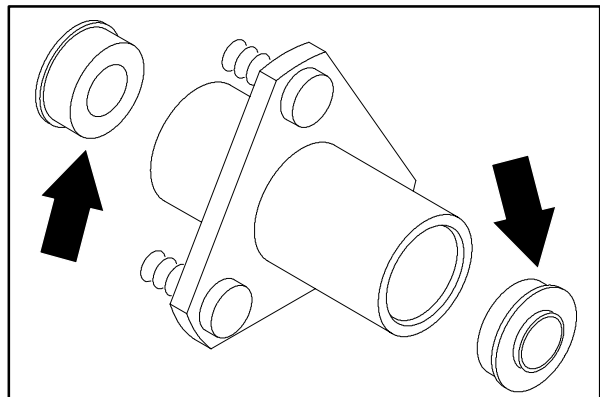

4. Press the new wheel bearings into the housing. Press the bearing in until the flange is seated on the housing.

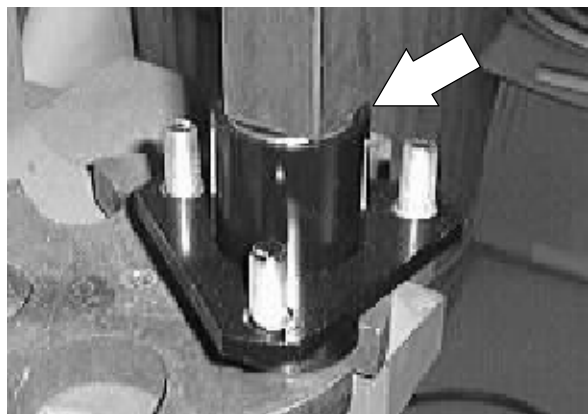

5. Reinstall the wheel on the bearing housing. (coining on wheel facing lug nuts) Tighten the three lug nuts to 58 - 76 Nm (43 - 56 ft lb).

NOTE: The lug nuts must face the outside of the machine.

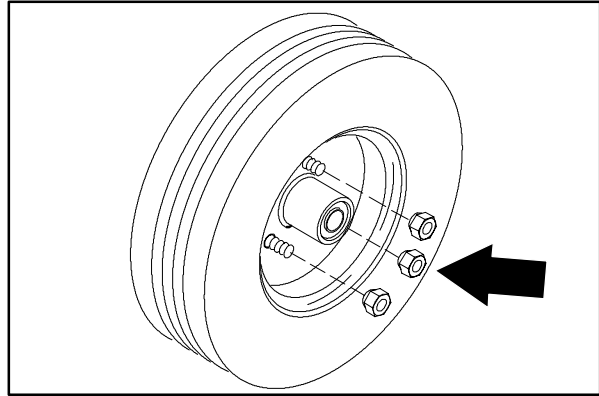

6. Reinstall the rear wheel assembly in the machine. See TO INSTALL REAR TIRE instructions.

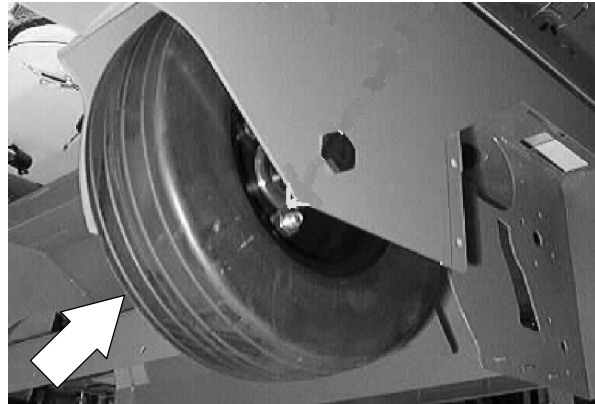

FRONT TIRE AND WHEEL, AND WHEEL DRIVE SUPPORT

The front drive assembly controls the forward and reverse movement of the machine along with the braking and steering. The brakes are actuated with a cable and uses a sprocket and chain assembly for the steering. Forward and reverse is accomplished with an electric motor and planetary gearbox.

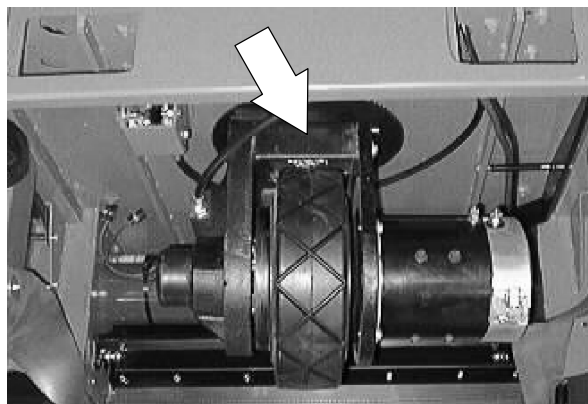

FRONT WHEEL SUPPORT CASTER BEARING ASSEMBLY

The front wheel support caster bearing is located between the bottom swivel plate and the upper swivel plate weldment. The bearing is a flat needle bearing style.

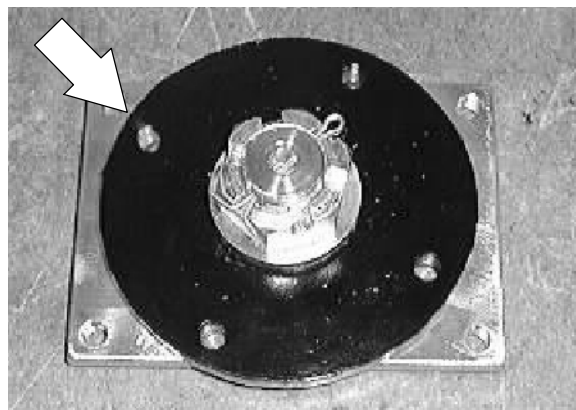

TO REMOVE FRONT DRIVE ASSEMBLY

FOR SAFETY: Before Leaving Or Servicing Machine; Stop On Level Surface, Set Parking Brake.

1. Raise the seat support and unplug the battery connectors.
2. Raise the front of the machine and place jack stands under the frame.

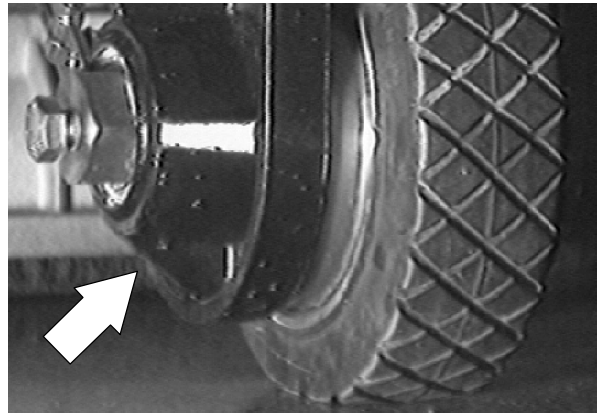

3. Mark and remove the electrical cables leading to the drive motor.



4. Go in operators compartment and loosen the lower steering shaft mount screws.

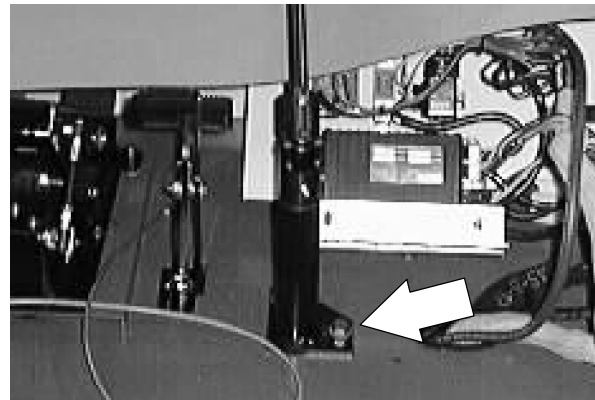

5. Pull the mount back to give the steering chain slack. Locate and remove the master link and steering chain.

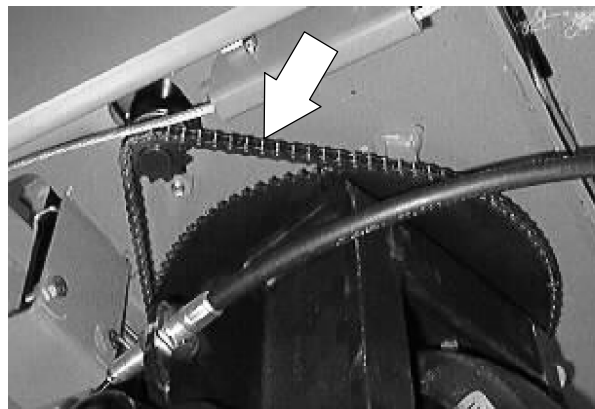

CHASSIS

6. Remove the cotter pin and clevis pin from the end of the brake cable where it attaches to the lever on the wheel support.

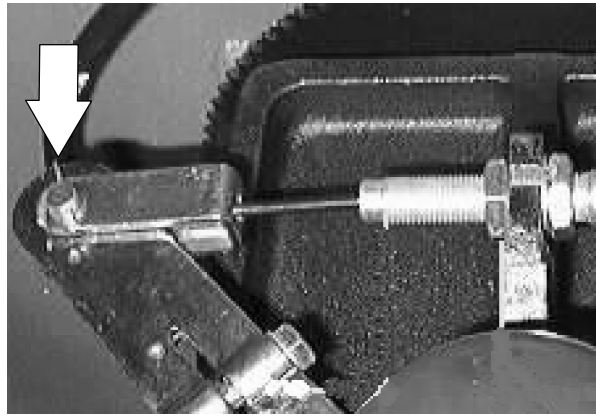

7. Loosen the jam nut on the brake cable where it attaches to the wheel support. Remove the brake cable from the wheel support.

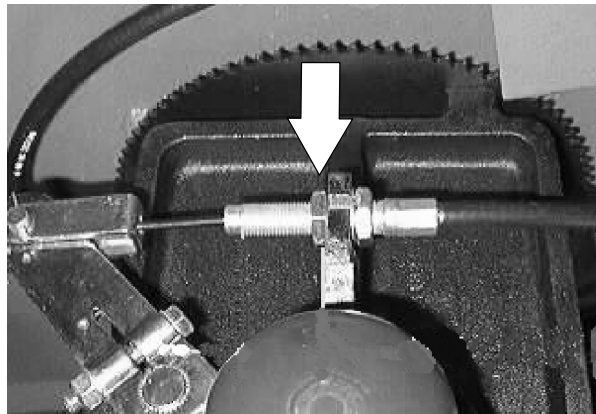

8. Position a floor jack or transmission jack under the drive wheel. This will support the drive assembly when the hardware is removed.

9. Go to the operators compartment and locate the 4 button head screws holding the drive assembly to the floor plate. Remove the 4 screws while supporting the drive assembly.

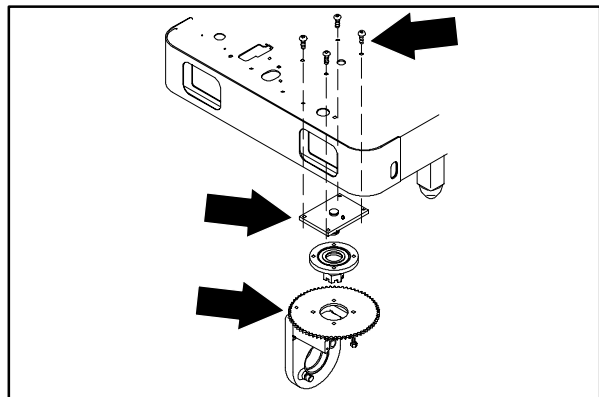

10. Remove the drive assembly from the machine.

TO INSTALL FRONT DRIVE ASSEMBLY

FOR SAFETY: Before Leaving Or Servicing Machine; Stop On Level Surface, Set Parking Brake.

1. Raise the seat support and unplug the battery connectors.
2. Raise the front of the machine and place jack stands under the frame.
3. Place the front drive assembly on a floor jack or transmission jack. This will support the drive assembly when installing it in the machine.
4. Position the drive assembly under the machine in front.
5. Raise the drive assembly up until the mount holes in the floor plate are aligned with the mount holes in the upper swivel plate weldment on top of the drive assembly.

NOTE: Make sure to position the grease zerk in the access hole in the machine floor plate.

6. Install the four button head screws and tighten to 64 - 83 Nm (47 - 61 ft lb).
7. Reinstall the steering chain and master link. Adjust the steering chain. See TO ADJUST STEERING CHAIN instructions.
8. Reinstall the brake cable on the wheel support. Tighten the jam nut on the brake cable where it attaches to the wheel support.

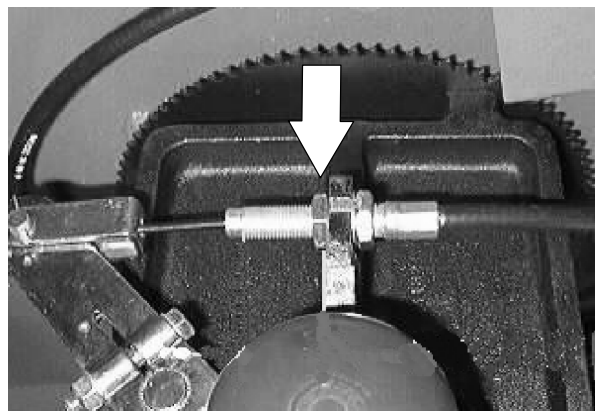
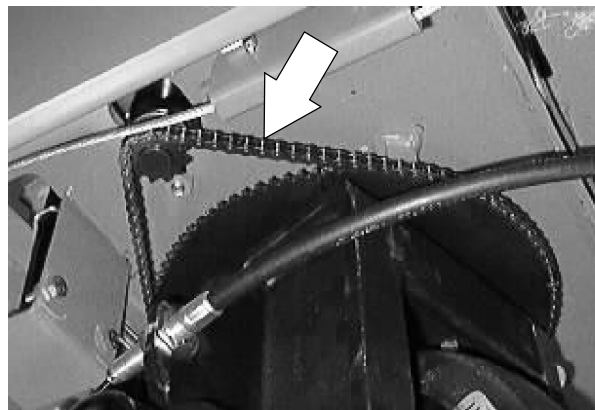
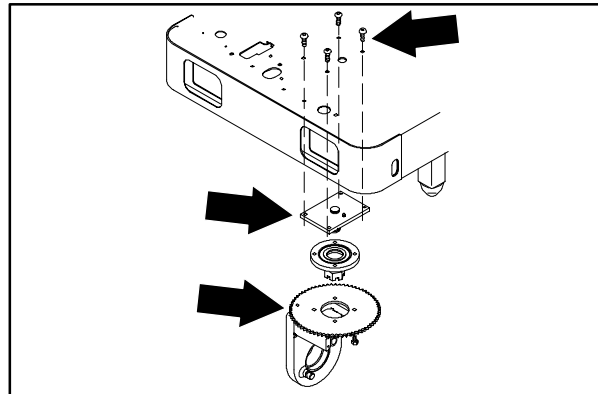
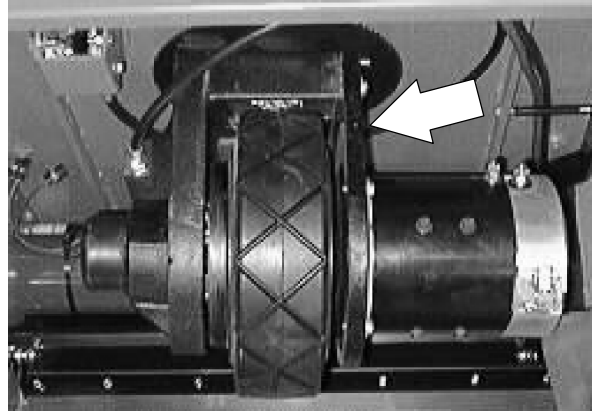

CHASSIS

9. Reinstall the cotter pin and clevis pin in the end of the brake cable where it attaches to the lever on the wheel support.

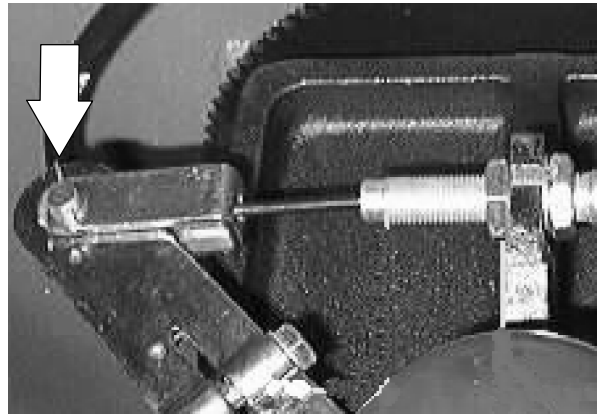

10. Turn the steering wheel all the way to the right.
11. Locate the area where the brake cable attaches to the drive support. The beginning adjustment should be **1.375 in.** of conduit showing on the cable end.

Note: Spin the tire/wheel assembly to make sure the brakes are not dragging with the brake pedal NOT engaged.

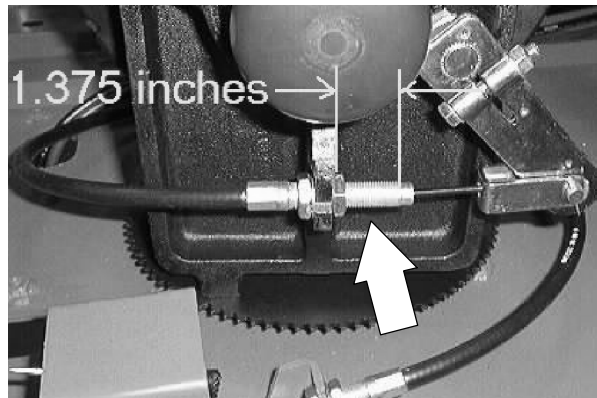

12. Reinstall the electrical cables on the drive motor.
13. Remove the jack stands and lower the machine.

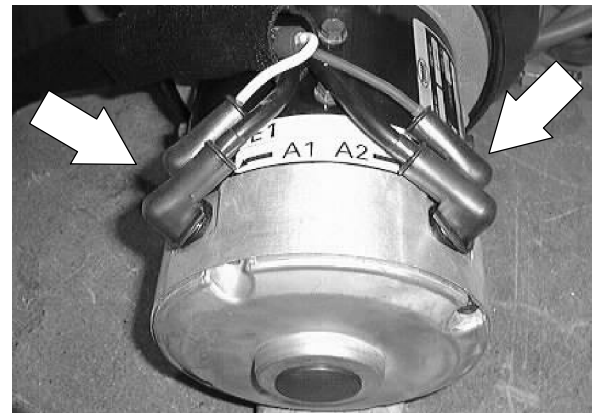

14. Reconnect the battery cables.
15. Operate the machine and check for proper operation. Check the brakes for proper operation. Adjust if necessary. See TO ADJUST SERVICE BRAKES instructions.

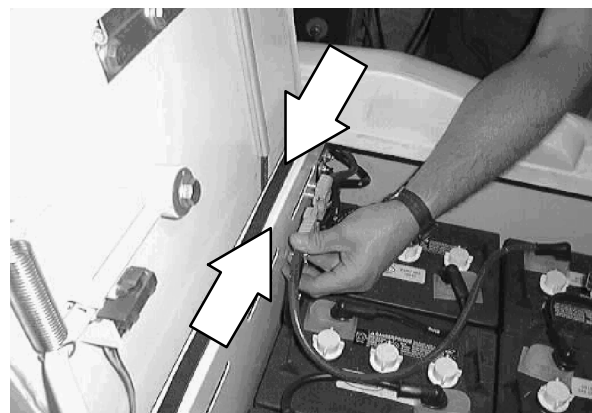

TO REPLACE DRIVE ASSEMBLY CASTER BEARING AND THRUST WASHERS

FOR SAFETY: Before Leaving Or Servicing Machine; Stop On Level Surface, Set Parking Brake.

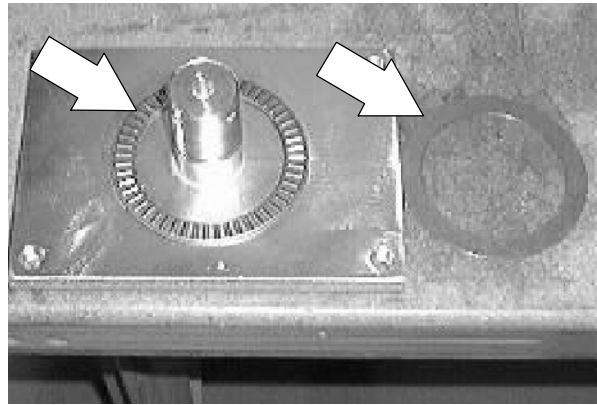

1. Remove the drive assembly from the machine. See TO REMOVE FRONT DRIVE ASSEMBLY instructions.

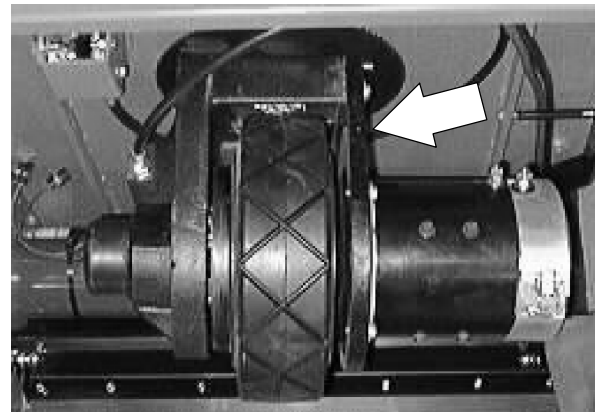

2. Remove the four hex screws holding the outer plate, motor, and planetary gear box to the main drive assembly.

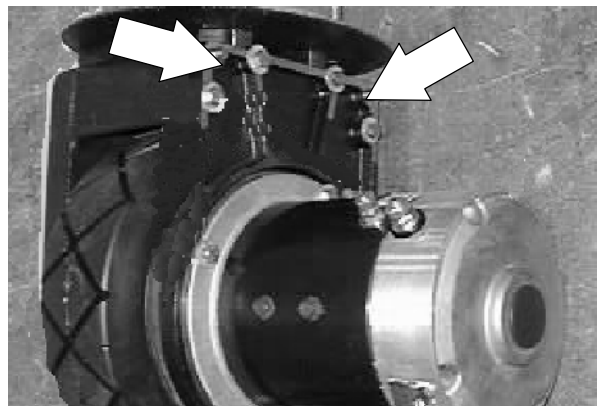

3. Pull the planetary gear box, outer plate, and motor out of the drive wheel and away from the drive assembly.

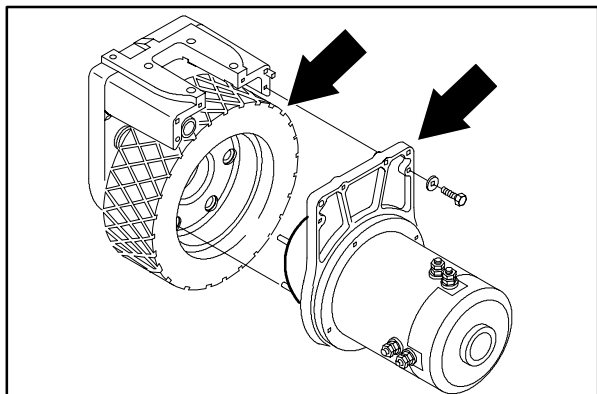

CHASSIS

4. Remove the four hex screws holding the pivot and sprocket assembly to the drive assembly.

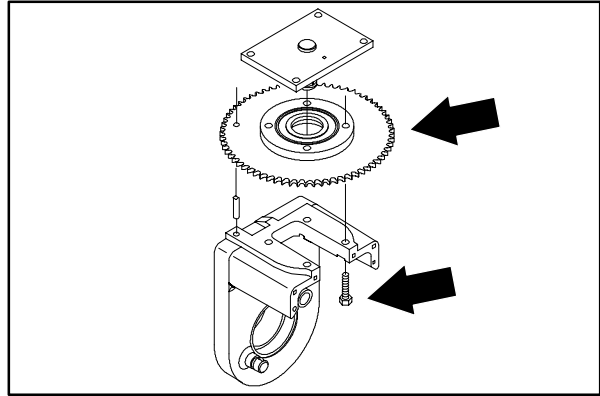

5. Remove the sprocket from the pivot assembly.

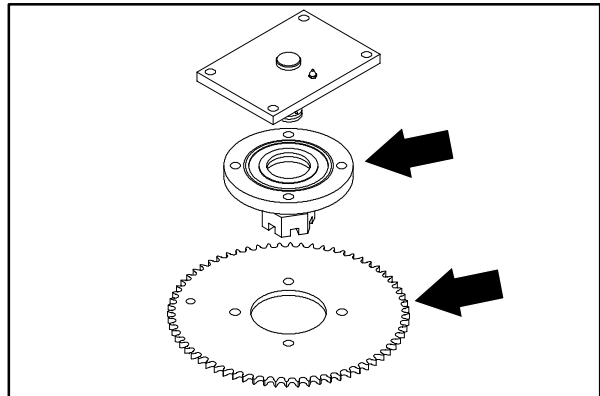

6. Remove the cotter pin and castle nut from the upper swivel plate weldment.

7. Remove the flat washer and cone bearing from the bottom swivel plate.

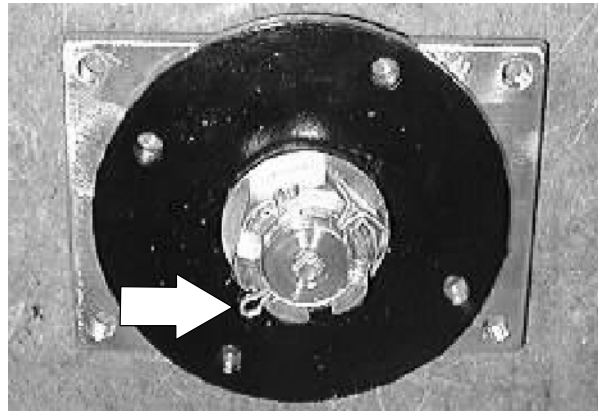

8. Lift the bottom swivel plate off the upper swivel plate weldment.

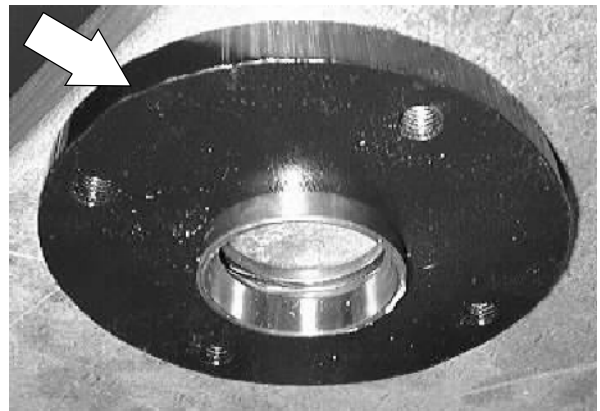

9. Remove and discard both thrust washers and the caster bearing from the upper swivel plate weldment.

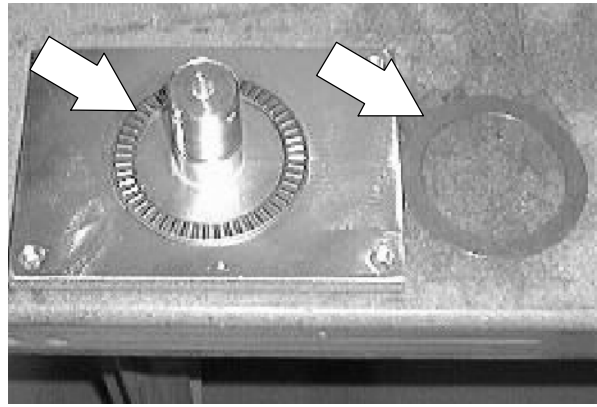

10. Apply grease on both sides of the new caster bearing.
11. Position the new caster bearing on top of the new lower thrust washer.
12. Reinstall the second new thrust washer on top of the new caster bearing.

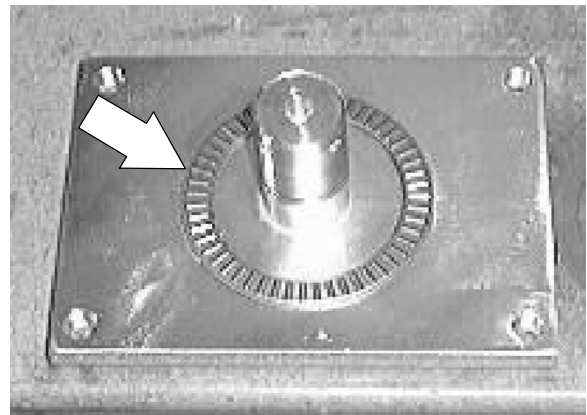

13. Reinstall the bottom swivel plate on the upper swivel plate weldment. Make sure the grease seal is in place on the upper swivel plate weldment.

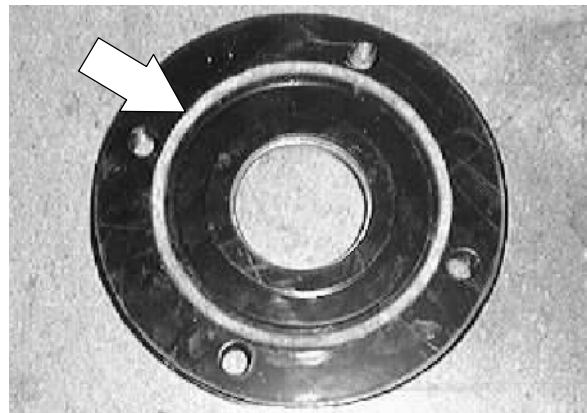

14. Reinstall the bearing cone and flat washer on the bottom swivel plate. Make sure the bearing cone is greased.

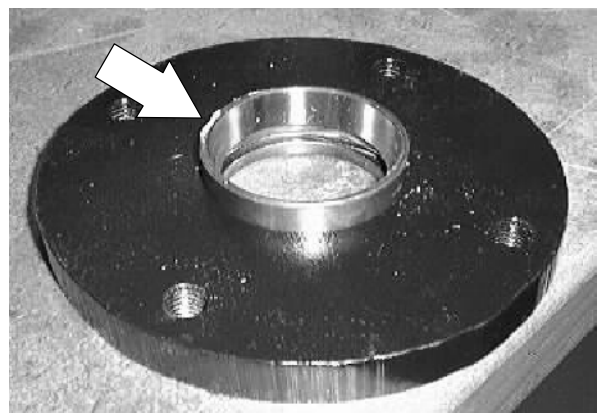

CHASSIS

15. Reinstall the castle nut and tighten to (125 ft lbs). Then back off to the next nearest hole and install the cotter pin. Check to make sure the caster bearing can be turned by hand. Reduce torque if necessary.

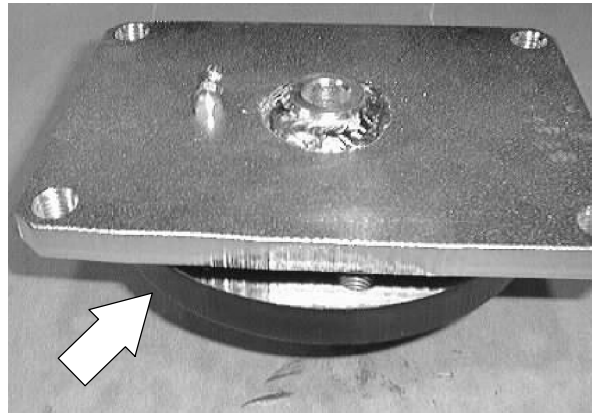

16. Reinstall the sprocket on the front drive assembly.
17. Reinstall the pivot and sprocket assembly on the drive assembly. Reinstall the four screws and tighten to 68 - 81 Nm (50 - 60 ft lb).

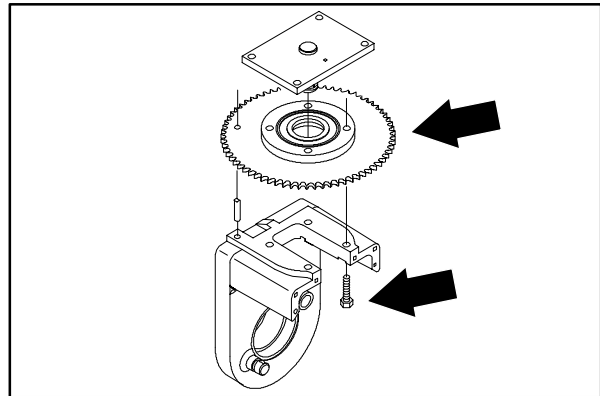

18. Install the planetary gear box, outer plate, and motor assembly into the wheel assembly and onto the pins of the drive assembly.

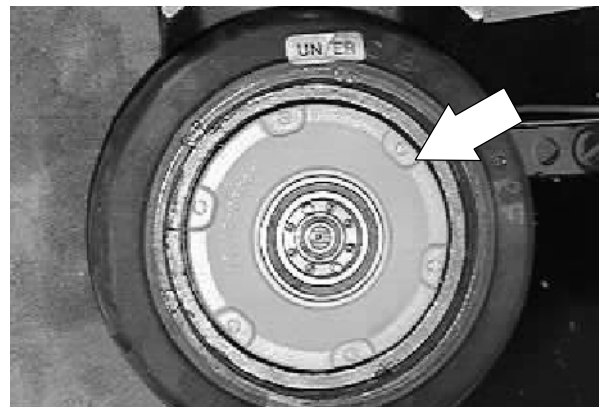

19. Install the 4 hex screws and washers. Tighten to 18 - 24 Nm (15 - 20 ft lb).

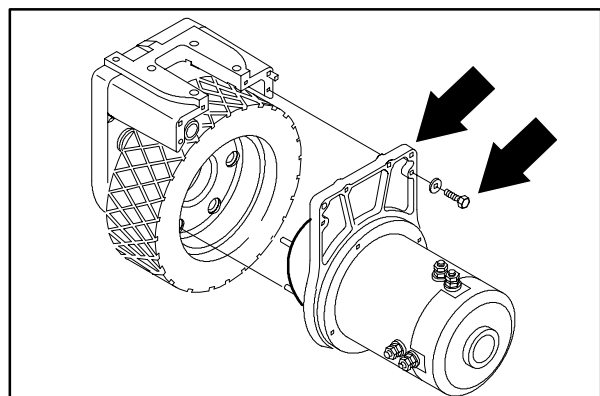

20. Reinstall the drive assembly in the machine.
See TO INSTALL FRONT DRIVE ASSEMBLY instructions.

21. Operate the machine and check for smooth steering operation. Check the brakes for proper operation. Adjust if necessary. See TO ADJUST SERVICE BRAKES instructions.

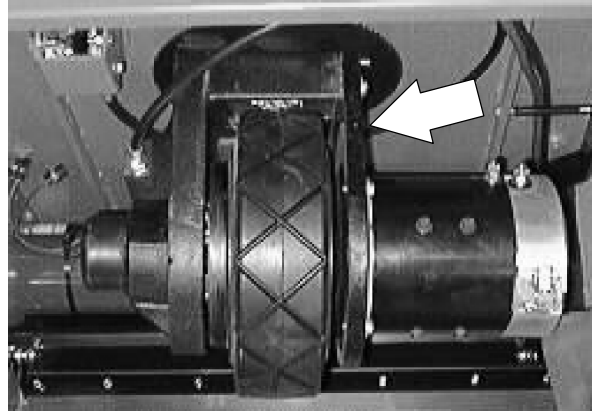

CHASSIS

TO REPLACE DRIVE ASSEMBLY PIVOT CONE BEARING

FOR SAFETY: Before Leaving Or Servicing Machine; Stop On Level Surface, Set Parking Brake.

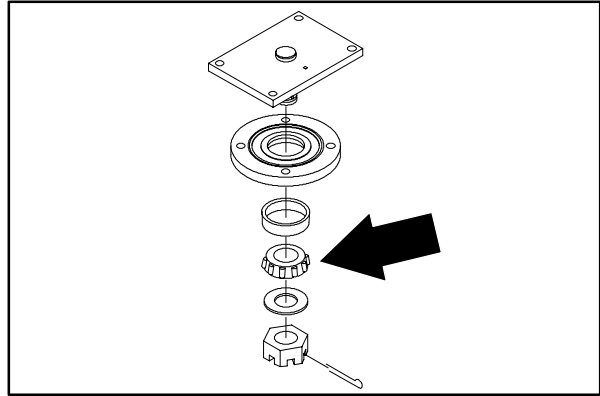

1. Remove the drive assembly from the machine. See TO REMOVE FRONT DRIVE ASSEMBLY instructions.

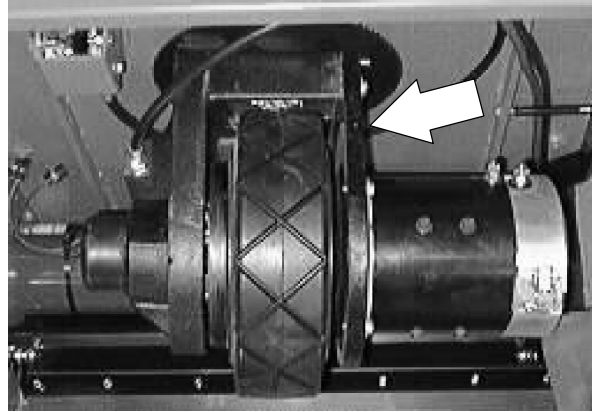

2. Remove the four hex screws holding the outer plate, motor, and planetary gear box to the main drive assembly.

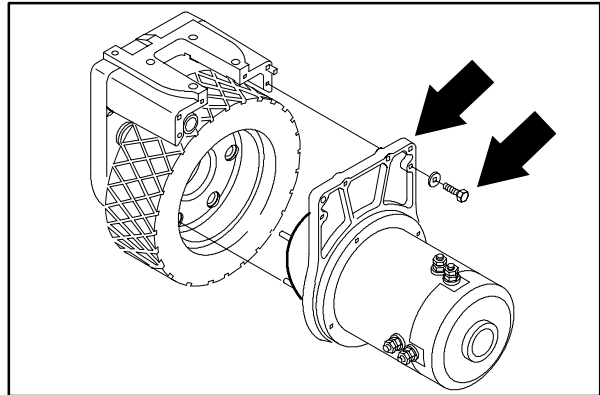

3. Pull the planetary gear box, outer plate, and motor out of the drive wheel and away from the drive assembly.

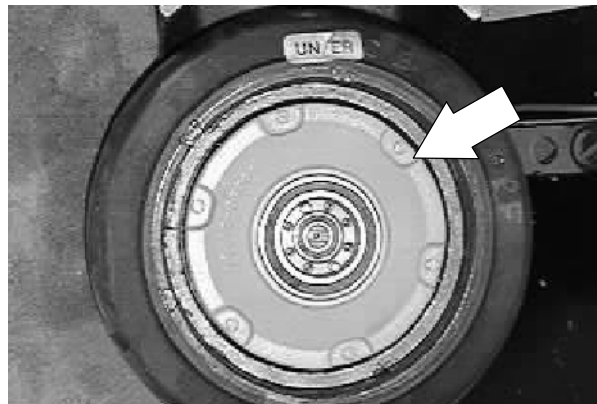

4. Remove the four hex screws holding the pivot and sprocket assembly to the drive assembly.
5. Remove the sprocket from the pivot assembly.

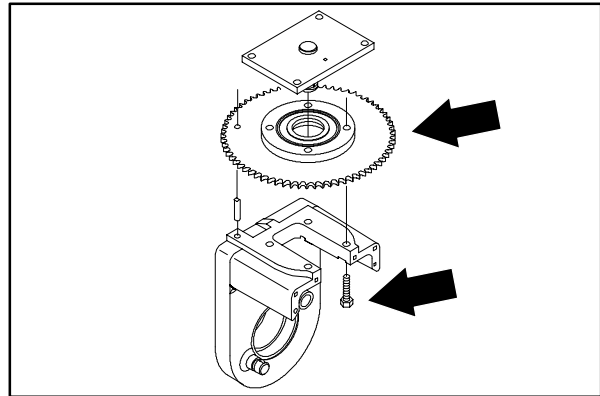

6. Remove the cotter pin and castle nut from the upper swivel plate weldment.

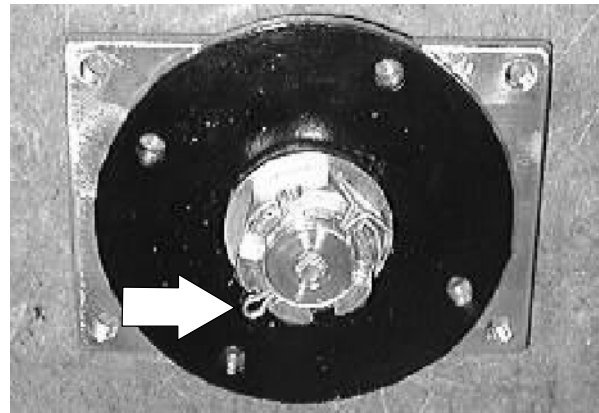

7. Remove the flat washer and old cone bearing from the bottom swivel plate.
8. Install the new cone bearing and flat washer on the bottom swivel plate. Make sure the new cone bearing is greased.
9. Reinstall the castle nut and tighten to 200 Nm (150 ft lbs). Then tighten to the next nearest hole and install the cotter pin.

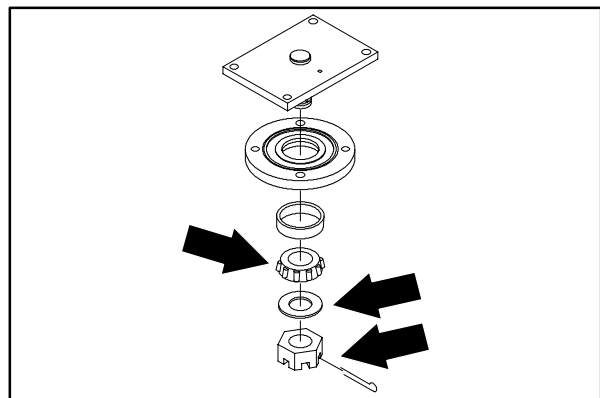

10. Reinstall the sprocket on the pivot assembly.

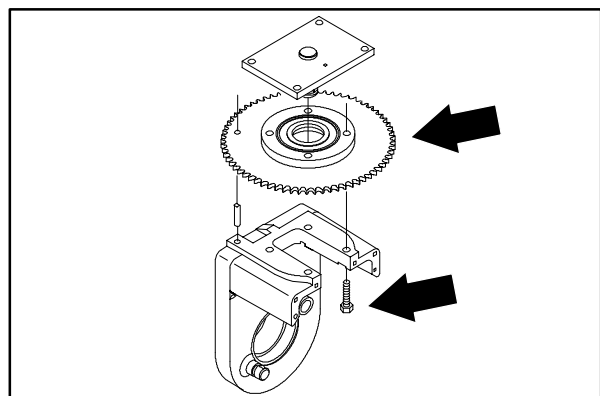

CHASSIS

11. Reinstall the pivot and sprocket assembly on the drive assembly. Reinstall the four screws and tighten to 68 - 81 Nm (50 - 60 ft lb).

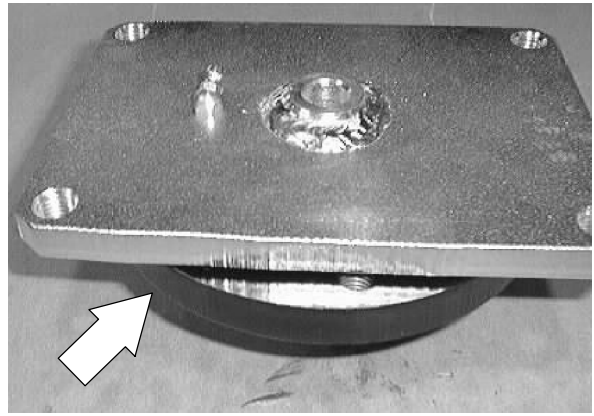

12. Install the planetary gear box, outer plate, and motor assembly into the wheel assembly and onto the pins of the drive assembly.

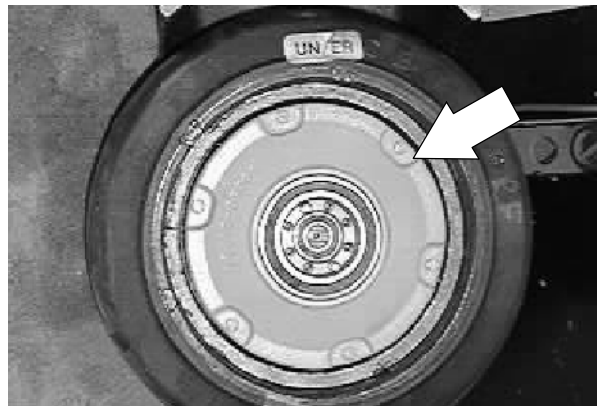

13. Install the 4 hex screws and washers. Tighten to 18 - 24 Nm (15 - 20 ft lb).

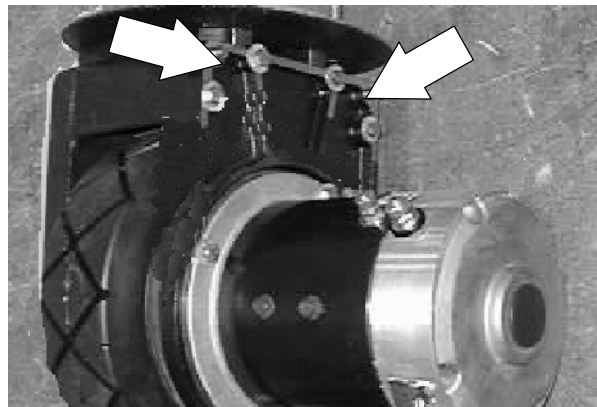

14. Reinstall the drive assembly in the machine. See TO INSTALL FRONT DRIVE ASSEMBLY instructions.

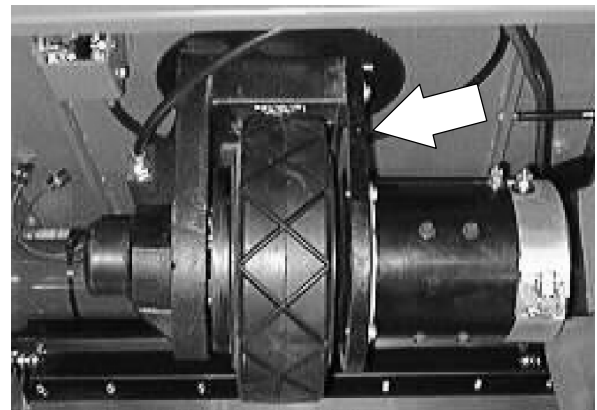

15. Operate the machine and check for smooth steering operation. Check the brakes for proper operation. Adjust if necessary. See TO ADJUST SERVICE BRAKES instructions.

PLANETARY GEAR BOX

The model 6200E front drive system includes a self contained planetary gearbox. The electric drive motor provides power to the planetary gearbox which, through a gear reduction, spins the front tire.

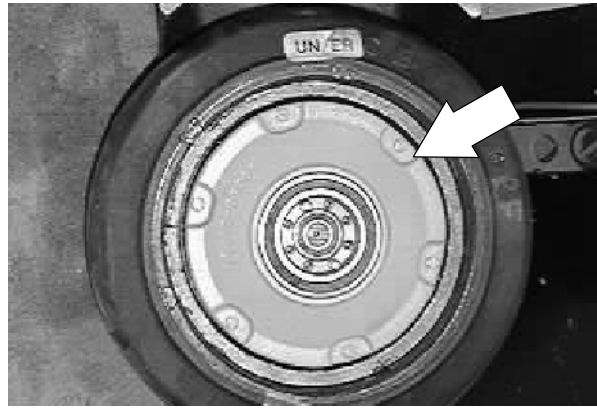

TO REMOVE PLANETARY GEAR BOX

FOR SAFETY: Before Leaving Or Servicing Machine; Stop On Level Surface, Set Parking Brake.

1. Raise the seat support and unplug the battery connectors.
2. Raise the front of the machine and place jack stands under the frame.
3. Mark and remove the electrical cables leading to the drive motor.

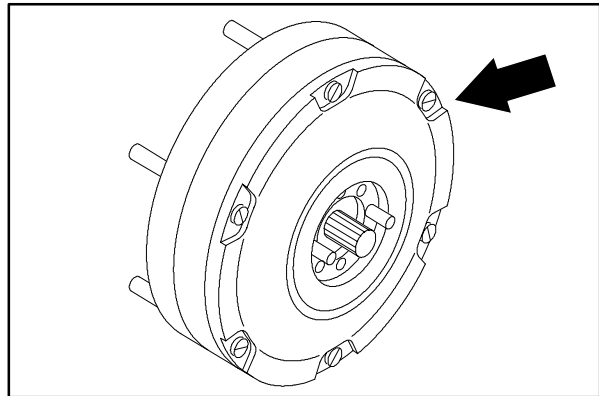

4. Remove the 4 hex screws holding the electric drive motor to the drive assembly outer plate. Remove the drive motor.

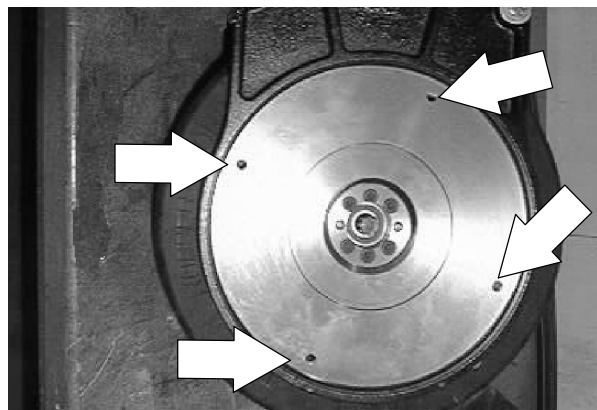

CHASSIS

5. Remove the four hex screws holding the outer plate to the main drive assembly.

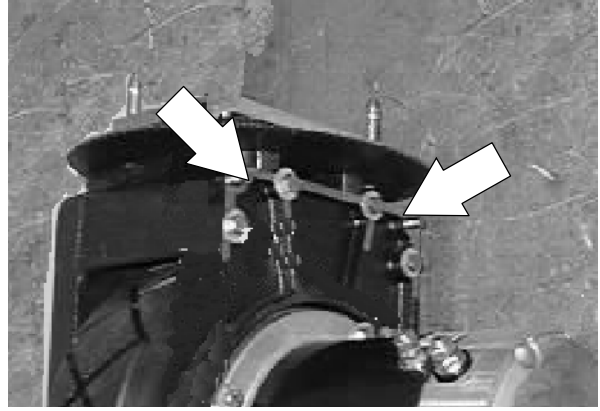

6. Remove the 6 socket screws holding the outer plate to the planetary gear box. Remove the outer plate.

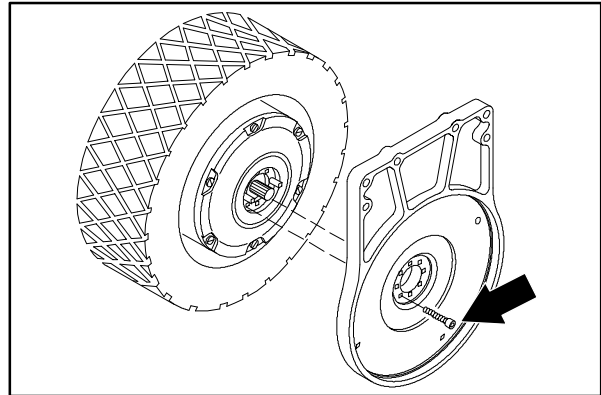

7. Pull the old planetary gear box out of the drive wheel. Remove the old planetary gear box from the machine.

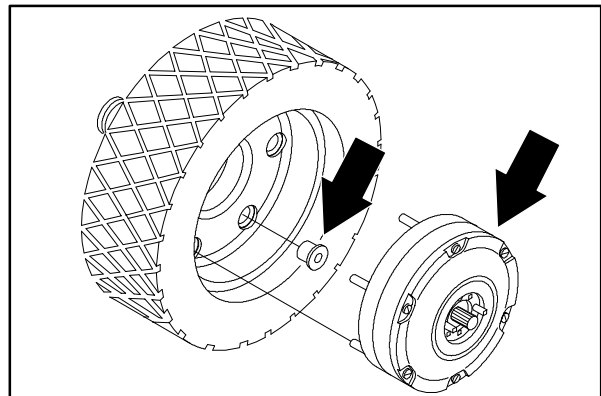

TO INSTALL PLANETARY GEAR BOX

FOR SAFETY: Before Leaving Or Servicing Machine; Stop On Level Surface, Set Parking Brake.

1. Install the new planetary gearbox on the outer motor mount plate. Install the 6 socket screws into the planetary gear box. Torque the 6 screws to 193 Ncm – 250 Ncm.

NOTE: Do not tighten this hardware above a grade 2 torque. The planetary gearbox is made from a softer grade of cast iron and the threads could strip out.

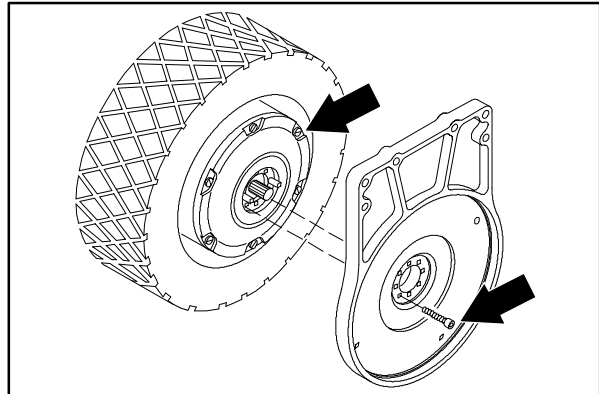

2. Reinstall the outer motor mount plate and gear box on the drive assembly. Tighten the four screws to 18 – 24 Nm (15 – 20 ft lb).

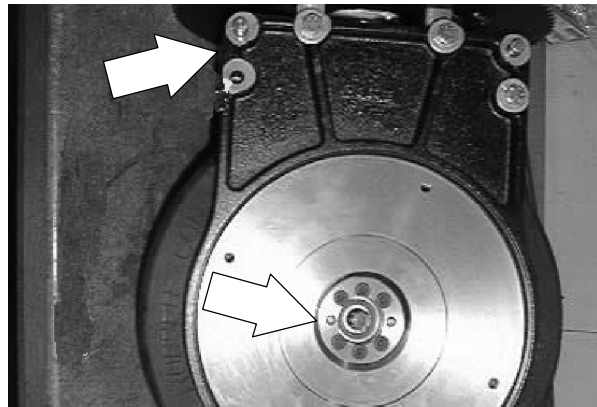

NOTE: When installing the motor on the drive assembly, make sure the terminals are pointing up and slightly forward for proper electrical cable installation.

3. Reinstall the electric motor on the drive assembly. Make sure to line up the splines on the motor shaft with the splines of the planetary gear box. Tighten the 4 hex screws to 18 – 24 Nm (15 – 20 ft lb).

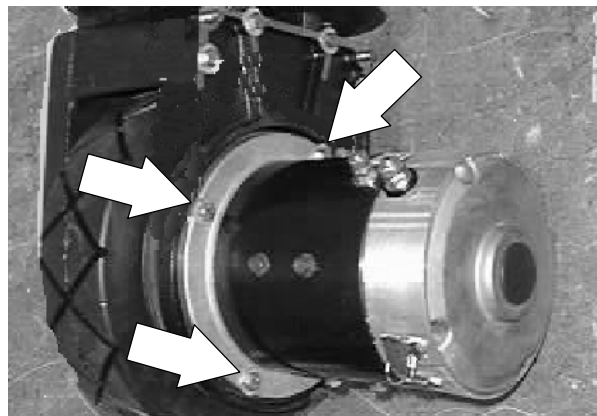

CHASSIS

4. Reconnect the electrical cables to the drive motor.

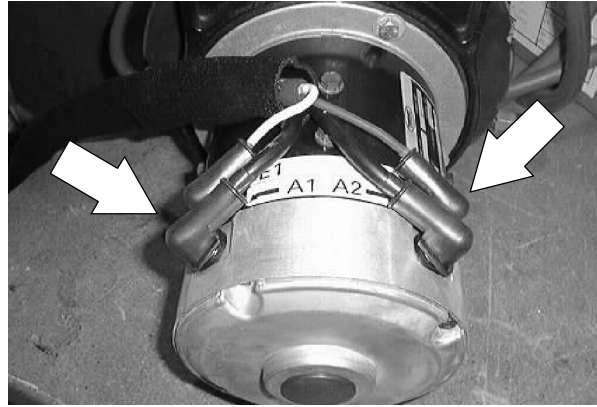

5. Remove the jack stands and lower the machine.

6. Reconnect the battery cables.

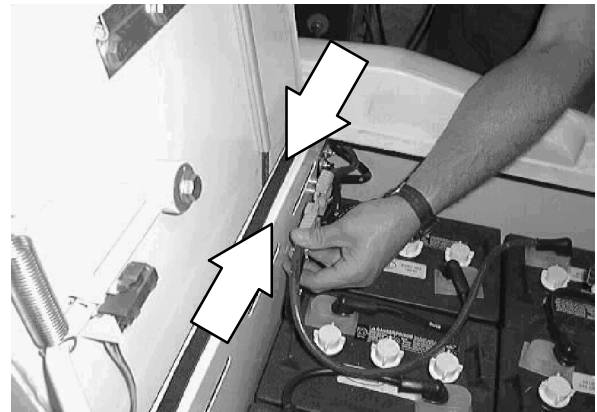

7. Operate the machine and check the new gearbox for proper operation.

TO REPLACE FRONT TIRE AND WHEEL ASSEMBLY

FOR SAFETY: Before Leaving Or Servicing Machine; Stop On Level Surface, Set Parking Brake.

1. Raise the seat support and unplug the battery connectors.
2. Raise the front of the machine and place jack stands under the frame.

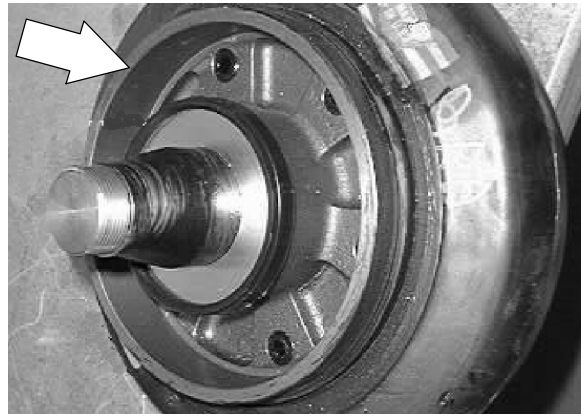

3. Mark and remove the electrical cables leading to the drive motor.

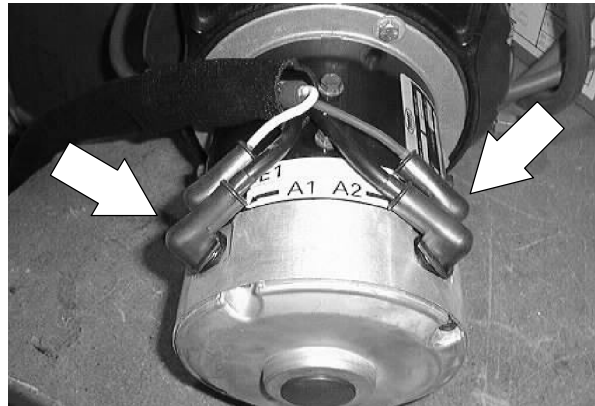

4. Remove the four hex screws holding the outer plate, motor, and planetary gear box to the main drive assembly.

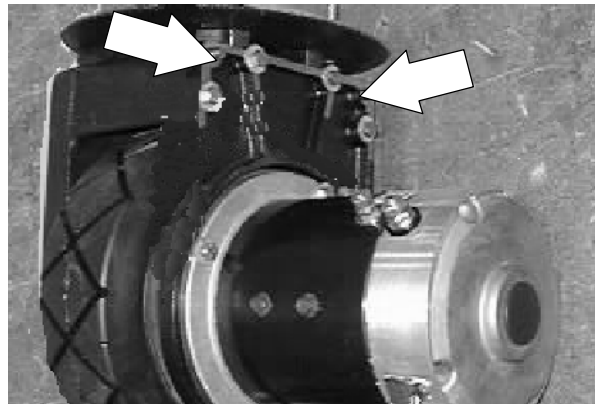

5. Pull the planetary gear box, outer plate, and motor out of the drive wheel and away from the drive assembly.

6. Go to the other side of the drive assembly and remove the hub cap. This will expose the outer bearing, hex sleeve, and lock bolt.

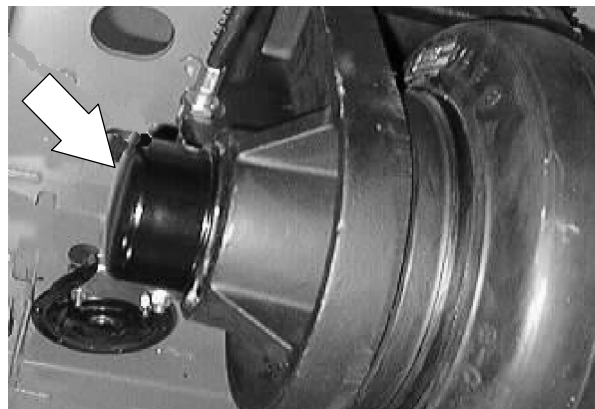

CHASSIS

- Remove the lock bolt.
(this is a right-hand thread screw).
- Remove the hex sleeve and outer bearing cone assembly.
(this is a left hand thread nut).

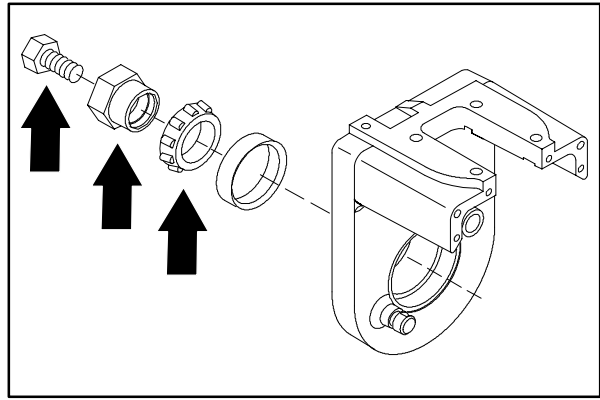

- The inner bearing, axle shaft, and tire/wheel assembly can now be removed from the drive assembly. Use a press to remove the inner bearing from the existing tire/wheel assembly.

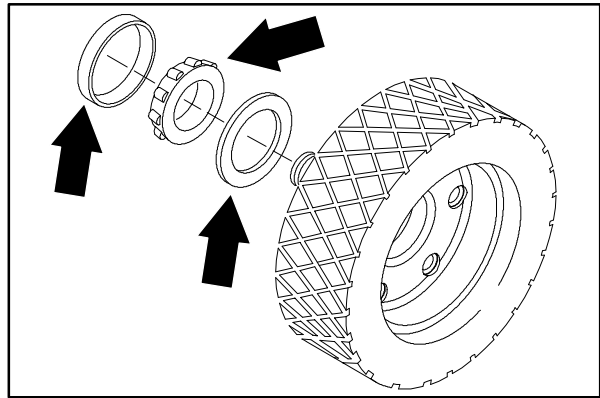

- Install the inner bearing on the new tire/wheel assembly.

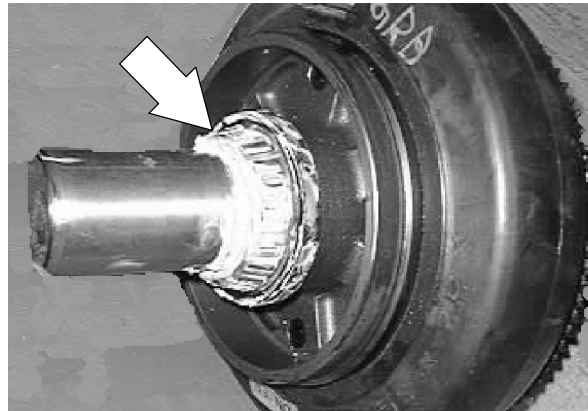

- Reinstall the new tire/wheel assembly in the drive assembly. Make sure the inner and outer wheel bearings are completely greased when re-assembling.

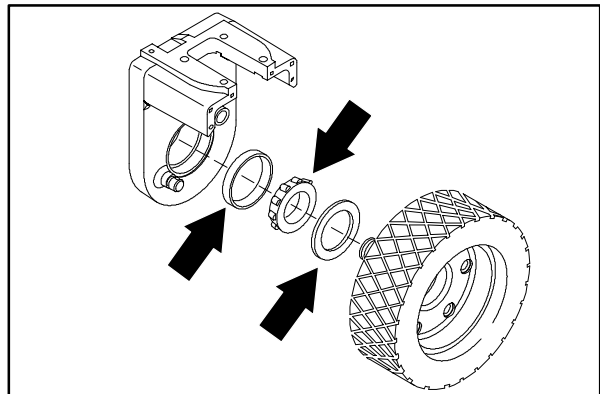

12. Reinstall the outer bearing and hex sleeve assembly. **(this is a left hand thread nut)** Tighten to at least 100 ft lbs and then back off the hex sleeve to 0 ft lbs. Re-torque hex sleeve to 30 ft lbs.

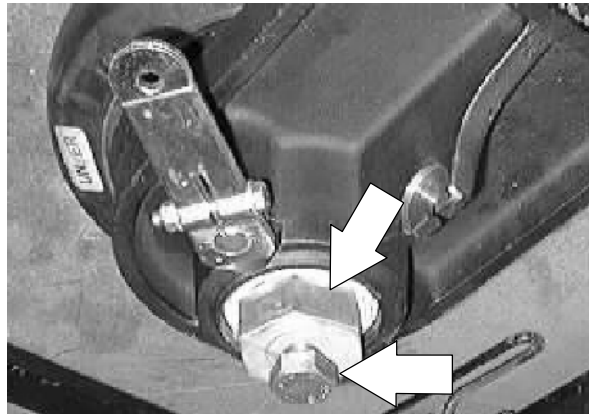

13. Install the lock bolt in the end of the hex sleeve. Tighten the lock bolt to 200 Nm (150 ft lb) while holding the hex sleeve from turning.

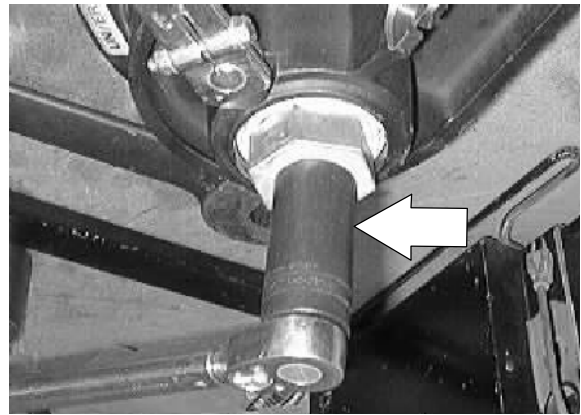

14. Reinstall the hub cap in the drive assembly.

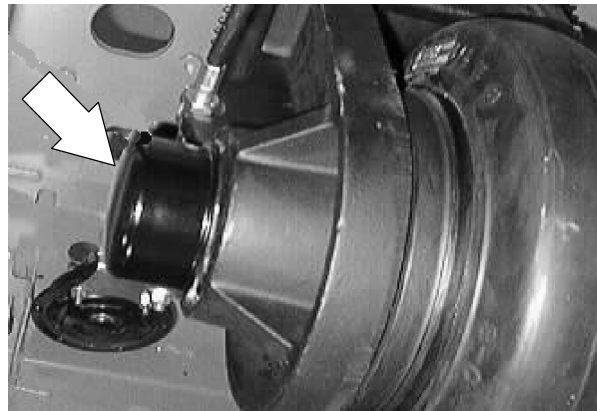

15. Go to the other side of the drive assembly. Install the planetary gear box, outer plate, and motor assembly into the wheel assembly and onto the pins of the drive assembly.

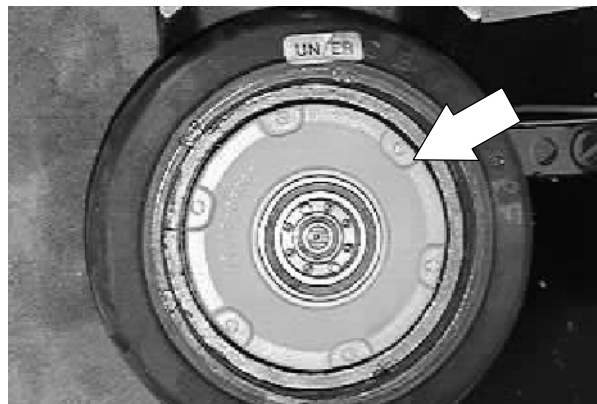

CHASSIS

16. Install the 4 hex screws and washers.
Tighten to 18 - 24 Nm (15 - 20 ft lb).

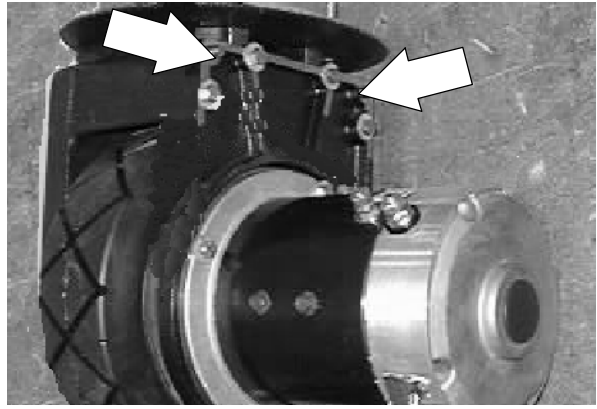

17. Reconnect the electrical cables to the drive motor.

18. Remove the jack stands and lower the machine.

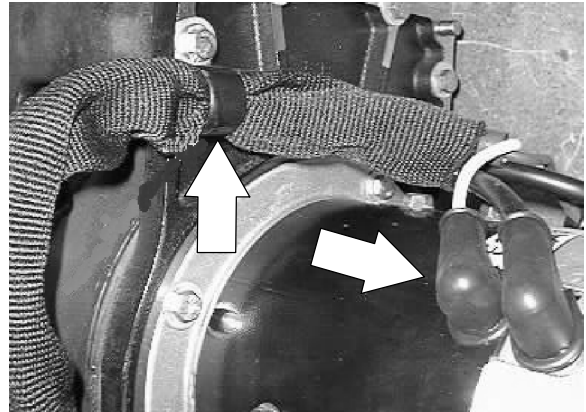

19. Reconnect the battery cables.

20. Drive the machine and check for proper operation.

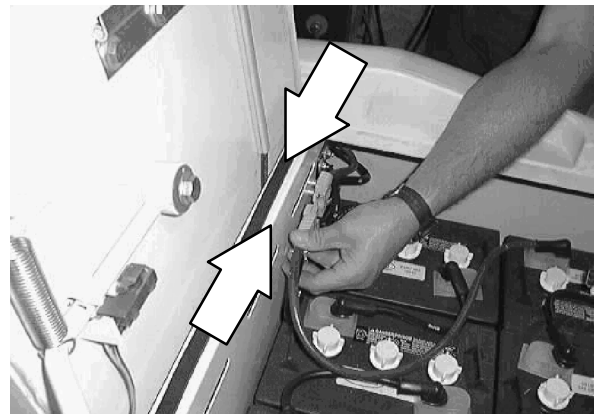

**TO REPLACE FRONT DRIVE ASSEMBLY
OUTER WHEEL BEARING**

FOR SAFETY: Before Leaving Or Servicing Machine; Stop On Level Surface, Set Parking Brake.

1. Raise the seat support and unplug the battery connectors.
2. Raise the front of the machine and place jack stands under the frame.
3. Go to the side of the drive assembly opposite the drive motor and remove the hub cap. This will expose the outer bearing, hex sleeve, and lock bolt.

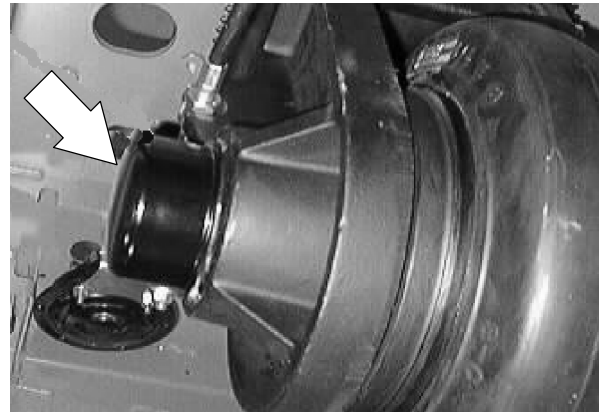
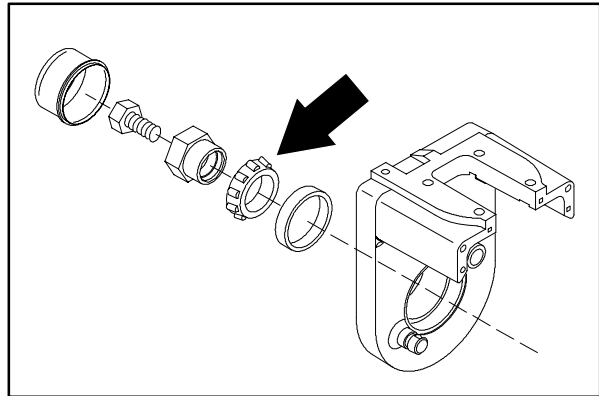

4. Remove the lock bolt.
(this is a right-hand thread screw).
5. Remove the hex sleeve and outer bearing cone assembly.
(this is a left hand thread nut).

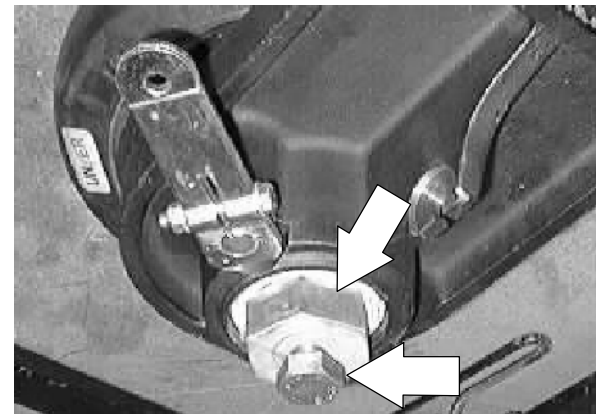

6. Use a press to remove the old outer bearing cone from the hex sleeve. Install a new outer bearing on the hex sleeve or replace the bearing and sleeve assembly. Apply grease to the new bearing.

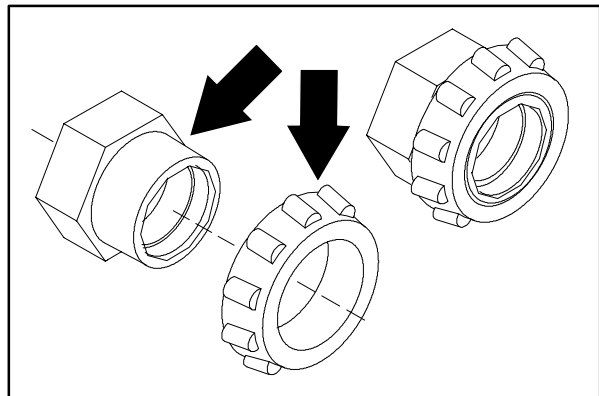

CHASSIS

7. Install the new outer bearing and hex sleeve assembly on the wheel shaft. **(this is a left hand thread nut)**. Tighten to at least 100 ft lbs and then back off the hex sleeve to 0 ft lbs. Re-torque hex sleeve to 30 ft lbs.

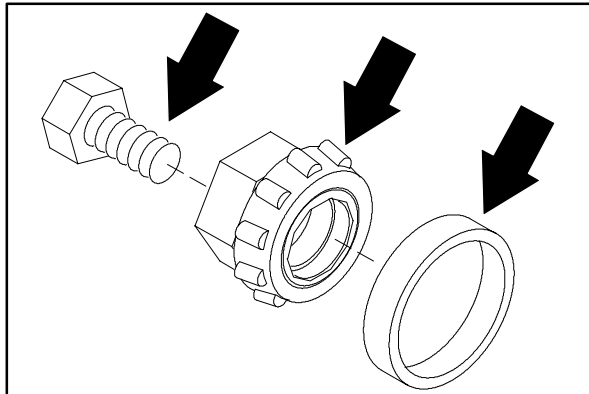

8. Install the lock bolt **(this is a right-hand thread screw)** in the end of the hex sleeve. Tighten the lock bolt to 200 Nm (150 ft lb) while holding the hex sleeve from turning.

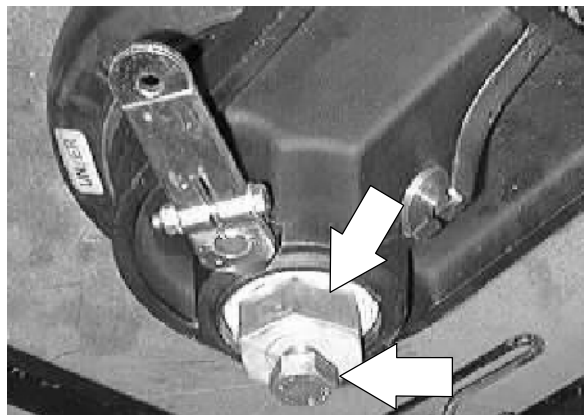

9. Reinstall the hub cap in the drive assembly.

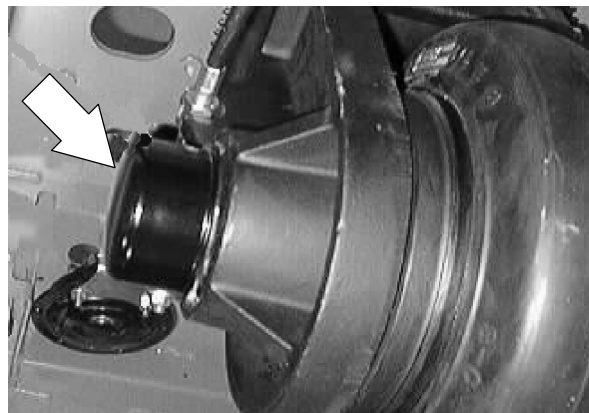

10. Remove the jack stands and lower the machine.

11. Reconnect the battery cables.

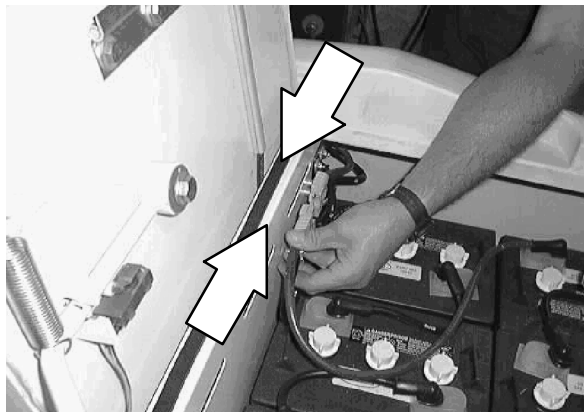

12. Drive the machine and check for proper operation.

TO REPLACE FRONT DRIVE ASSEMBLY INNER WHEEL BEARING

FOR SAFETY: Before Leaving Or Servicing Machine; Stop On Level Surface, Set Parking Brake.

1. Raise the seat support and unplug the battery connectors.
2. Raise the front of the machine and place jack stands under the frame.

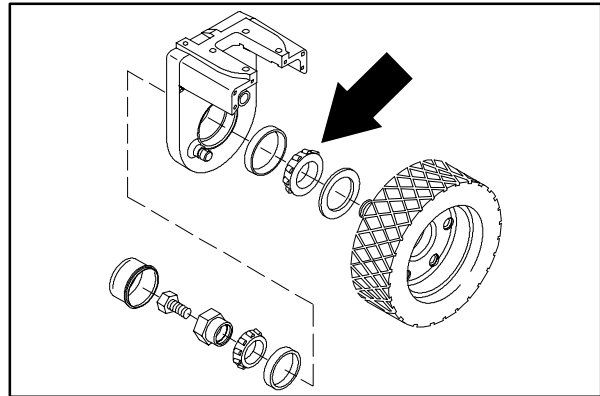

3. Mark and remove the electrical cables leading to the drive motor.

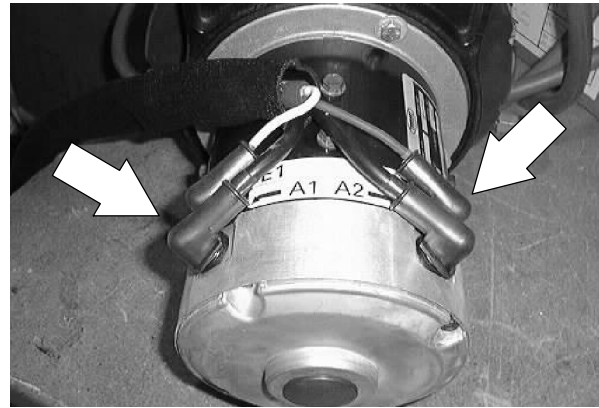

4. Remove the four hex screws holding the outer plate, motor, and planetary gear box to the main drive assembly.

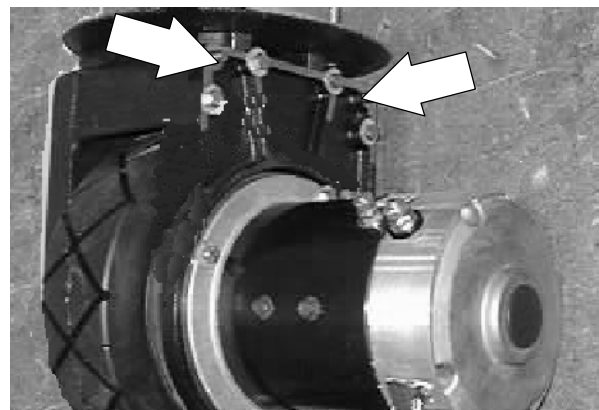

5. Pull the planetary gear box, outer plate, and motor out of the drive wheel and away from the drive assembly.

6. Go to the other side of the drive assembly and remove the hub cap. This will expose the outer bearing, hex sleeve, and lock bolt.

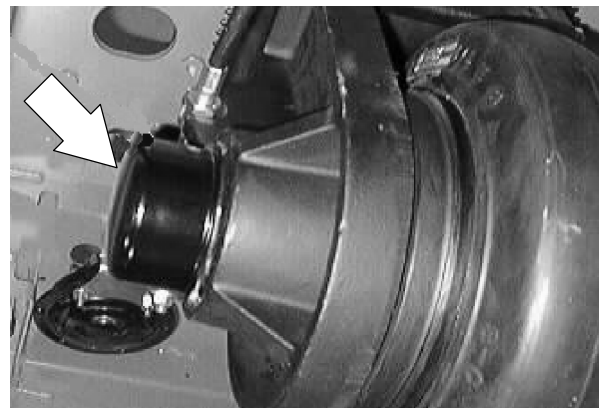

CHASSIS

7. Remove the lock bolt.
(this is a right-hand thread screw).
8. Remove the hex sleeve and outer bearing cone assembly.
(this is a left hand thread nut).

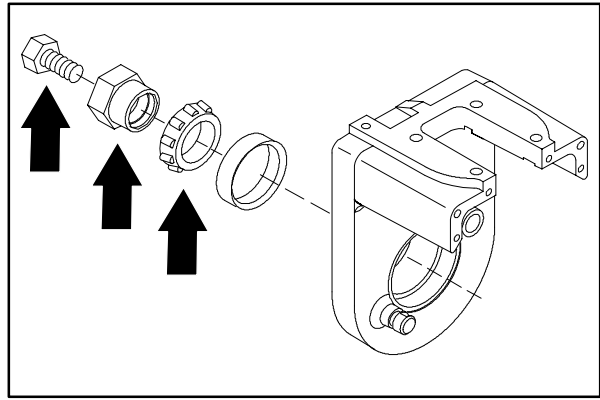

9. The inner bearing, axle shaft, and tire/wheel assembly can now be removed from the drive assembly. Use a press to remove the inner bearing from the existing tire/wheel assembly. Discard the old wheel bearing.

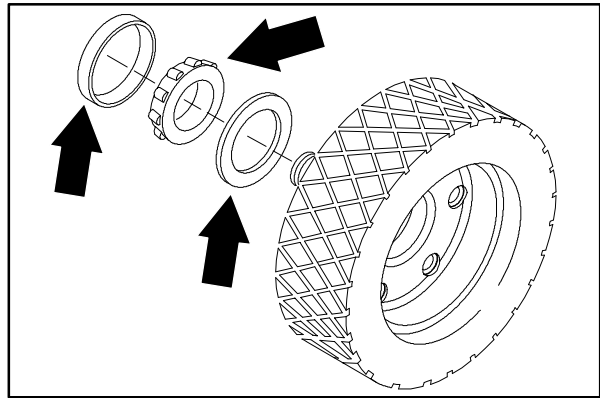

10. Press a new inner wheel bearing on the wheel shaft. Apply grease to the new bearing.

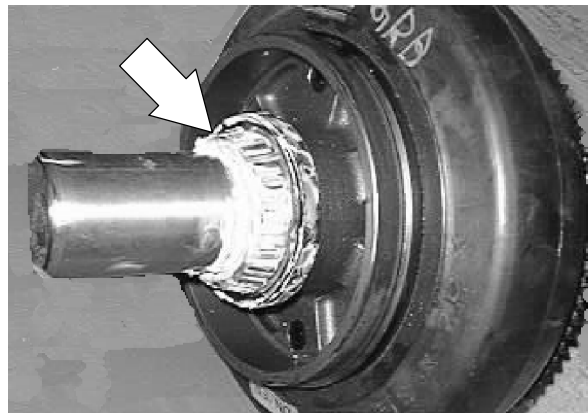

11. Reinstall the tire/wheel assembly in the drive assembly. Make sure the inner and outer wheel bearings are completely greased when re-assembling.

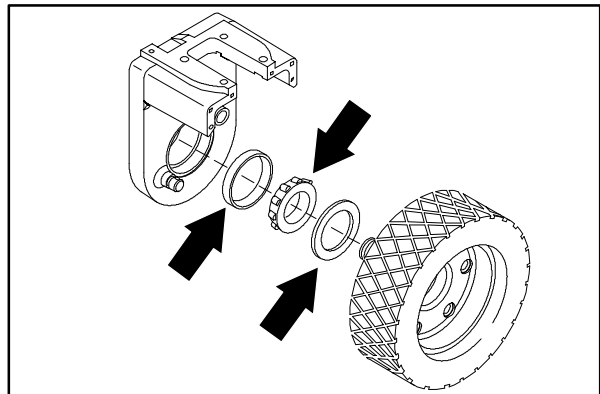

12. Reinstall the outer bearing and hex sleeve assembly. **(this is a left hand thread nut)** Tighten to at least 100 ft lbs and then back off the hex sleeve to 0 ft lbs. Re-torque hex sleeve to 30 ft lbs.

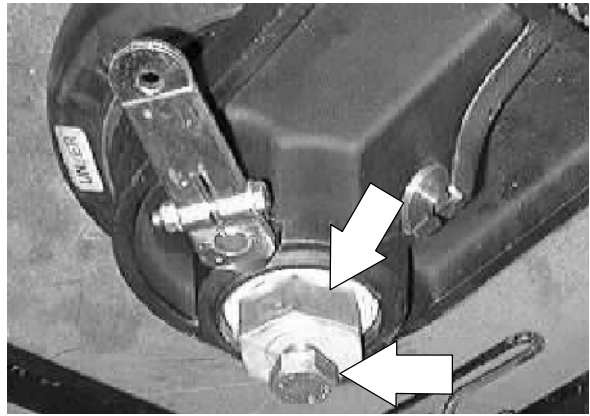

13. Install the lock bolt in the end of the hex sleeve. Tighten the lock bolt to 200 Nm (150 ft lb) while holding the hex sleeve from turning.

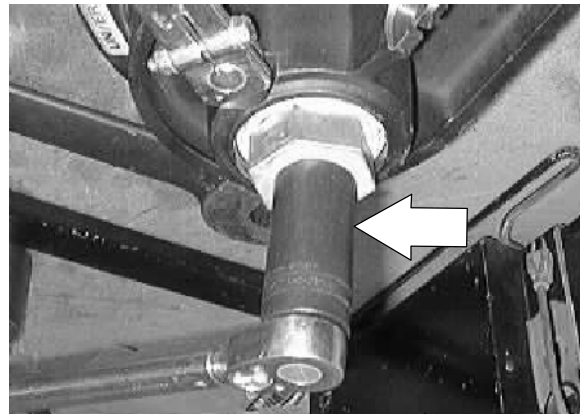

14. Reinstall the hub cap in the drive assembly.

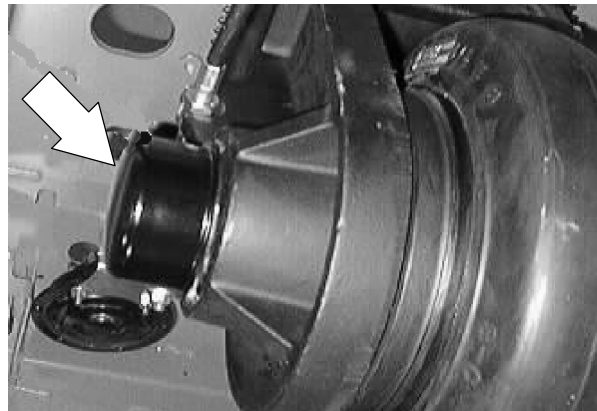

15. Go to the other side of the drive assembly. Install the planetary gear box, outer plate, and motor assembly into the wheel assembly and onto the pins of the drive assembly.

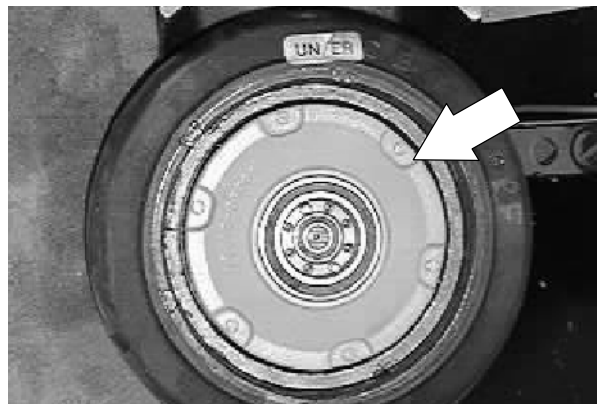

CHASSIS

16. Install the 4 hex screws and washers.
Tighten to 18 - 24 Nm (15 - 20 ft lb).

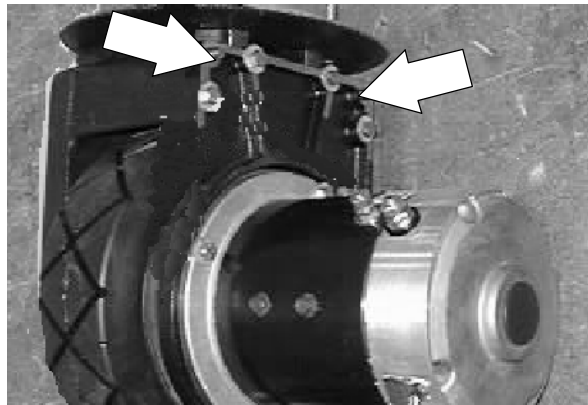

17. Reconnect the electrical cables to the drive motor.

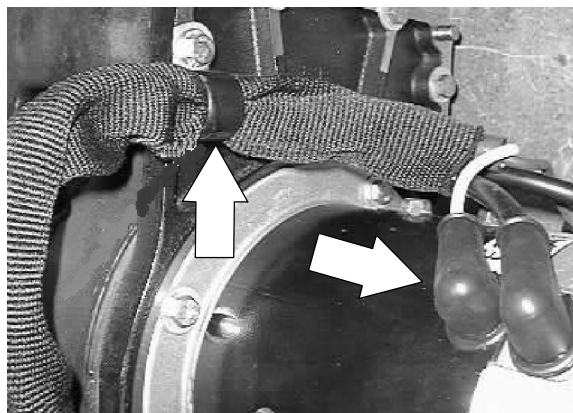

18. Remove the jack stands and lower the machine.

19. Reconnect the battery cables.



20. Drive the machine and check for proper operation.

STEERING

The steering on the model 6200E is controlled with two sprockets and one chain. A large diameter sprocket is mounted on the top of the front drive assembly and a small diameter sprocket is mounted on the bottom of the steering shaft. The steering chain runs around both of these sprockets.

After extended use, the steering chain may stretch slightly. Any slack in the chain can be removed by following the adjustment procedure listed below.

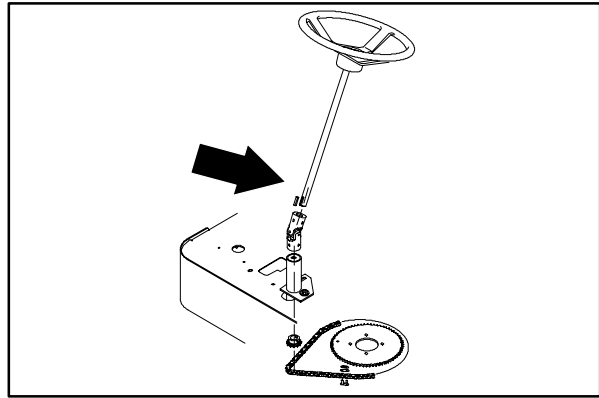

TO ADJUST STEERING CHAIN

FOR SAFETY: Before Leaving Or Servicing Machine; Stop On Level Surface, Set Parking Brake.

1. Go into the operators compartment and locate the two hex screws holding the lower steering shaft bearing assembly to the floor plate. Loosen these two hex screws.

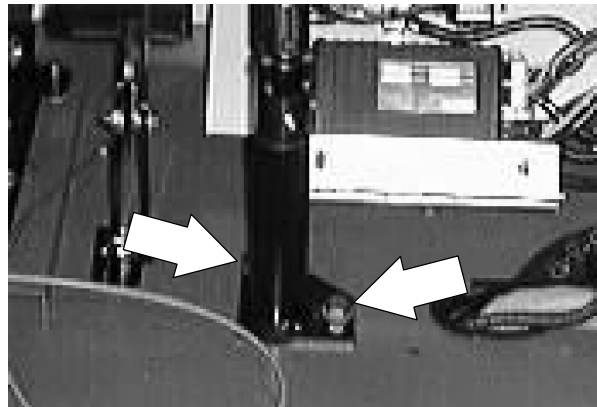

2. Push the lower steering shaft assembly forward until the slack has been removed from the steering chain. Tighten the two hex screws to 18 - 24 Nm (15 - 20 ft lb).

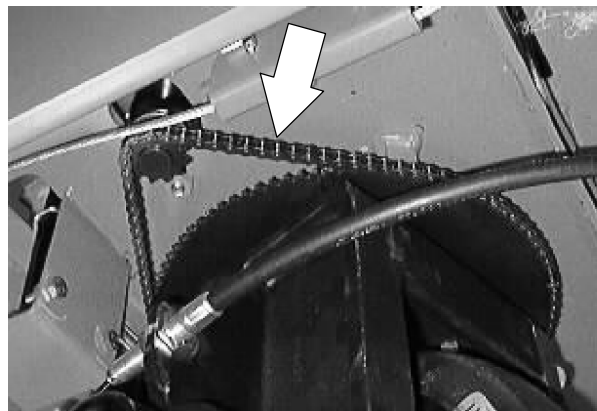

3. Operate the machine and check the steering for proper operation.

NOTE: There is also a half link that can be removed for more adjustment.

TO REPLACE STEERING CHAIN

FOR SAFETY: Before Leaving Or Servicing Machine; Stop On Level Surface, Set Parking Brake.

1. Raise the seat support and unplug the battery connectors.
2. Raise the front of the machine and place jack stands under the frame.
3. Go under the machine and locate the steering chain.

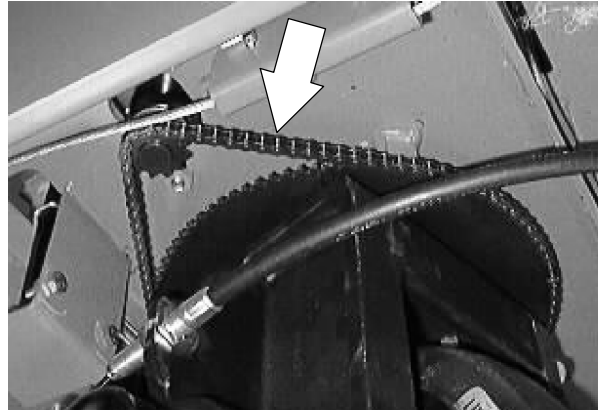

4. Rotate the steering wheel until the master link on the chain is accessible.
5. Remove the chain master link. Remove the steering chain from both sprockets.
6. Remove and discard the steering chain from the machine.

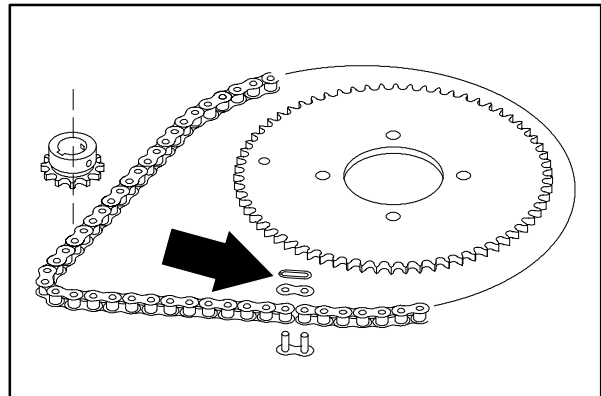

7. Route the new chain around both steering sprockets. Install the master link.
8. Remove the jack stands and lower the machine.
9. Operate the machine and check the steering for proper operation.

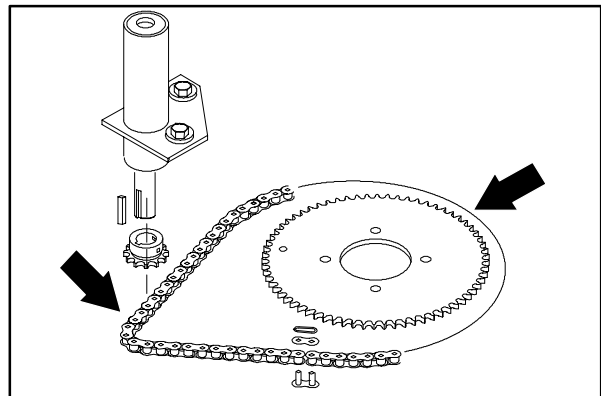

TO REPLACE LARGE STEERING SPROCKET

FOR SAFETY: Before Leaving Or Servicing Machine; Stop On Level Surface, Set Parking Brake.

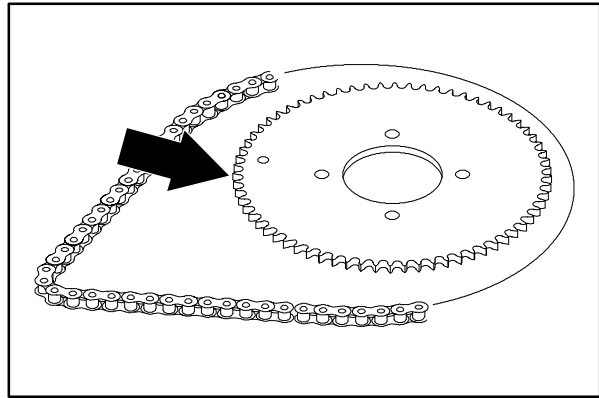

1. Remove the drive assembly from the machine. See TO REMOVE FRONT DRIVE ASSEMBLY instructions.

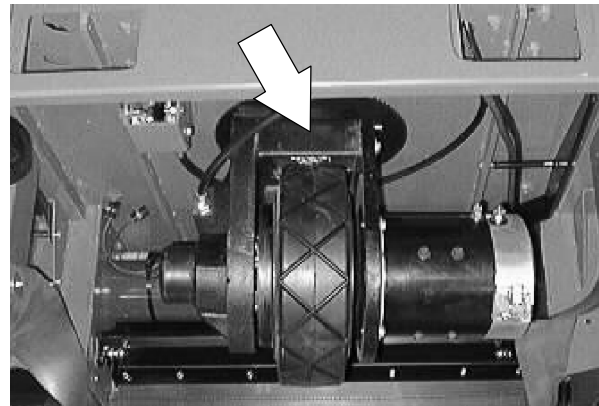

2. Remove the four hex screws holding the pivot and sprocket assembly to the drive assembly.
3. Remove the old sprocket from the pivot assembly.

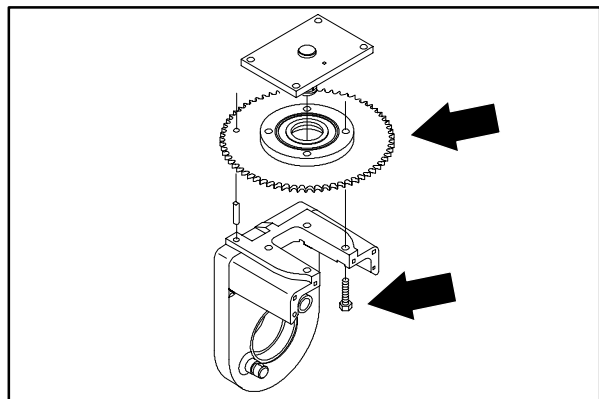

4. Install the new sprocket on the pivot assembly.

NOTE: Make sure the roll pin in the top of the drive assembly lines up with the hole in the sprocket.

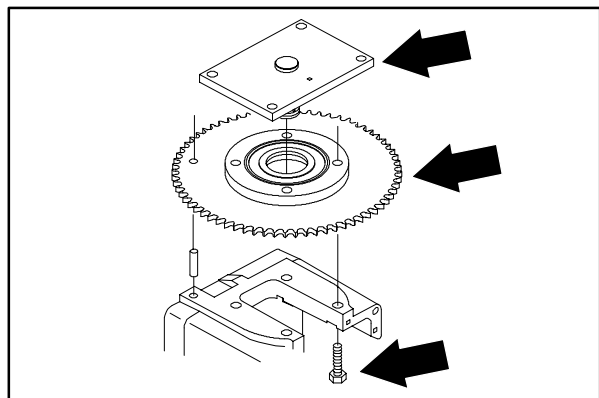

CHASSIS

5. Reinstall the pivot and sprocket assembly on the drive assembly. Reinstall the four screws and tighten to 68 - 81 Nm (50 - 60 ft lb).

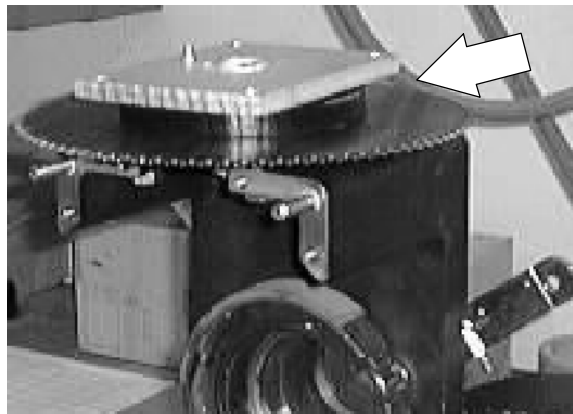

6. Reinstall the drive assembly in the machine. See TO INSTALL FRONT DRIVE ASSEMBLY instructions.

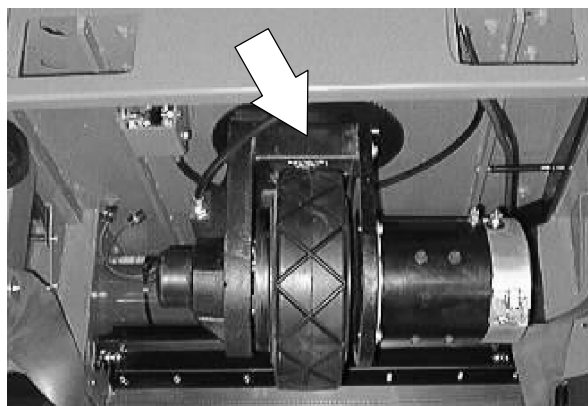

7. Operate the machine and check for smooth steering operation.

TO REPLACE SMALL STEERING SPROCKET

FOR SAFETY: Before Leaving Or Servicing Machine; Stop On Level Surface, Set Parking Brake.

1. Raise the seat support and unplug the battery connectors.
2. Raise the front of the machine and place jack stands under the frame.

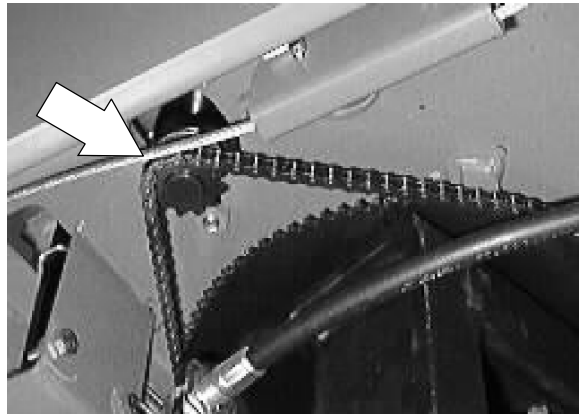

3. Go into the operators compartment and locate the lower steering shaft mount assembly. Loosen the two screws and pull the mount back to give the steering chain slack.

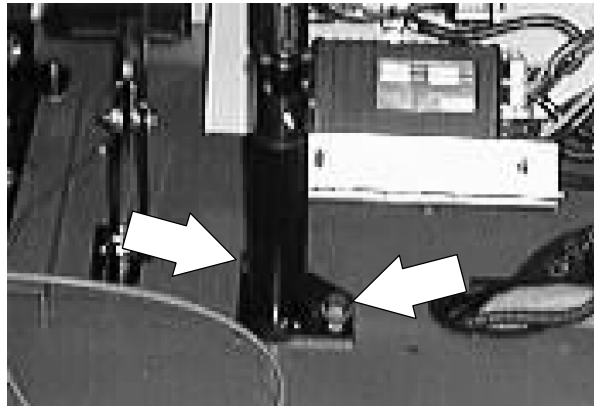

4. Go under the machine and locate the steering chain.

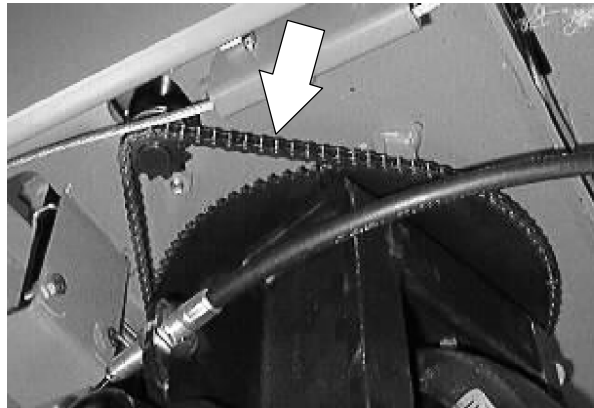

5. Rotate the steering wheel until the master link on the chain is accessible.

6. Remove the chain master link. Remove the steering chain from both sprockets.

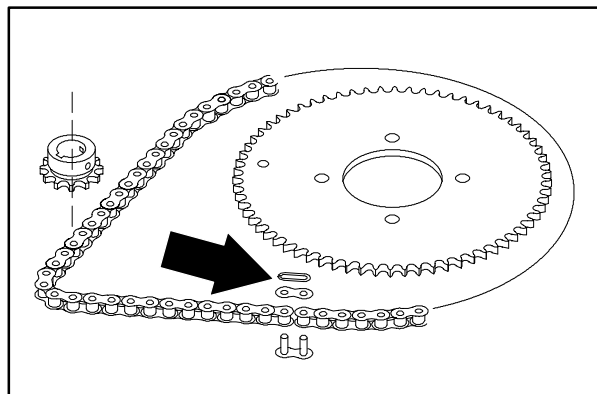

CHASSIS

7. Loosen the set screws holding the small sprocket to the lower shaft. Slip the small sprocket off the shaft.

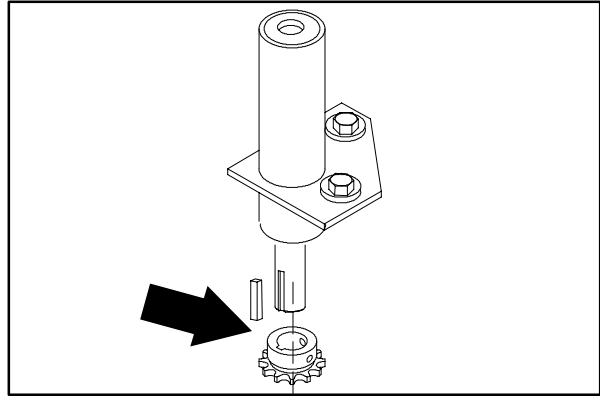

8. Install the new small sprocket on the lower steering shaft. Firmly tighten the set screws.

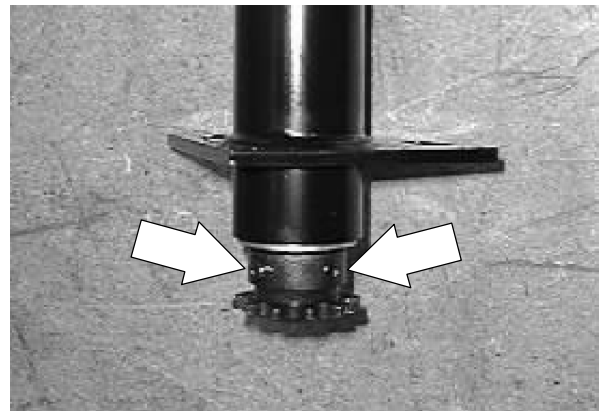

9. Route the steering chain around both steering sprockets. Install the master link.

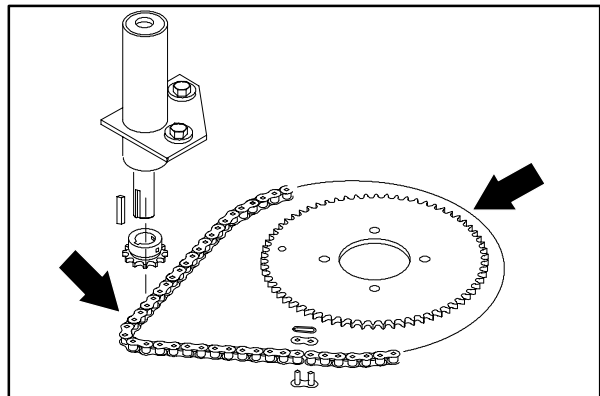

10. Adjust the steering chain. See TO ADJUST STEERING CHAIN instructions.
11. Remove the jack stands and lower the machine.
12. Operate the machine and check the steering for proper operation.

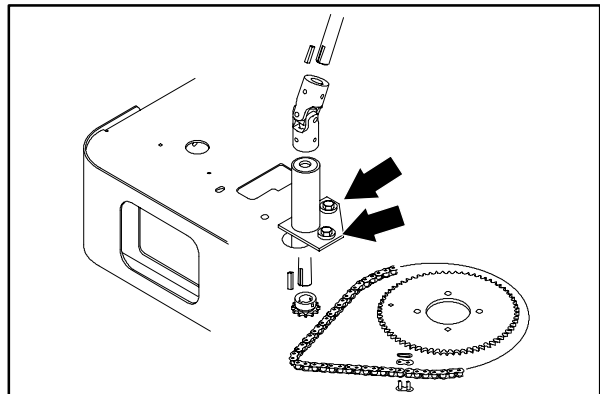

TO REPLACE STEERING HOUSING BEARINGS

FOR SAFETY: Before Leaving Or Servicing Machine; Stop On Level Surface, Set Parking Brake.

1. Jack up the front of the machine at the jack point. Install jack stands under the machine frame.
2. Turn the steering wheel all the way to the left.
3. Go to the operators compartment and locate the steering U-joint. Loosen the two set screws on the top of the steering U-joint.
4. Pull the steering wheel and long steering shaft up and out of the top of the steering U-joint.
5. Remove the two hex screws holding the steering bearing housing to the machine frame. Push the bearing housing back in the slots.

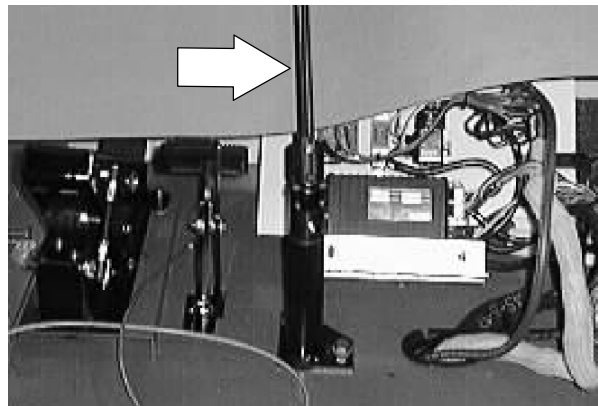
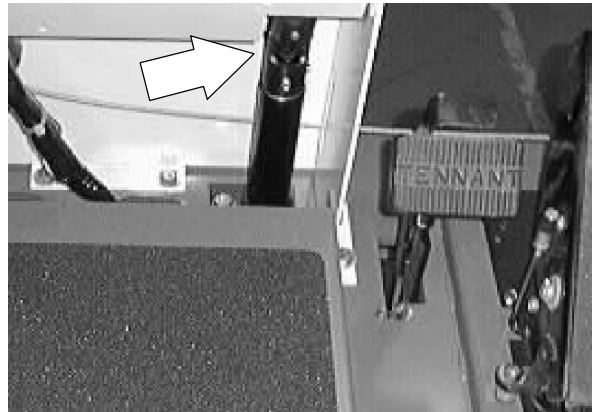
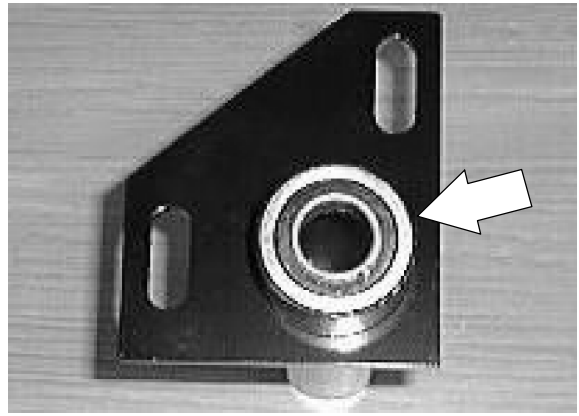

CHASSIS

6. Go under the machine and locate the small steering chain sprocket.

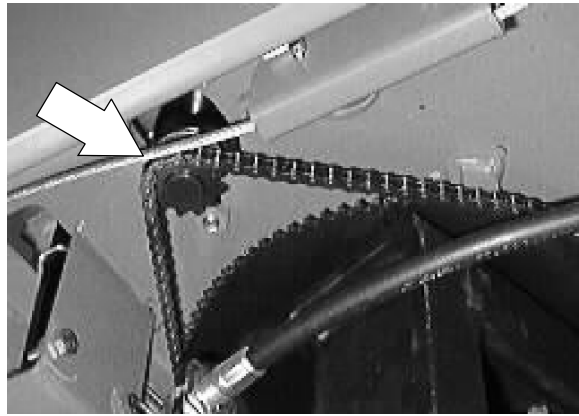

7. Locate the master link on the steering chain. Remove the master link and steering chain from the small steering sprocket.

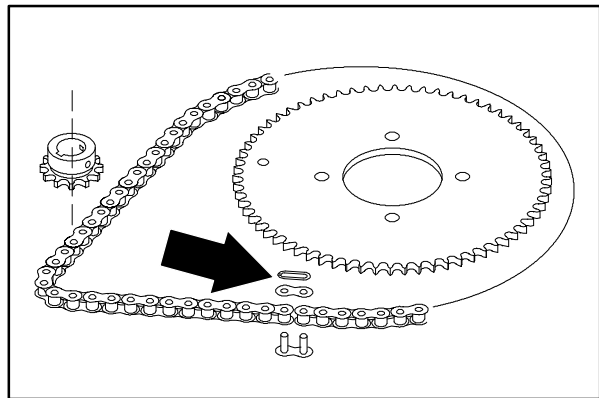

8. Remove the steering housing from the machine.

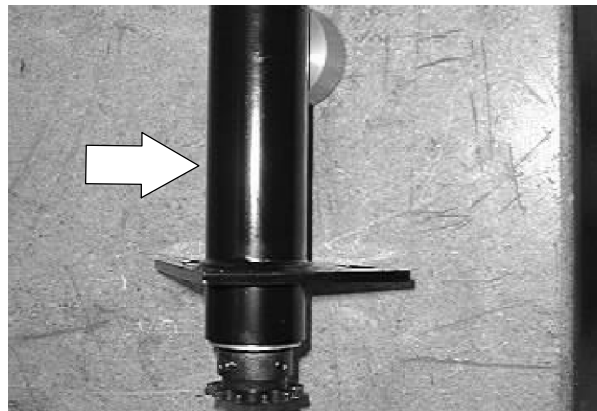

9. Loosen the two set screws holding the U-joint to the top of the short steering shaft. Remove and retain the U-joint and square key.

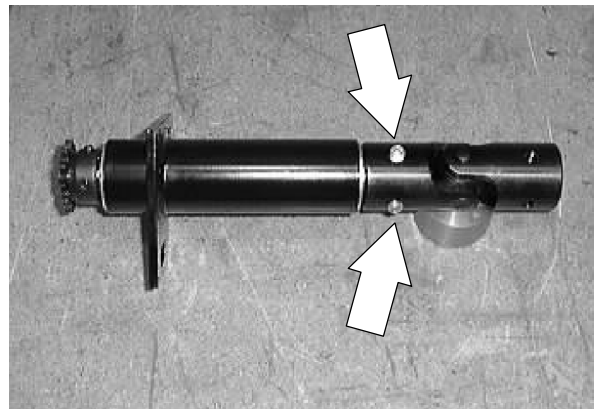

10. Loosen the set screw holding the small steering sprocket to the bottom of the short steering shaft. Remove and retain small sprocket and woodruff key.

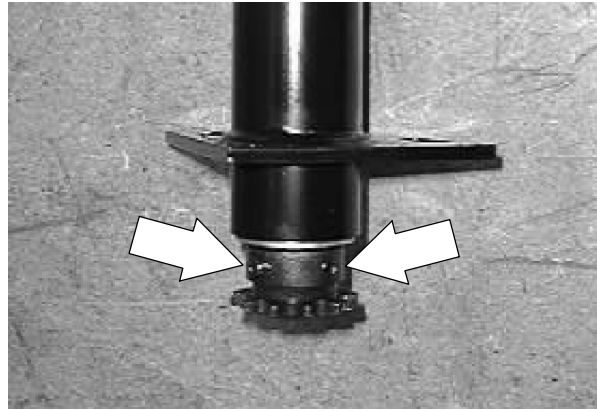

11. Use an arbor press to press the short steering shaft and two bearings out of the housing. Discard the bearings. Retain the short shaft. *Note the orientation of the shaft in the housing.*
12. Use the arbor press to install the new bearings into the steering housing.

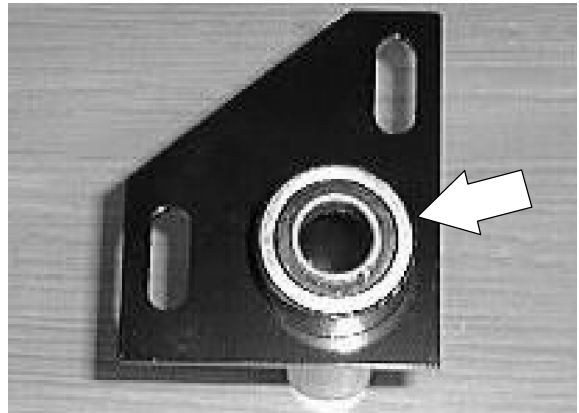

13. Use the arbor press to install the short steering shaft into the new bearings.

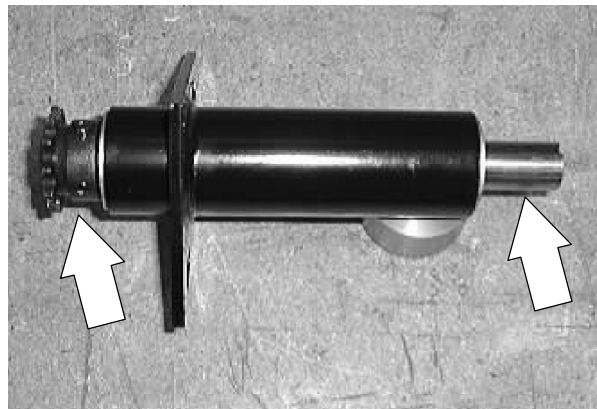

14. Reinstall the small steering sprocket and woodruff key on the bottom of the steering housing. Tighten the set screws tight.

15. Reinstall the U-joint and square key on the top of the steering housing. Tighten the set screws tight.

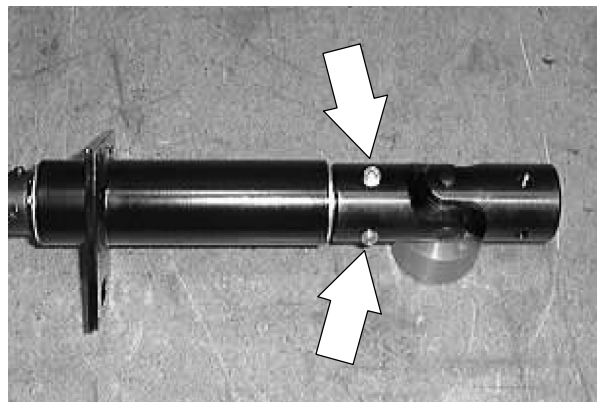

CHASSIS

16. Reinstall the steering housing in the machine. Reinstall the two hex screws. Leave loose for now.

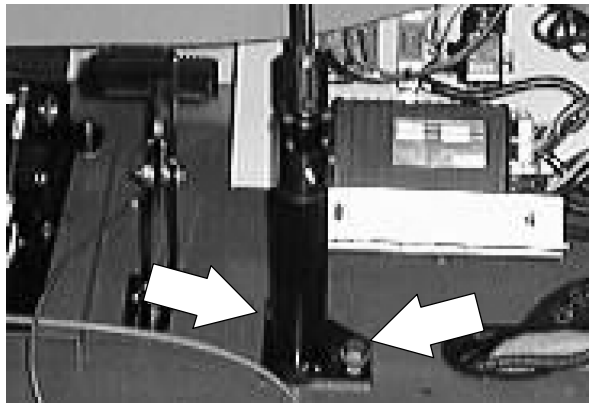

17. Position the long steering shaft and steering wheel into the top of the steering U-joint. Tighten the set screws tight.

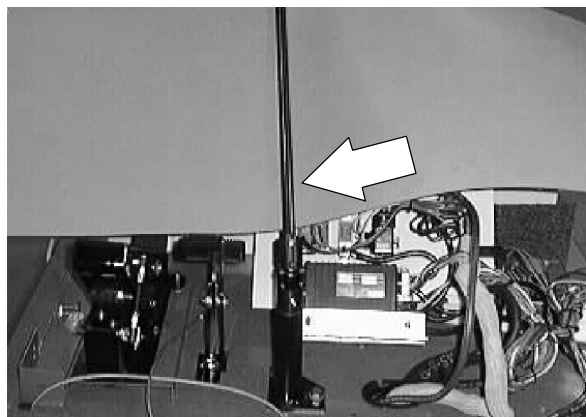

18. Go under the machine and reinstall the steering chain around the small steering sprocket. Reinstall the master link.
19. Turn the steering wheel all the way to the left and then to the right. Find the point in the rotation where the steering chain is the most tight.

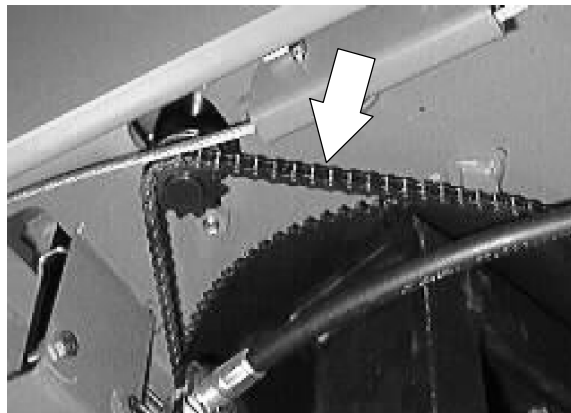

20. Push the bearing housing forward in the slots. This will remove any excess slack in the steering chain. Tighten the two hex screws to 37 – 48 Nm (26 – 34 ft lb).

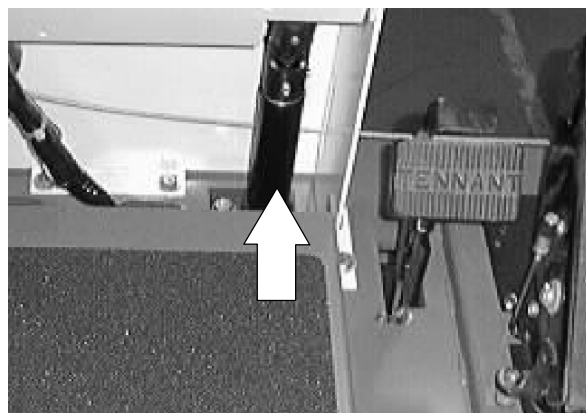

21. Remove the jack stands and lower the machine to the floor. Operate the machine and check the steering chain for proper operation.

TO REPLACE STEERING U-JOINT

FOR SAFETY: Before Leaving Or Servicing Machine; Stop On Level Surface, Set Parking Brake.

1. Jack up the front of the machine at the jack point. Install jack stands under the machine frame.
2. Go to the operators compartment and locate the steering U-joint. Loosen the two set screws on the top of the steering U-joint.

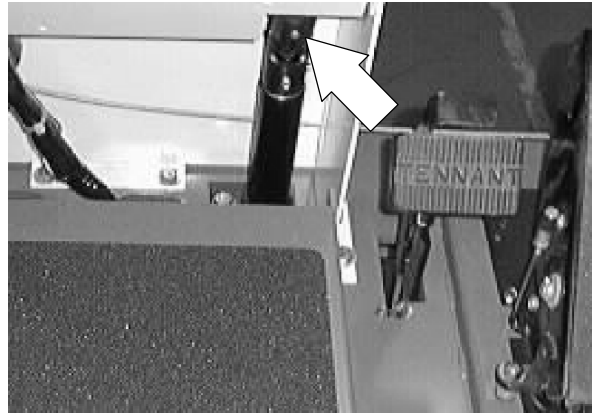

3. Pull the steering wheel and long steering shaft up and out of the top of the steering U-joint.

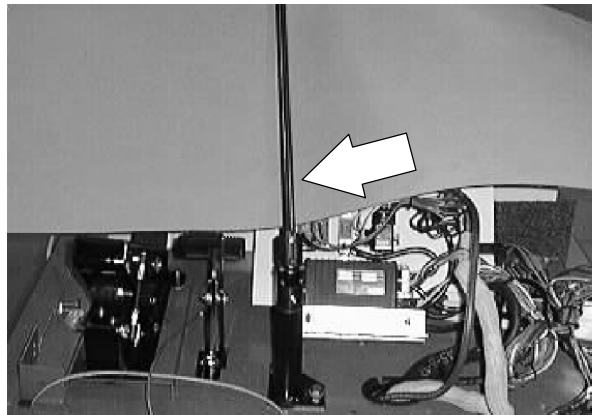

4. Loosen the two set screws holding the U-joint to the top of the short steering shaft. Remove and discard the U-joint and square key.

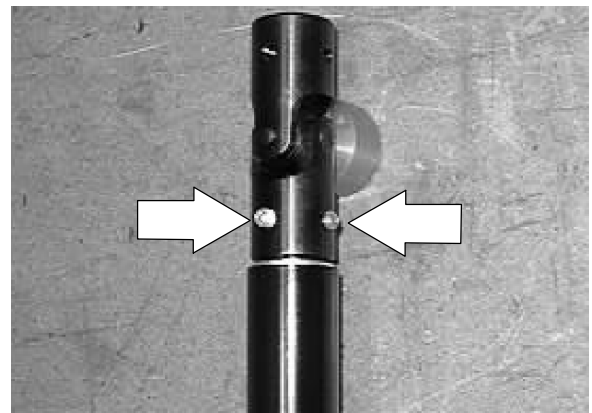

CHASSIS

5. Install the new U-joint and square key on the top of the steering housing. Tighten the set screws tight.

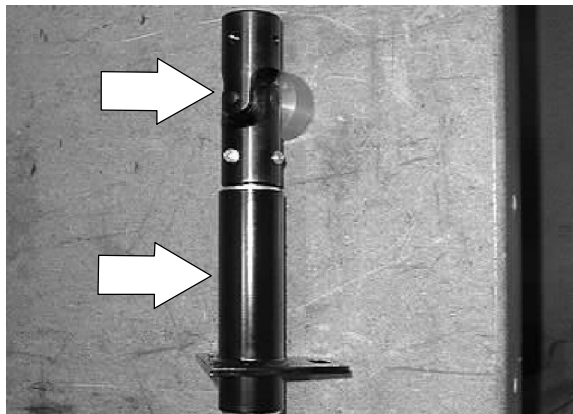

6. Position the long steering shaft and steering wheel into the top of the steering U-joint. Tighten the set screws tight.

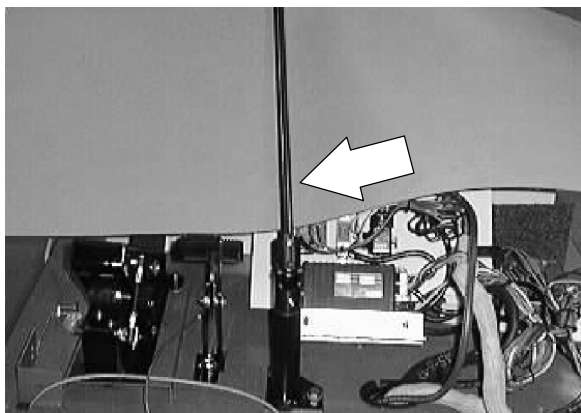

7. Operate the machine and check the steering U-joint for proper operation.

CONTENTS

	Page
INTRODUCTION	3-3
DEBRIS HOPPER	3-4
HOPPER DUST FILTER	3-5
TO REPLACE HOPPER DUST FILTER	3-6
MAIN BRUSH	3-10
TO REPLACE MAIN BRUSH	3-10
CHECKING AND ADJUSTING MAIN BRUSH PATTERN	3-12
MAIN BRUSH BELT	3-14
TO REPLACE MAIN BRUSH DRIVE BELT	3-14
TO REPLACE MAIN BRUSH IDLER PLUG BEARING	3-16
TO REPLACE MAIN BRUSH DRIVE PLUG SHAFT BEARINGS	3-19
TO REPLACE MAIN BRUSH DRIVE BELT IDLER PULLEY	3-24
SIDE BRUSH	3-26
TO REPLACE SIDE BRUSH	3-26
SIDE BRUSH GUARD	3-28
SIDE BRUSH PIVOT	3-28
TO REPLACE SIDE BRUSH LIFT CABLE	3-29
SKIRTS AND SEALS	3-32
REAR SKIRT	3-32
SIDE SKIRTS	3-32
LARGE DEBRIS TRAP SKIRT	3-33
HOPPER SEALS	3-33
HOPPER DOOR SEAL	3-34
HOPPER LIP SEAL	3-34
FRONT SKIRT	3-34
VACUUM FAN	3-35
VACUUM FAN BELT	3-35
TO REPLACE VACUUM FAN DRIVE BELT	3-36
TO ADJUST VACUUM FAN DRIVE BELT TENSION	3-39
TO REPLACE VACUUM FAN IMPELLER	3-40
TO REPLACE VACUUM FAN IMPELLER BEARINGS	3-45
MACHINE TROUBLESHOOTING	3-48

INTRODUCTION

This section includes information on the sweeping operation of the model 6200E. The side brush sweeps debris in front of the machine and the main brush sweeps the debris into the hopper. The vacuum fan pulls air from the hopper and through the dust filter.

DEBRIS HOPPER

The hopper is located at the rear of the machine behind the battery compartment.

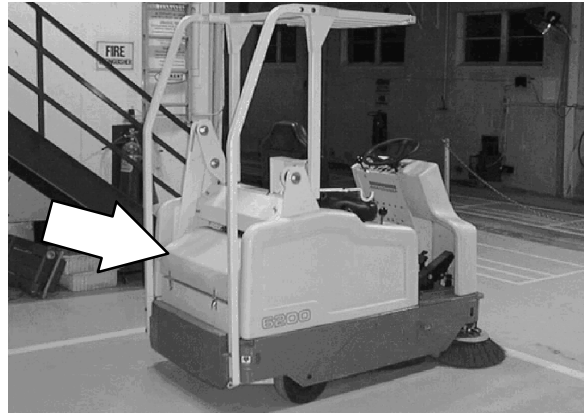

The hopper is raised and lowered with an hydraulic lift cylinder. The lift cylinder is provided hydraulic flow from a electro/hydraulic unit. The electro/hydraulic unit is activated with a dash mounted switch.



The hopper is held in the raised position with a prop arm.

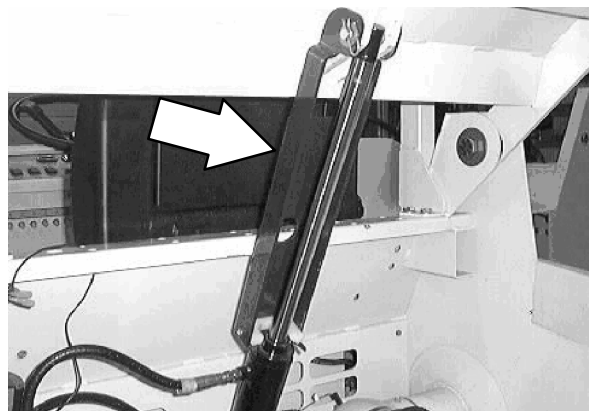

HOPPER DUST FILTER

The Instant Access™ hopper filter filters the air pulled up from the hopper. The dust filter is equipped with a shaker to remove the accumulated dust particles. The dust filter shaker is operated by the main brush, vacuum and filter shaker switch.

Shake the dust filter before emptying the hopper and at the end of every work shift. Check and clean or replace the dust filter after every 100 hours of operation.

To clean the Instant Access™ filter, use one of the following methods:

- **SHAKING** - Press and hold the main brush, vacuum and filter shaker switch to the **Filter shaker** position.
- **TAPPING** - Remove the filter and tap the filter gently on a flat surface with the dirty side down. Do not damage the edges of the filter element and seals, or the filter will not seat properly in the filter frame.
- **AIR** - Blow air through the dust filter, opposite the direction of the arrows. This may be done with the dust filter in the machine. Always wear eye protection when using compressed air.

FOR SAFETY: When servicing machine, wear eye and ear protection if using pressurized air or water.

- **WATER** - Soak the dust filter in a water and mild detergent solution. Rinse the dust filter until it is clean. Air dry the wet dust filter; do not use compressed air to dry a wet filter.

NOTE: Be sure the dust filter is completely dry before reinstalling it in the machine.

SWEEPING

TO REPLACE HOPPER DUST FILTER

FOR SAFETY: Before Leaving Or Servicing Machine; Stop On Level Surface, Set Parking Brake.

1. Stop the machine, set the parking brake and turn the machine power off.

FOR SAFETY: Before leaving or servicing machine, stop on level surface, set parking brake, turn off machine, and remove key.

2. Unlatch and remove hopper cover.

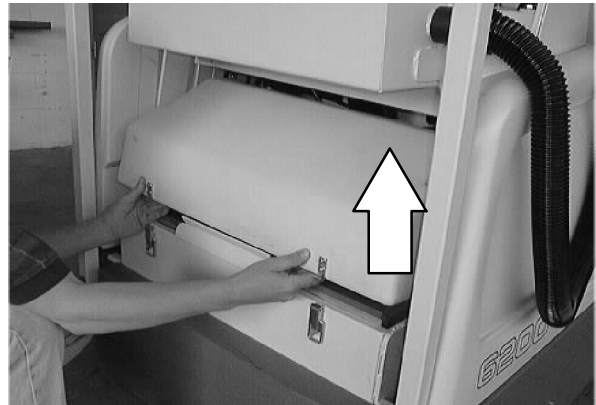

3. Unplug the filter shaker from the main harness.

NOTE: Carefully pull the wires apart from the bodies of the plugs Do not unplug the connections from the shaking mechanism. Do not pull on the wires. Damage could occur to the wires or the shaking mechanism.

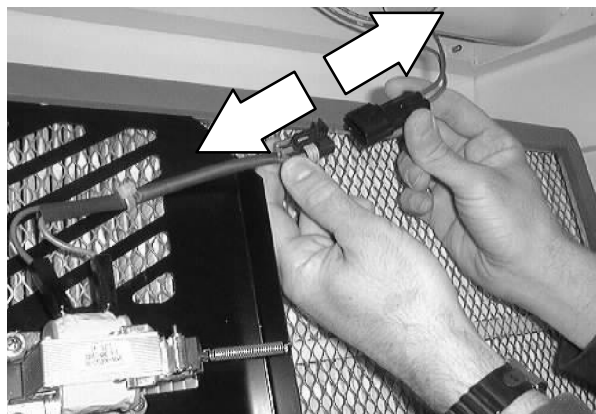

4. Lift dust filter assembly out of hopper.

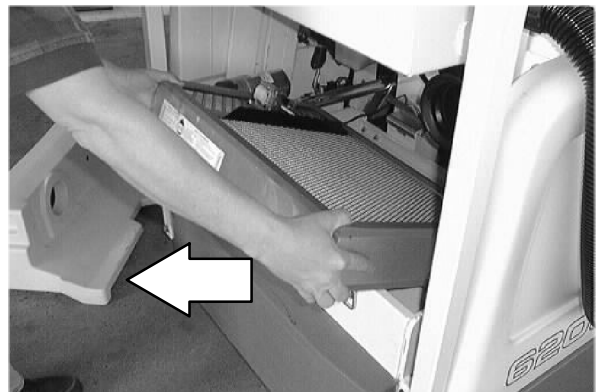

5. Pull back on the tension spring, releasing tension from the shaking mechanism.

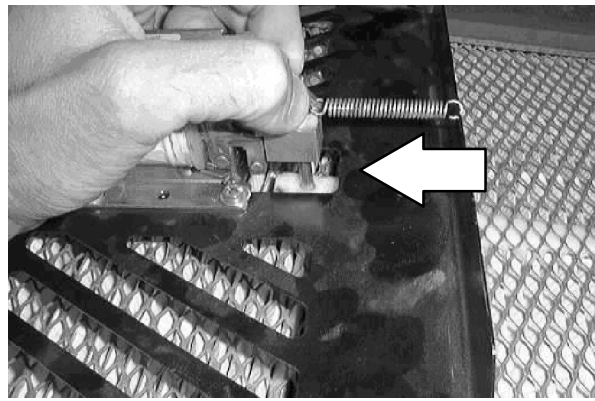

6. Lift the VCS™ system filter shaker off of the filter.

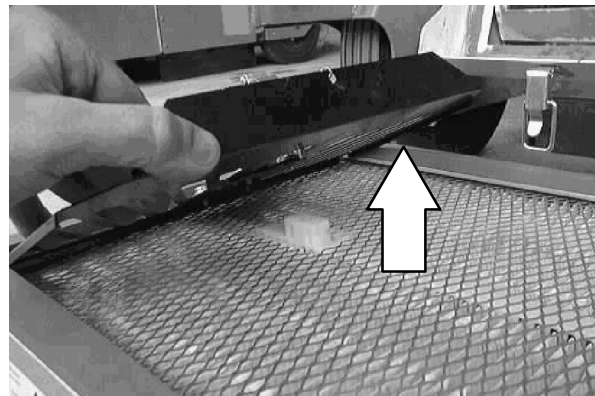

7. Clean or discard the Instant Access™ filter as required.

8. Replace the VCS™ system filter shaker. Use care to insert the shaking pin into the filter comb correctly.

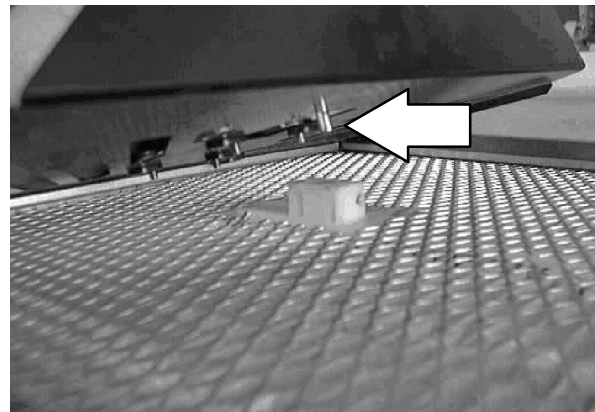

SWEEPING

9. Place the edges of the shaker firmly between the filter and the filter seal.

NOTE: When installed properly, the shaker plate cannot move in either front-to-back or side-to-side directions. If the shaker is loose, it will not function properly.

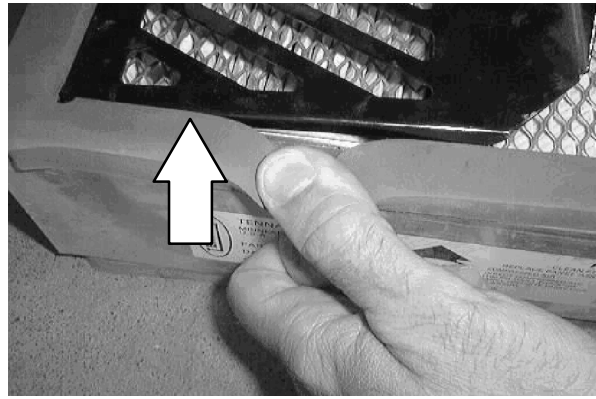

10. The filter shaker should lay flat against the filter. Check to make sure the comb tab is not caught below the filter shaker plate.

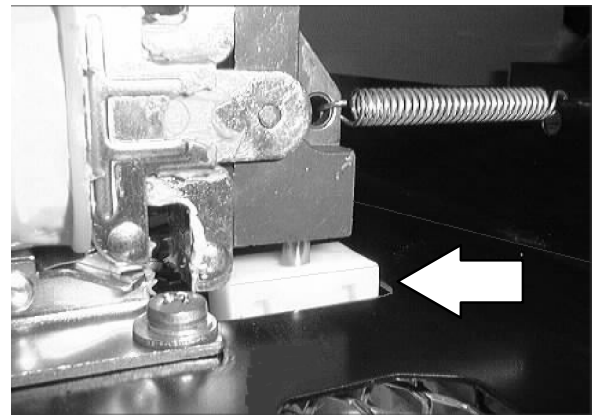

11. Check the shaker solenoid gap with the end of the shipping tab. The gap should be the same width as the tab. If it is not, loosen the mounting screws, adjust the gap by repositioning the shaker solenoid, then retighten the screws.

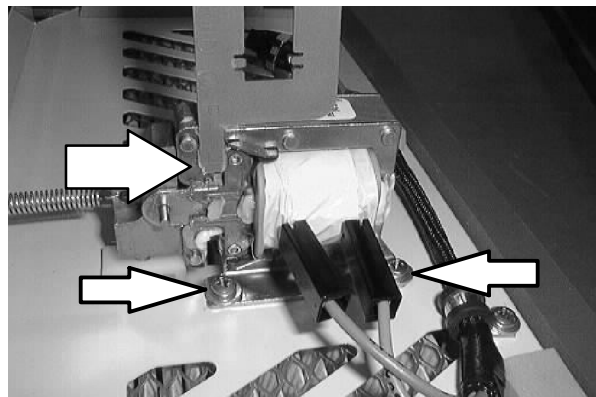

12. Return the filter back to the machine.

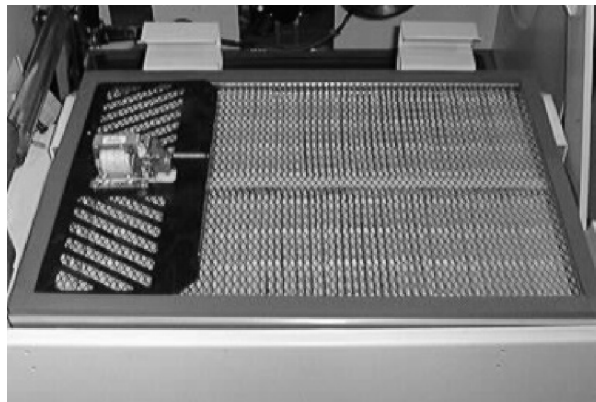

13. Reconnect the main harness to the shaker mechanism.

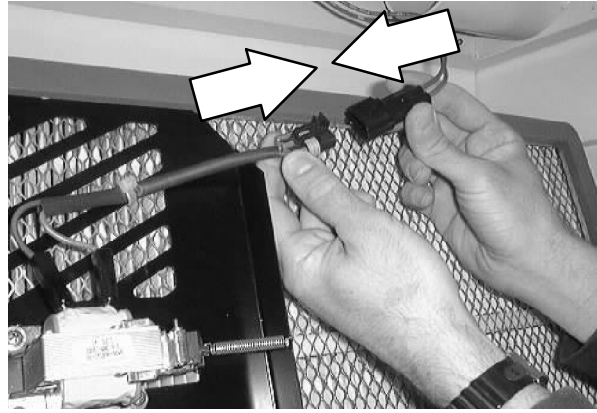

14. Check the dust filter seals.

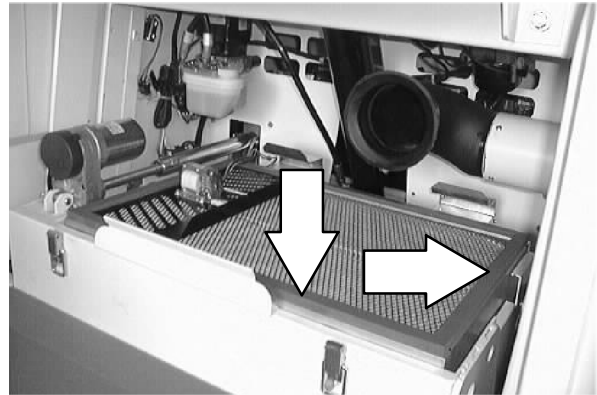

15. Replace hopper cover and secure with latches.

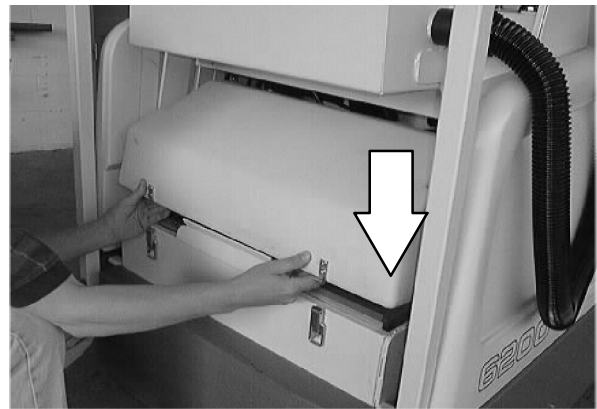

SWEEPING

MAIN BRUSH

The main brush is cylindrical and spans the width of the machine, sweeping debris into the hopper.

Check the brush daily for wear or damage. Remove any string or wire tangled on the main brush, main brush drive hub, or main brush idler hub.

Check the main brush pattern weekly. The pattern should be 50 to 75 mm (2 to 3 in) wide with the main brush in the lowered position.

Rotate the main brush end-for-end after every 50 hours of operation for maximum brush life and best sweeping performance.

Replace the main brush when the remaining bristles measure 25 mm (1 in) in length.

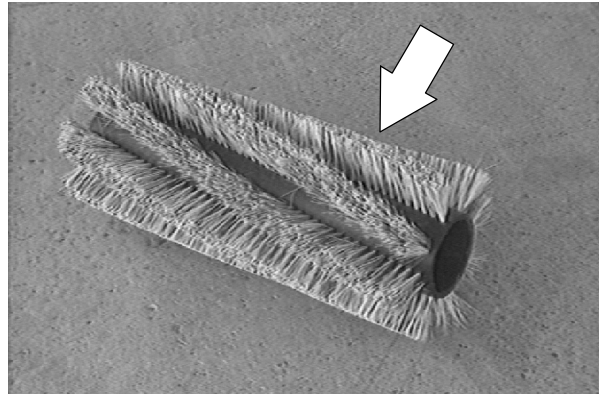

TO REPLACE MAIN BRUSH

FOR SAFETY: Before Leaving Or Servicing Machine; Stop On Level Surface, Set Parking Brake.

1. Stop the machine, set the parking brake and turn the machine power off.
2. Open the left side main brush access door.

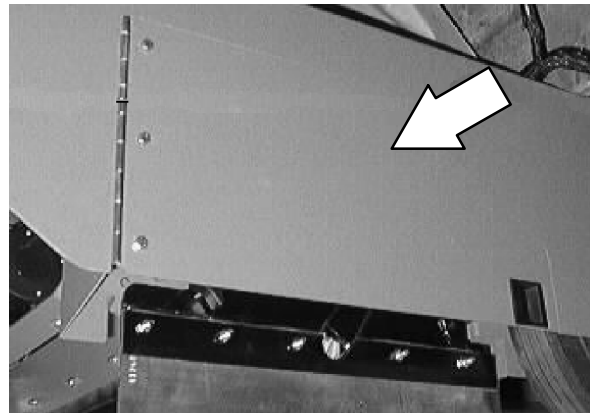

3. Loosen the idler arm mounting knob and three other side skirt mounting knobs. Remove the brush idler arm assembly.

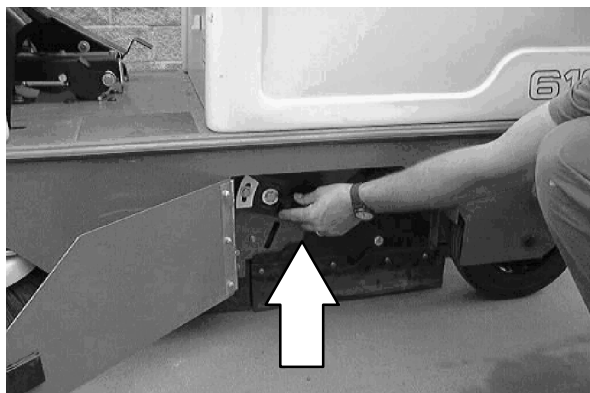

4. Grasp the main brush; pull it off the brush drive plug and out of the main brush compartment.
5. Put the new or rotated end-for-end main brush on the floor next to the access door.
6. Slide the main brush onto the drive plug. Rotate the brush until it engages the drive plug, and push it all the way onto the plug.



7. Check that the recirculation skirt is tucked in behind the frame.
8. Slide the main brush idler arm plug onto the main brush.

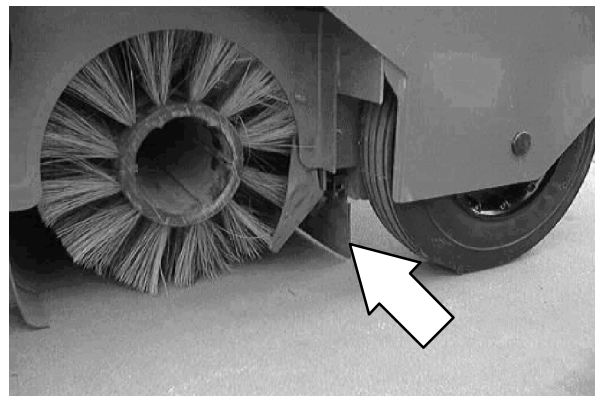

9. Secure the idler arm on the bolts. Hand tighten the mounting knobs.

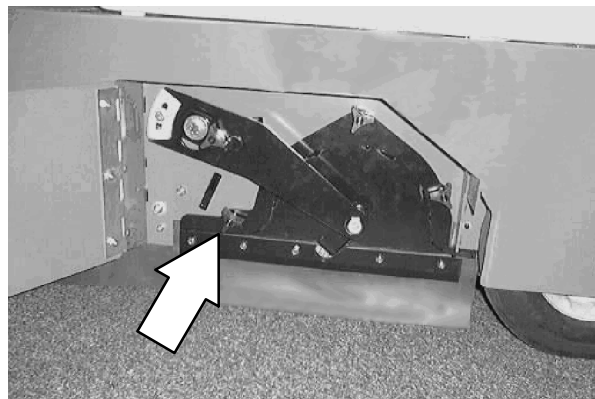

10. Close the main brush access door.

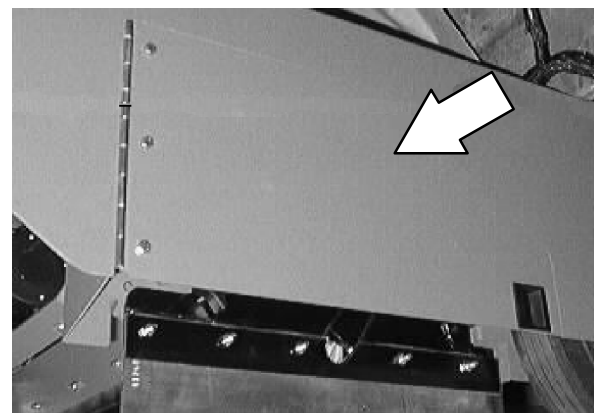

SWEEPING

CHECKING AND ADJUSTING MAIN BRUSH PATTERN

1. Apply chalk, or some other material that will not blow away easily, to a smooth, level floor.
2. Raise the side brush and main brush and position the main brush over the chalked area.
3. Start and lower the main brush for 15 to 20 seconds while keeping a foot on the brakes to keep the machine from moving.

NOTE: If chalk or other material is not available, allow the brushes to spin on the floor for two minutes. A polish mark will remain on the floor.

4. Raise the main brush.
5. Drive the machine off the test area.
6. Observe the width of the brush pattern. The proper brush pattern width is 50 to 75 mm (2 to 3 in).

The brush taper is factory set and should not need adjustment unless parts of the brush system have been replaced.

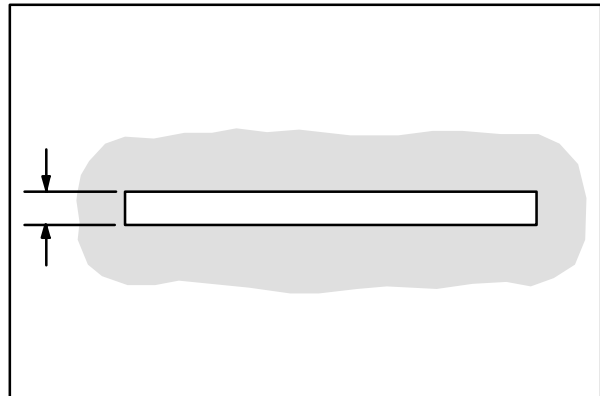

If the main brush pattern is tapered, more than 15 mm (0.5 in) on one end than the other, adjust the taper as follows:

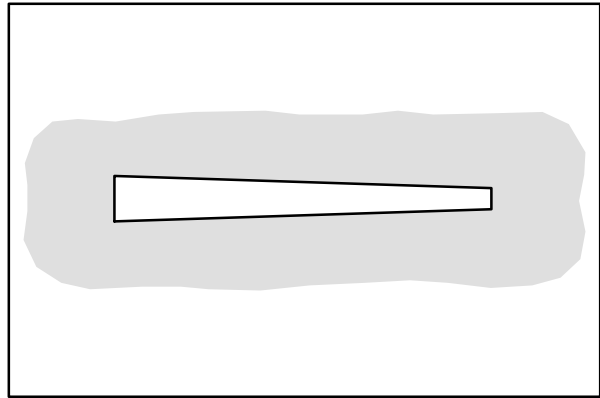

- A. Loosen the brush shaft bearing bracket mounting bolt and the idler arm securing head.
- B. Allow the brush to operate and float into position for approximately 30 seconds.
- C. Tighten the adjustment bolt and idler arm securing knob.
- D. Check the main brush pattern and readjust as necessary.

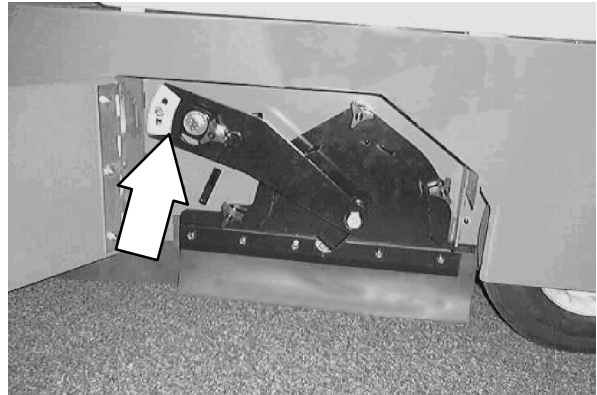

SWEEPING

MAIN BRUSH BELT

Check the main brush belt for wear after every 100 hours of operation. The idler keeps tension on the belt. The tension is set manually.



WARNING: Moving belt and fan. Keep away.

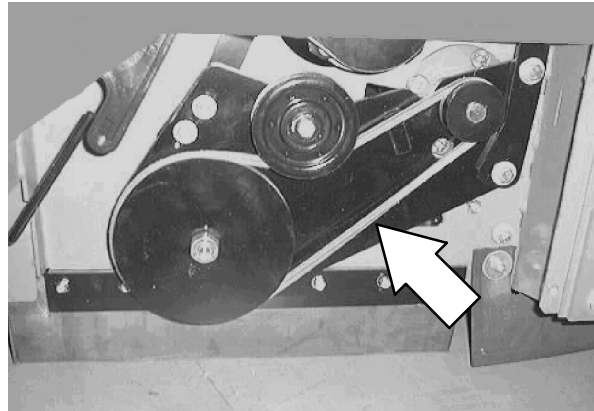

TO REPLACE MAIN BRUSH DRIVE BELT

FOR SAFETY: Before Leaving Or Servicing Machine; Stop On Level Surface, Set Parking Brake.

1. Remove the four screws holding the right hand brush door to the machine frame. Remove the right hand side brush door.

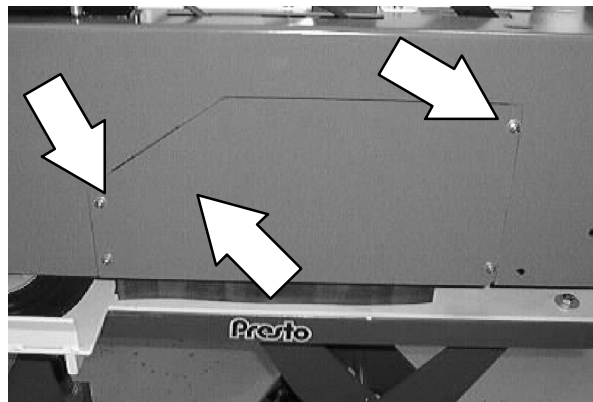

2. Locate the main brush drive belt idler pulley between the small motor drive pulley and the larger brush pulley.
3. Loosen the hex nut in the center of the idler pulley.
4. Push the idler pulley back in the slot.

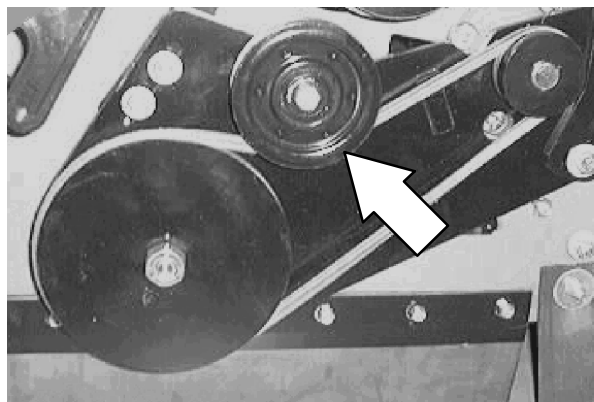

5. Remove the main brush drive belt from the two remaining pulleys. Remove and discard the old drive belt.

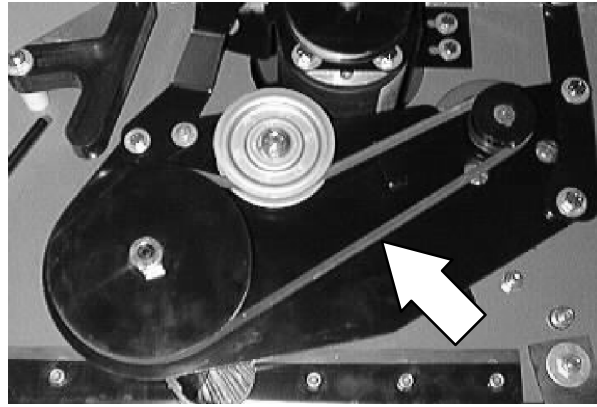

6. Position the new main brush drive belt onto the motor and brush drive pulleys.

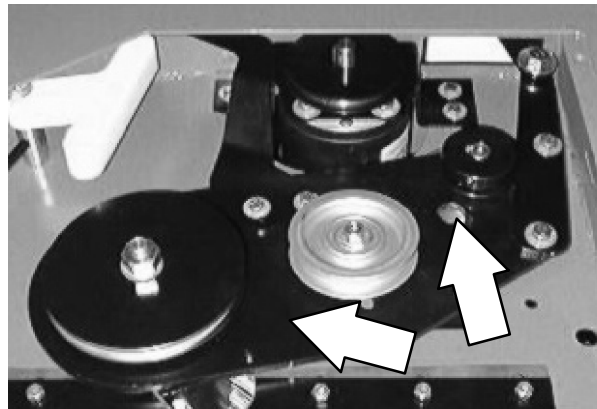

7. Move the idler pulley forward in the slot until the belt is tight. Tighten the hex nut to 18 - 24 Nm (15 - 20 ft lb).

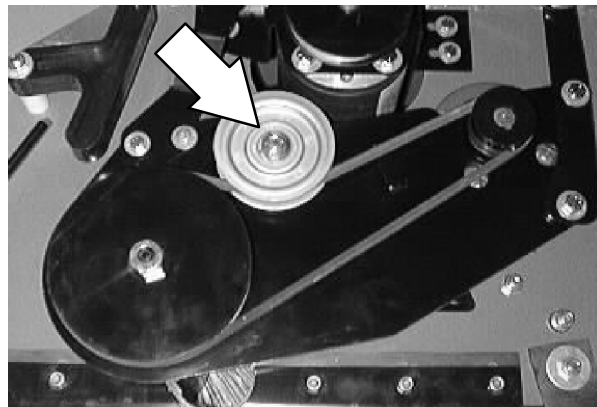

8. Reinstall the right hand side brush door.

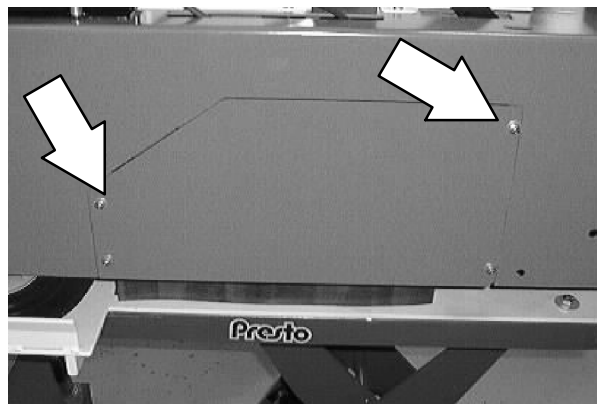

9. Operate the machine and check the main brush for proper operation.

SWEEPING

TO REPLACE MAIN BRUSH IDLER PLUG BEARING

**FOR SAFETY: Before Leaving Or
Servicing Machine; Stop On Level
Surface, Set Parking Brake.**

1. Open the left hand side brush door.
2. Remove the main brush idler mount plate.
See TO REPLACE MAIN BRUSH
instructions in this sections.

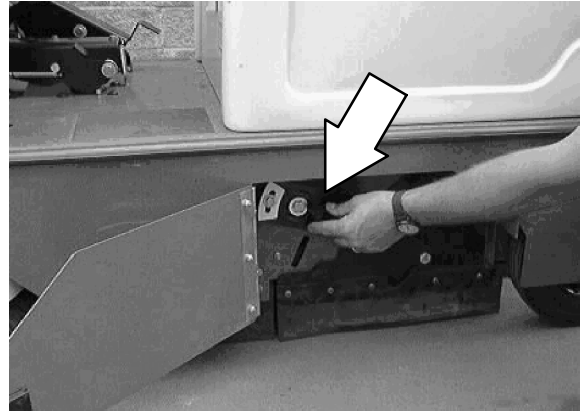

3. Remove the idler arm from the brush lift plate.

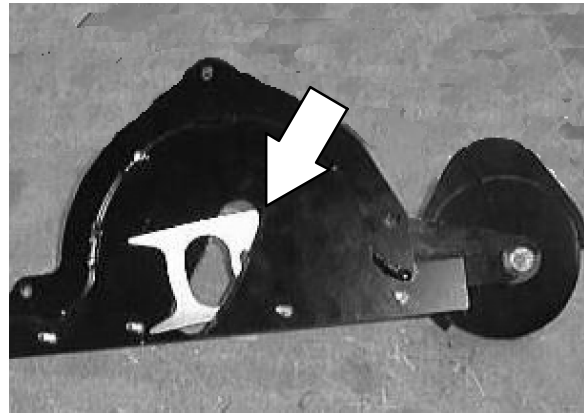

4. Remove the hex screw, nut, and washer holding the idler plug assembly to the brush lift plate.

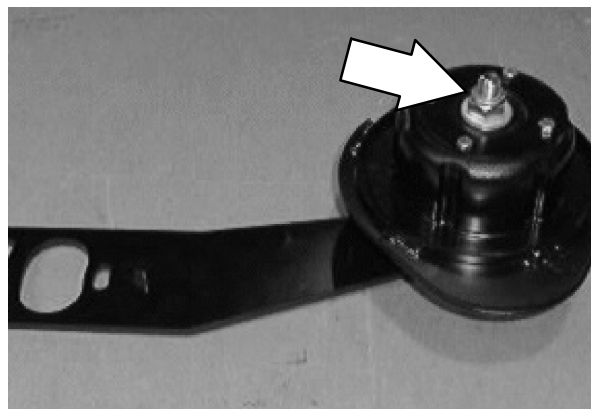

5. Remove the idler plug assembly from the lift plate.

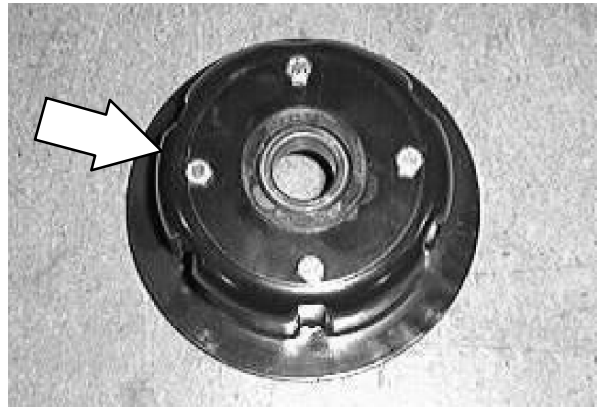

6. Remove the four hex screws holding the bearing retainer to the idler plug. Remove the retainer.

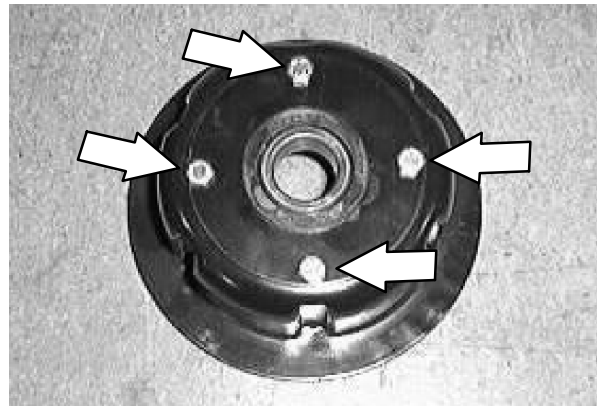

7. Remove and discard the idler ball bearing from the idler plug.
8. Position the new ball bearing into the idler plug.

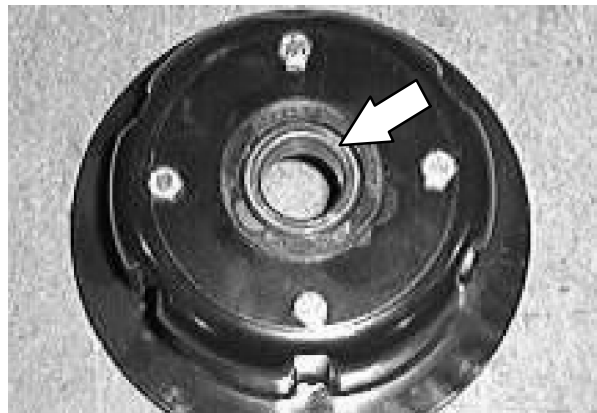

9. Reinstall the bearing retainer plate on the idler plug. Reinstall the four screws and tighten to 8 - 10 Nm (6 - 7 ft lb).

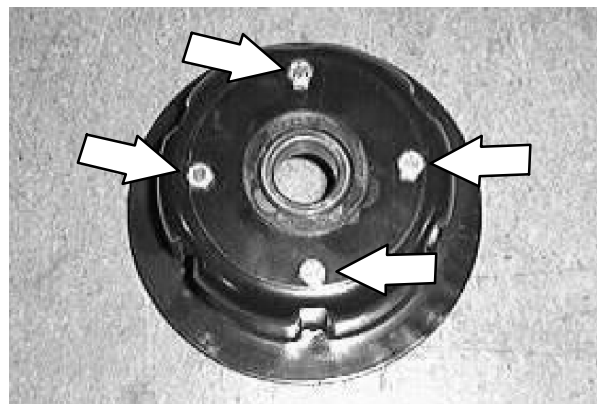

SWEEPING

10. Reinstall the idler plug assembly onto the brush lift plate. Reinstall the hex screw, washer, and nyloc nut. Tighten to 37 - 48 Nm (26 - 34 ft lb).

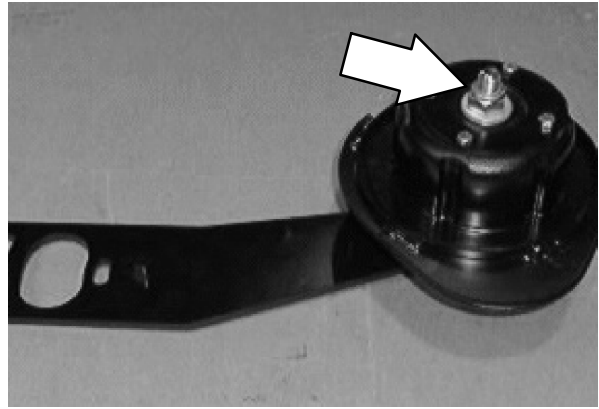

11. Reinstall the idler arm onto the brush lift plate.

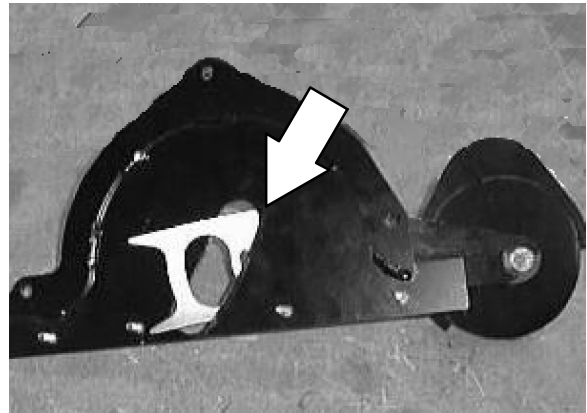

12. Reinstall the main brush idler mount plate. See TO REPLACE MAIN BRUSH instructions in this sections.

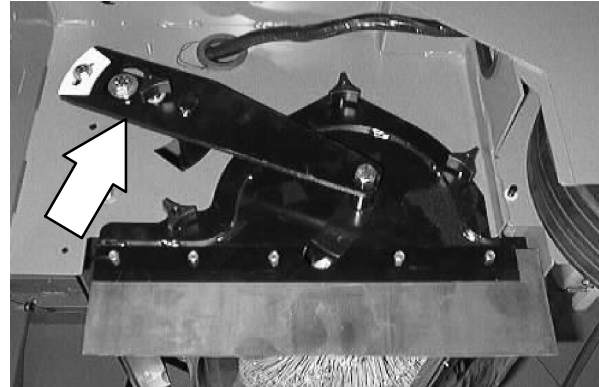

13. Close the left hand side brush door.

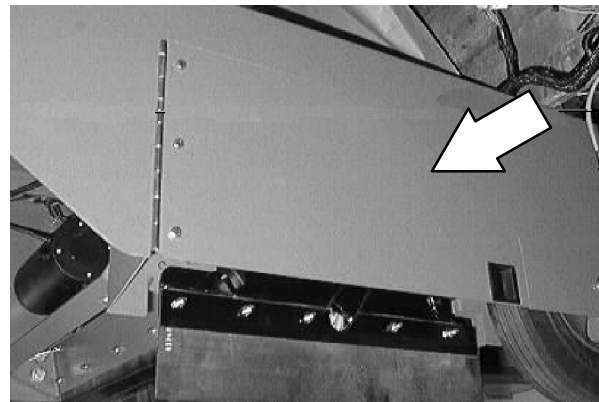

14. Operate the machine and check the main brush for proper operation.

TO REPLACE MAIN BRUSH DRIVE PLUG SHAFT BEARINGS

FOR SAFETY: Before Leaving Or Servicing Machine; Stop On Level Surface, Set Parking Brake.

1. Jack up the front of the machine at the jack points. Install jack stands under the machine frame.
2. Open the left hand side brush door. Remove the right hand brush door.
3. Remove the main brush idler mount plate. See TO REPLACE MAIN BRUSH instructions in this sections.

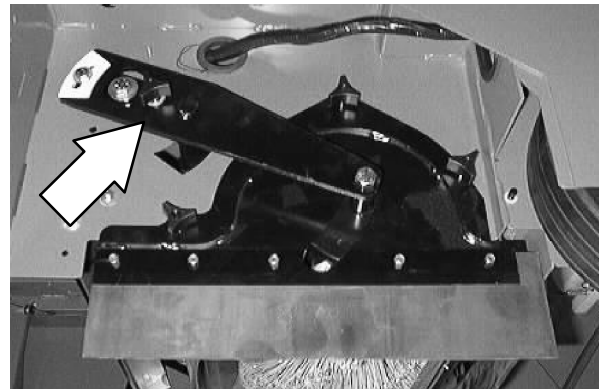
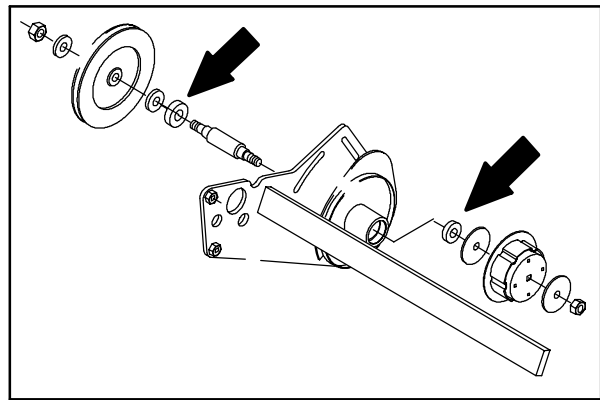

4. Remove the main brush. See TO REPLACE MAIN BRUSH instructions in this sections.

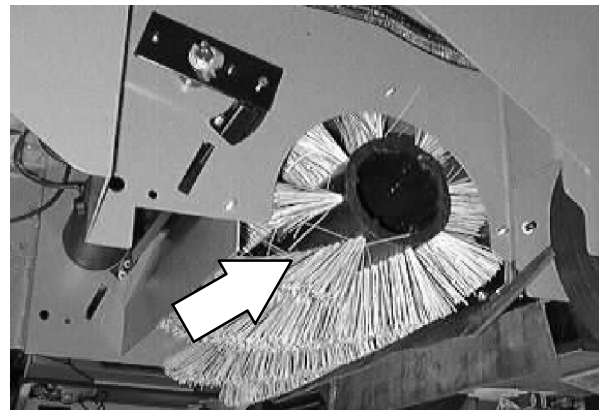

5. Remove the main brush drive belt. See TO REPLACE MAIN BRUSH DRIVE BELT instructions in this section.

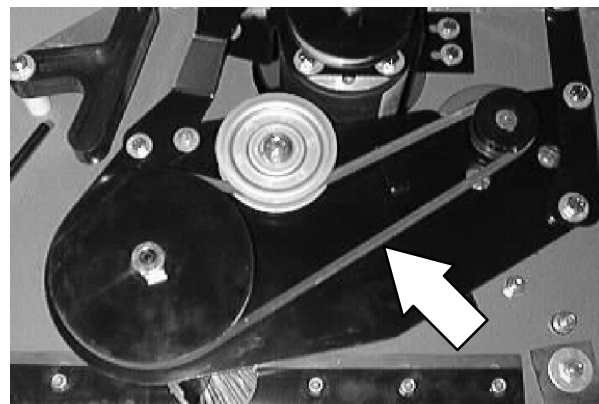

SWEEPING

6. Hold the main brush V-belt pulley (large one) from turning. Remove the large nut from the center of this pulley.

NOTE: This is a left hand thread nut.

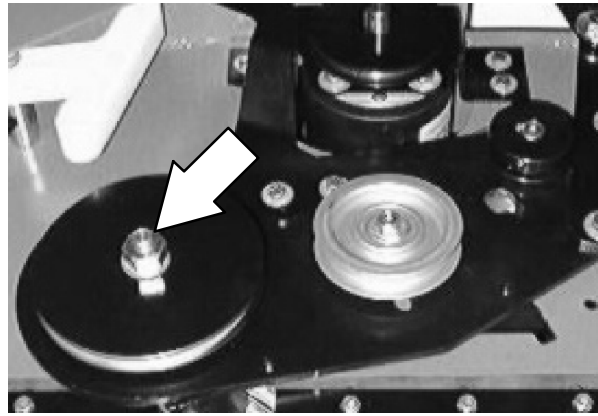

7. Remove the main brush V-belt pulley (larger one) from the main brush shaft. Make sure to retain the washer from behind the pulley.

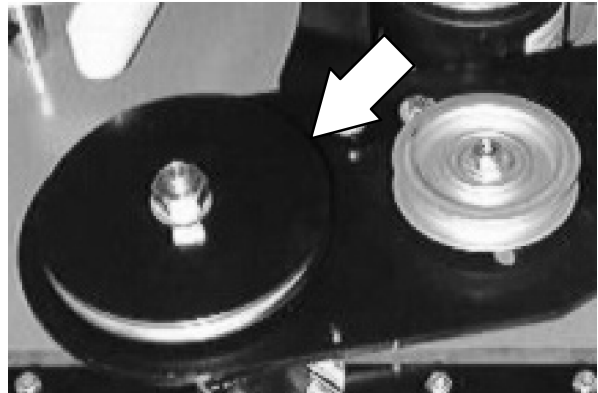

8. Hold the main brush drive plug from turning. Remove the large nut from the center of the drive plug.

NOTE: This is a left hand thread nut.

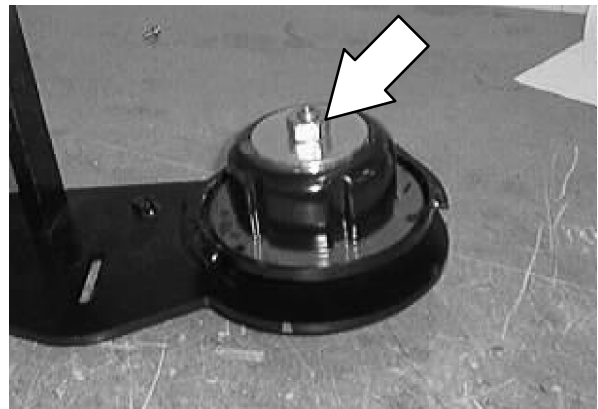

9. Remove the main brush idler plug assembly from the main brush shaft.

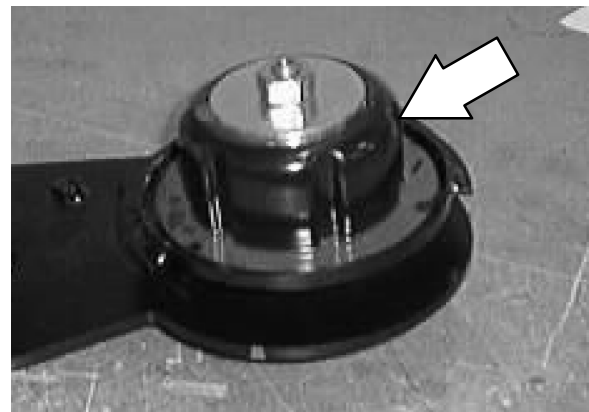

10. Reinstall the nut on the outside of the main brush shaft.
11. Use a hammer to lightly tap on the end of the shaft with the nut reinstalled. Tap on the shaft until the inner bearing is out of the housing.
12. Remove the nut from the main brush shaft. Remove the shaft and bearing from the machine.

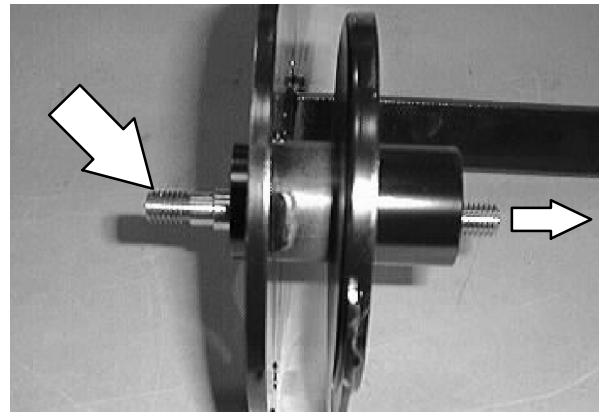

13. Use a long screw driver or punch to remove the remaining outer bearing from the main brush housing. Discard the bearing.
14. Use an arbor press to remove the bearing from the main brush shaft. Discard the bearing.
15. Install one new bearing onto the main brush shaft.

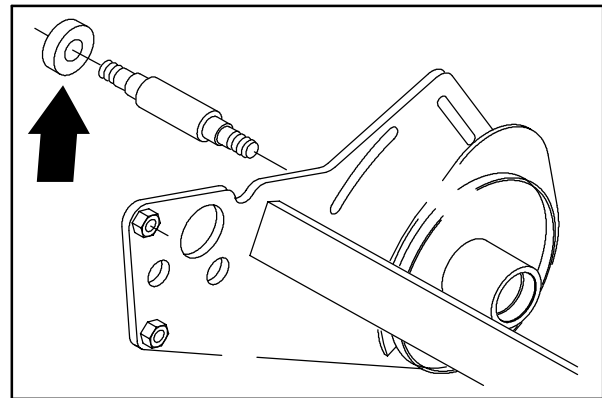

16. Install one new bearing into the outer side of the main brush bearing housing.

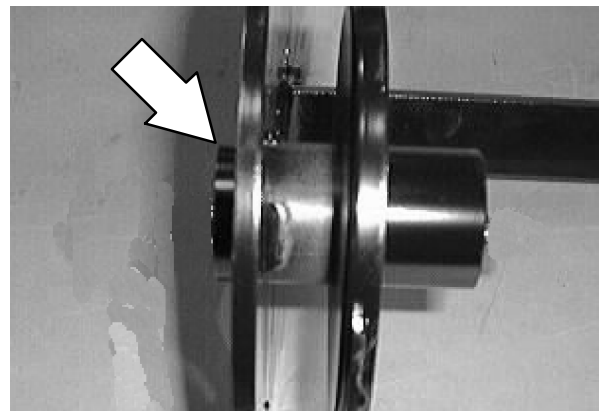

17. Install the new bearing and main brush shaft assembly into the main brush bearing housing. Install the nut onto the inside of the main brush shaft. Use a hammer to lightly tap the bearing and shaft into the housing.

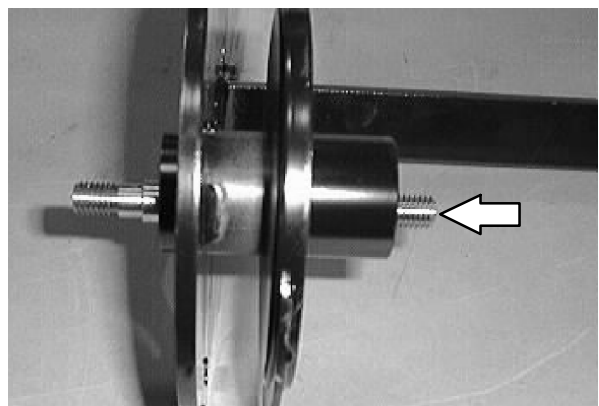

SWEEPING

18. Reinstall the main brush drive plug and washer onto the main brush shaft on the inside. Reinstall the left hand nut. Hand tighten tight.

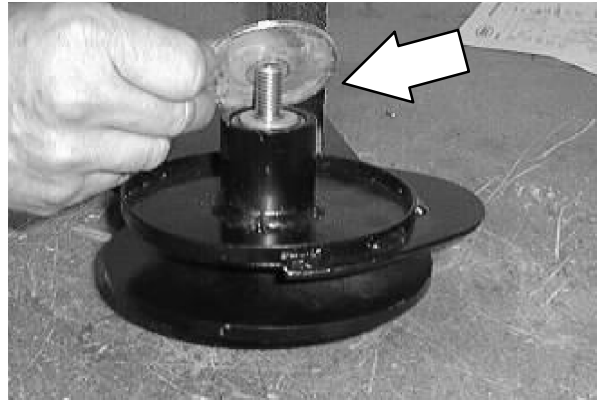

19. Reinstall the washer and V-belt pulley (*recess to inside*) onto the outside of the main brush shaft. Reinstall the left hand nut. Tighten to 52 - 67 Nm (39 - 51 ft lb).

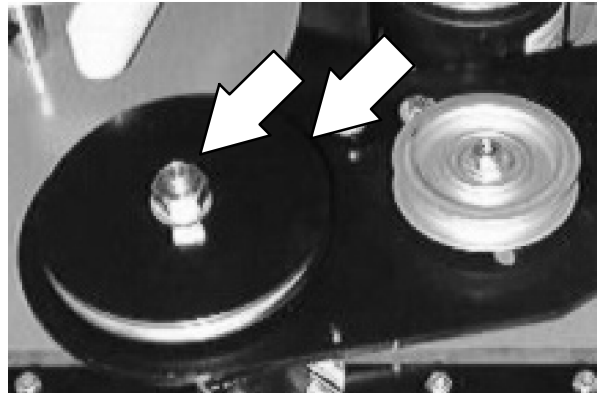

20. Reinstall the main brush drive belt. See TO REPLACE MAIN BRUSH DRIVE BELT instructions in this section.

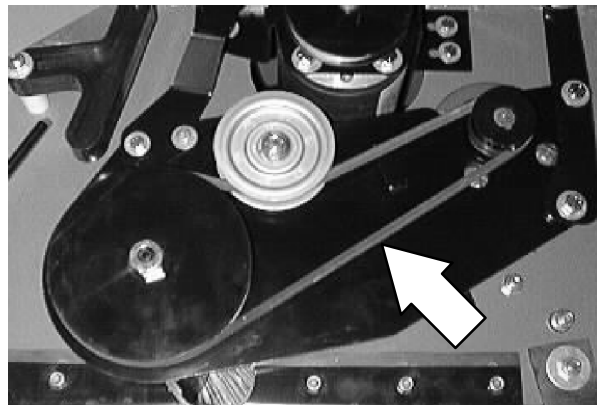

21. Reinstall the main brush. See TO REPLACE MAIN BRUSH instructions in this sections.

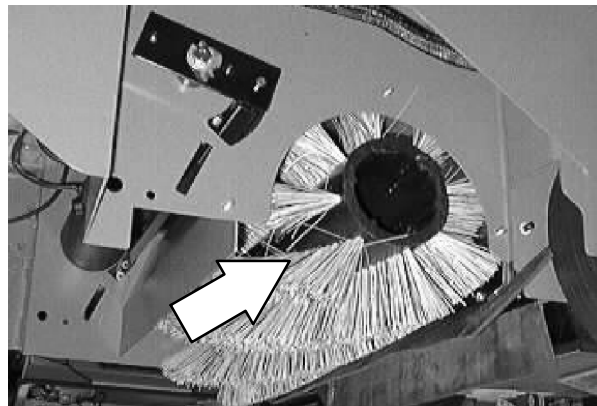

22. Reinstall the right hand brush door and close the left hand brush door.

23. Remove the jack stands and lower the machine.

24. Operate the machine and check the main brush for proper operation.

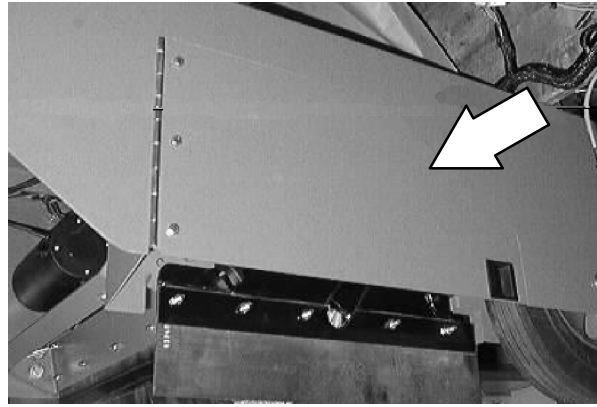

SWEEPING

TO REPLACE MAIN BRUSH DRIVE BELT IDLER PULLEY

FOR SAFETY: Before Leaving Or Servicing Machine; Stop On Level Surface, Set Parking Brake.

1. Remove the four screws holding the right hand brush door to the machine frame. Remove the right hand side brush door.
2. Locate the main brush drive belt idler pulley between the small motor drive pulley and the larger brush pulley.

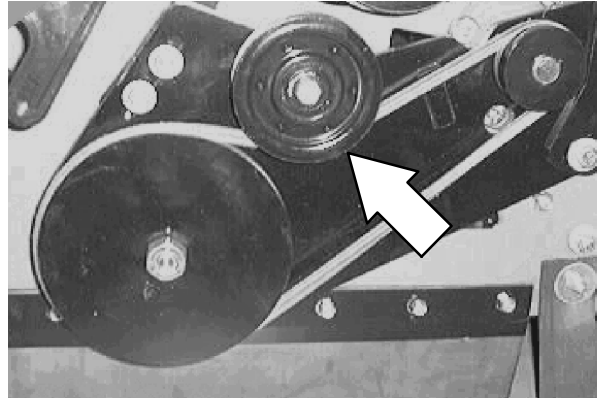

3. Loosen the hex nut in the center of the idler pulley.
4. Push the idler pulley back in the slot.

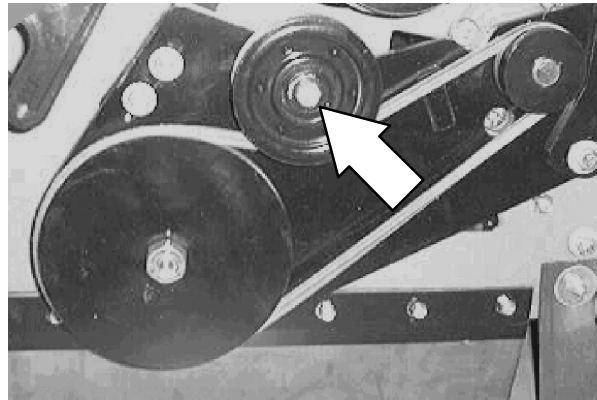

5. Remove the main brush drive belt from the two remaining pulleys.

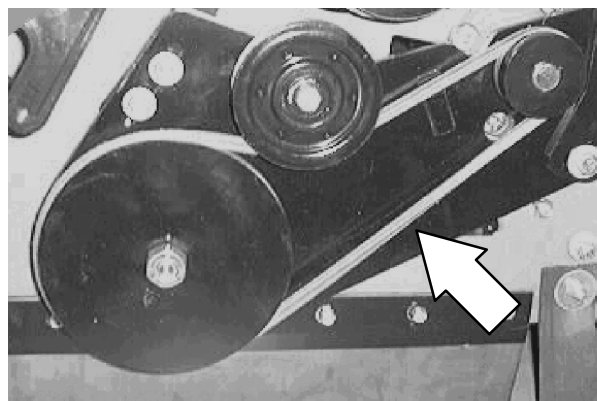

6. Remove the hex nut in the center of the idler pulley. Remove and discard the pulley.
7. Install the new idler pulley onto the hex bolt. Reinstall the hex nut. Leave loose for now.

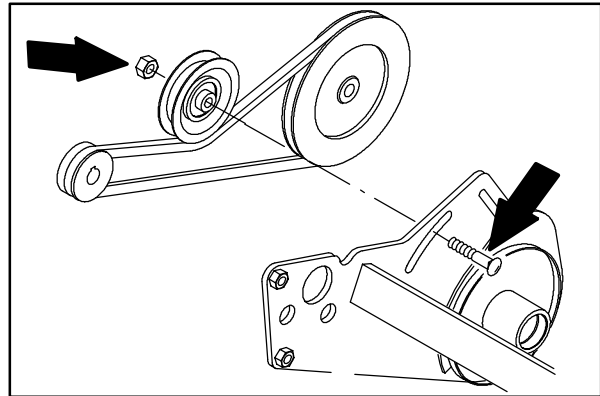

8. Reinstall the V-belt around the two drive pulleys and on top of the idler pulley.

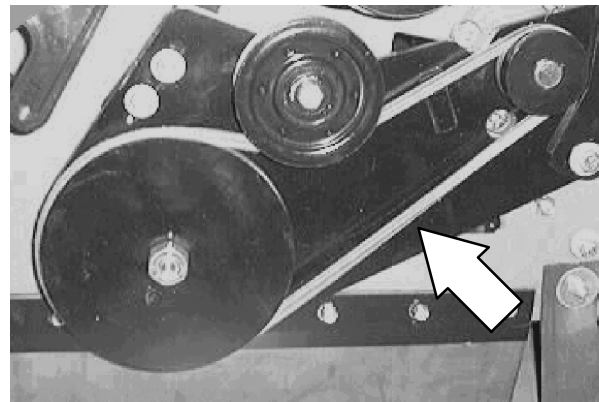

9. Pull down on the idler pulley until the belt is tight. Tighten the pulley nut to 18 - 24 Nm (15 - 20 ft lb).

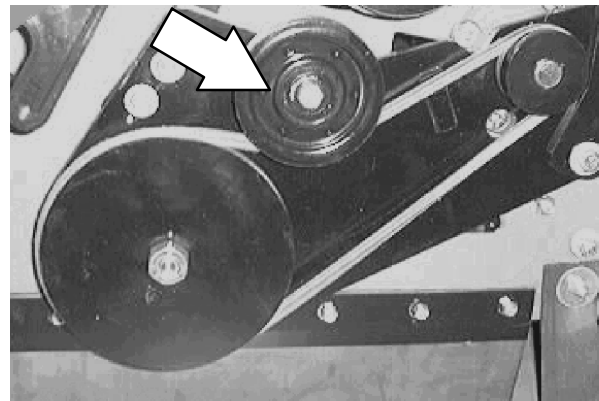

10. Reinstall the right hand side brush door.

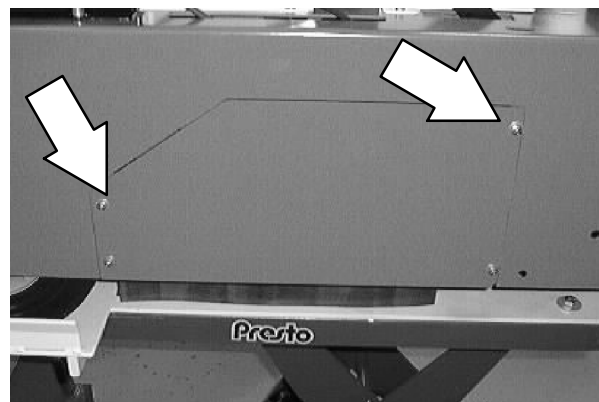

11. Operate the machine and check the main brush for proper operation.

SWEEPING

SIDE BRUSH

The side brush sweeps debris along edges into the path of the main brush.

Check the brush daily for wear or damage. Remove any string or wire found tangled on the side brush or side brush drive hub.

Check the side brush pattern daily. The side brush bristles should contact the floor in a 10 o'clock to 3 o'clock pattern when the brush is in motion. Adjust the side brush pattern by loosening the hex screw located above the side brush cable pulley in the front of the operators compartment. Move the pulley mount bracket up or down to achieve the proper side brush pattern. Retighten the hex screw.

The side brush should be replaced when it no longer sweeps effectively for your application. A guideline length is when the remaining bristles measure 50 mm (2 in) in length. You may need to replace the side brush sooner if you are sweeping light litter or use a brush with shorter bristles if you are sweeping heavy debris.

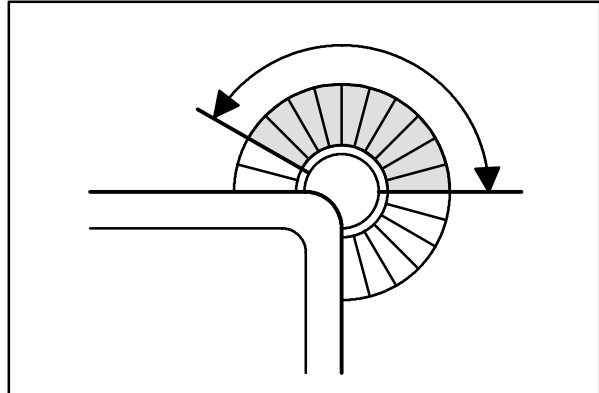

TO REPLACE SIDE BRUSH

1. Stop the machine, set the parking brake and turn the machine power off.

FOR SAFETY: Before Leaving Or Servicing Machine; Stop On Level Surface, Set Parking Brake.

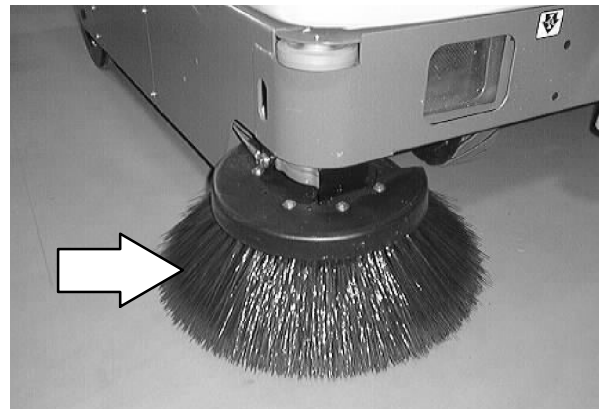

2. Remove the side brush retaining pin from the side brush drive shaft by pulling the pin keeper off over the end of the pin.

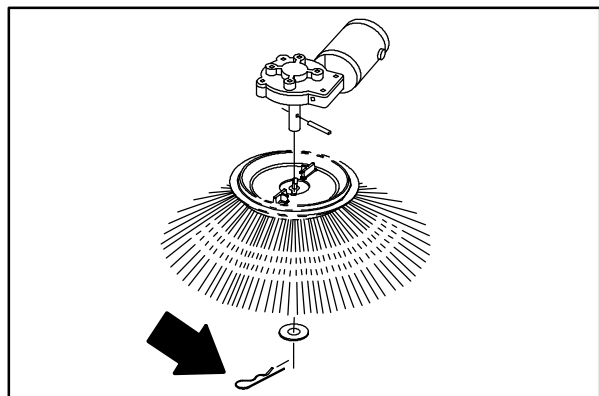

3. Slide the side brush off the side brush drive shaft.
4. Slide the new side brush onto the side brush drive shaft.

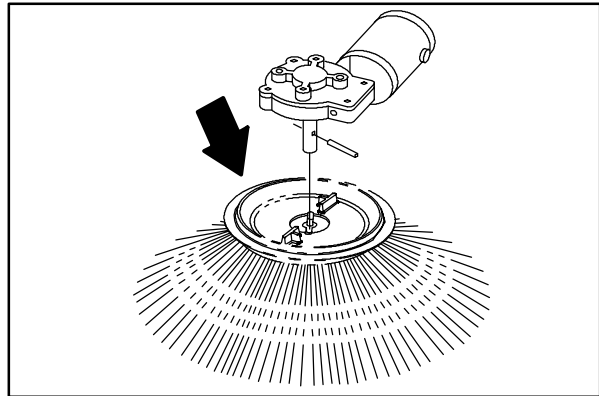

5. Insert the side brush retaining pin through the side brush hub and shaft.
6. Secure the pin by clipping the pin keeper over the end of the pin.

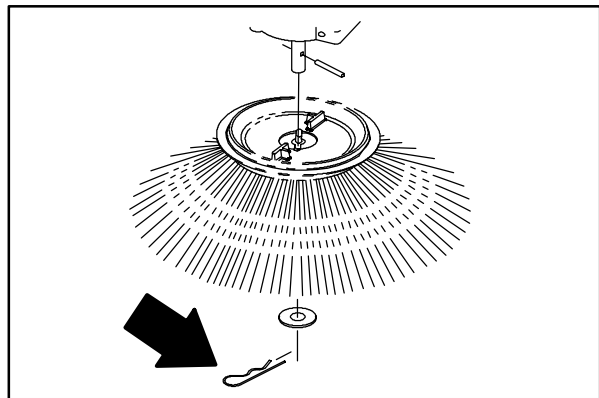

7. Adjust the side brush pattern by loosening the hex screw located above the side brush cable pulley in the front of the operators compartment. Move the pulley mount bracket up or down to achieve the proper side brush pattern. Retighten the hex screw.

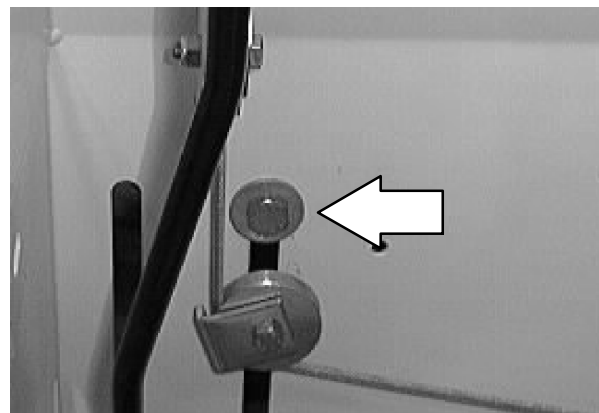

SWEEPING

SIDE BRUSH GUARD

Check the side brush guard after every 200 hours of operation. Replace the brush guard after it begins to show serious wear.

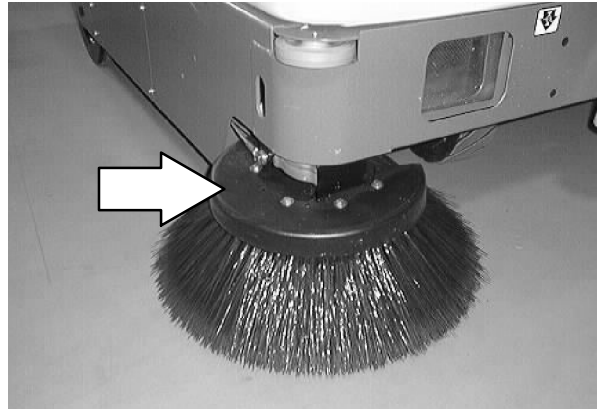

SIDE BRUSH PIVOT

The side brush pivot should be checked for excessive movement after every 200 hours of operation. Torque the front and rear compression springs to reduce excessive movement.

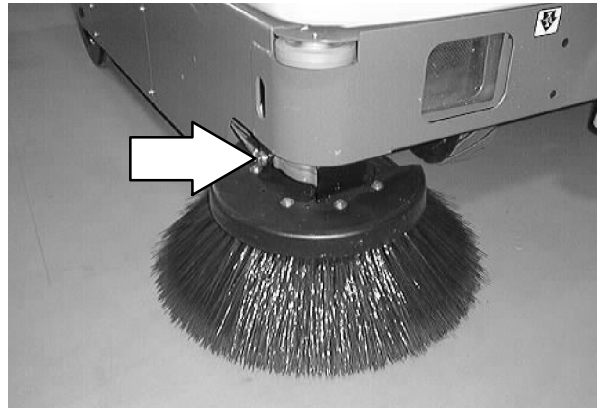

TO REPLACE SIDE BRUSH LIFT CABLE

FOR SAFETY: Before Leaving Or Servicing Machine; Stop On Level Surface, Set Parking Brake.

1. Lower the side brush handle.

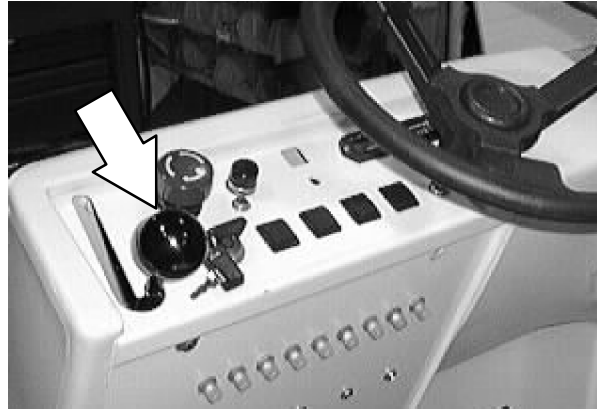

2. Go under the front of the machine near the side brush. Locate the side brush lift cable clevis under the brush pivot hex nut. Remove the nut only. Pull the side brush lift cable off the hex screw.

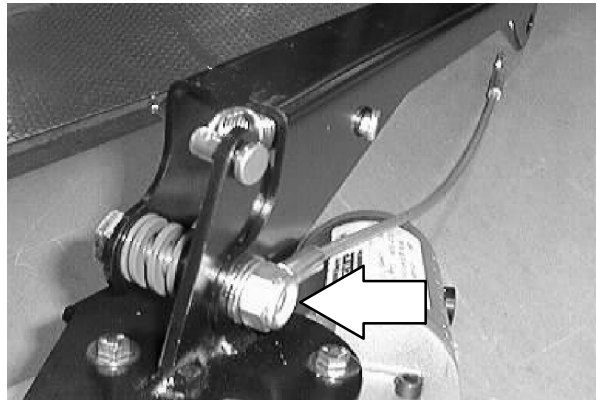

3. Go to the operators compartment. Remove the two cable pulleys, sleeves, and cable clips from the side brush lift cable.

NOTE: Note the orientation of the cable clips for proper re-assembly.

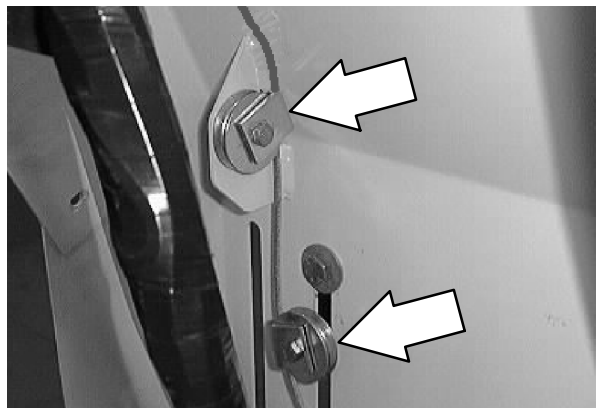

SWEEPING

4. Go to the front corner of the operators compartment and remove the cable pulley, sleeve, and cable clip from the side brush lift cable.

NOTE: Note the orientation of the cable clips for proper re-assembly.

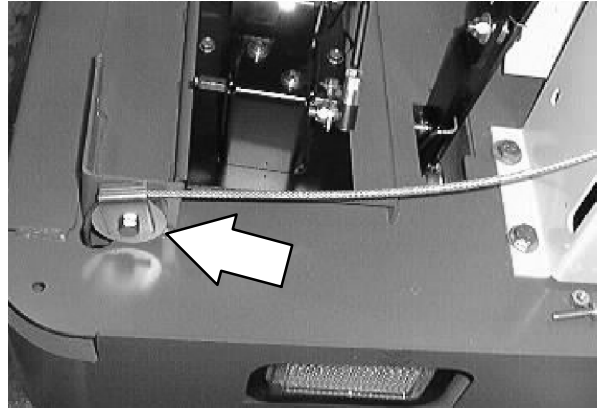

5. Go up under the instrument panel and remove the hex screw and nut holding the end of the side brush lift cable to the lift handle. Remove the side brush lift cable from the machine.

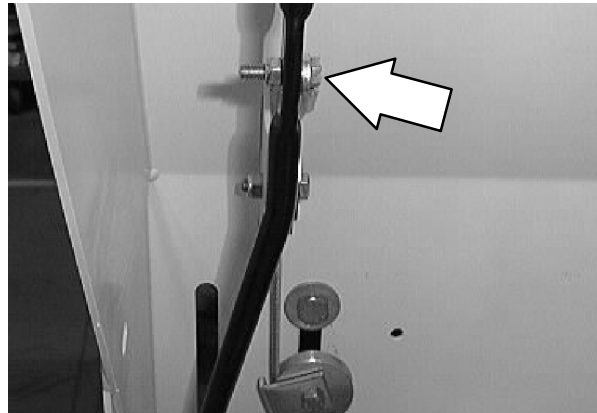

6. Route the new side brush lift cable in the machine.



7. Reinstall the three cable pulleys, sleeves, and cable clips. Make sure the cable clips are in the correct orientation. Tighten the hardware to 18 - 24 Nm (15 - 20 ft lb).

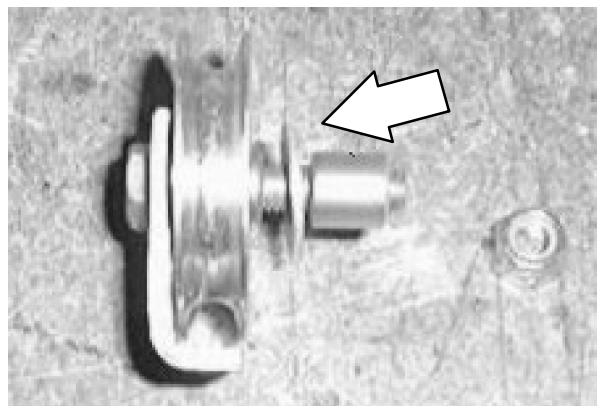

8. Connect the new side brush lift cable to the side brush pivot screw. Hand tighten the hex nut. Cable should pivot on the hardware.

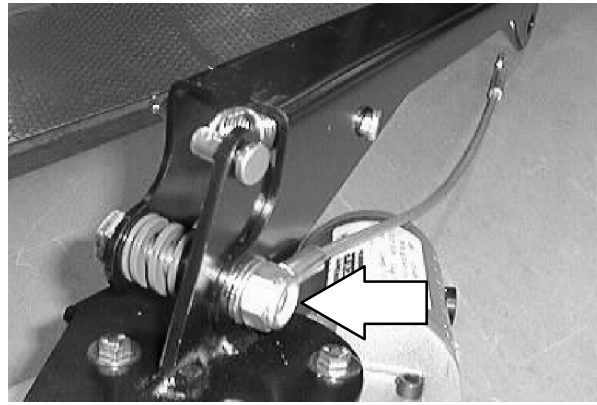

9. Connect the side brush lift cable to the lift handle.

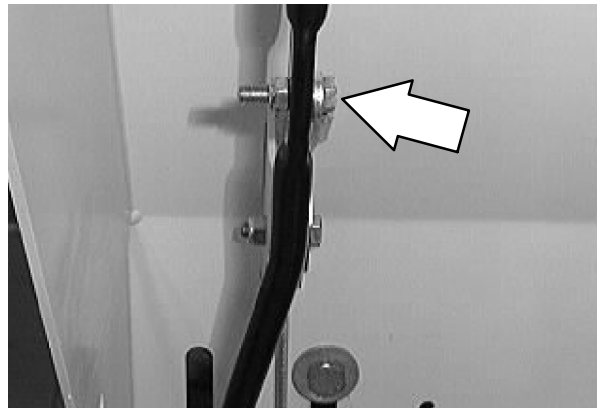

10. Raise the side brush. Check the new cable for smooth operation.

SKIRTS AND SEALS

REAR SKIRT

The two rear skirts are located on the bottom rear of the main brush compartment. The vertical skirt should clear the floor up to 2 mm (0.09 in). The recirculation skirt requires no adjustment.

Check the skirts for wear or damage and adjustment daily.

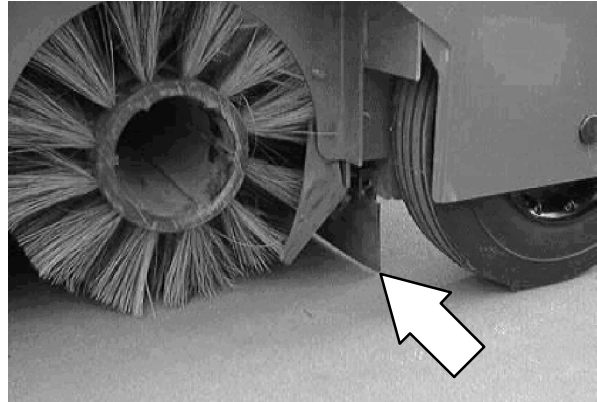

NOTE: The recirculation skirt must be folded in between the brush and the machine frame before the brush door is mounted on for the machine to work properly.

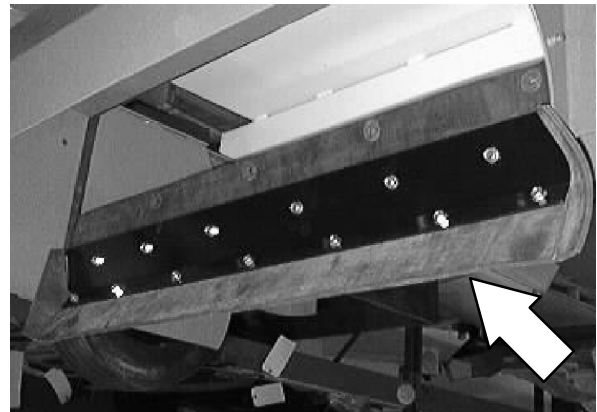

SIDE SKIRTS

The side skirts are located on both sides of the main brush compartment. The skirts should clear the floor up to 5 mm.

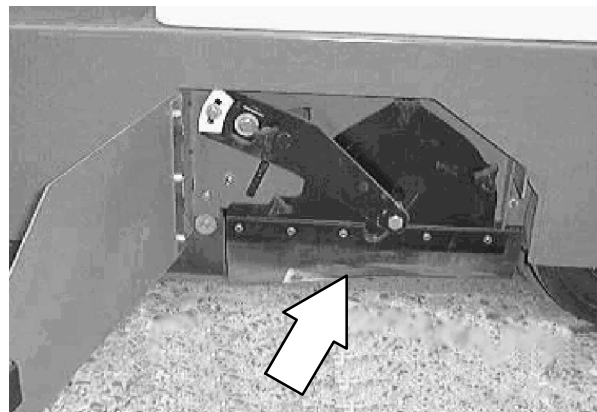

LARGE DEBRIS TRAP SKIRT

The large debris trap skirt is located along the front of the main brush. This skirt is raised and lowered by the large debris trap pedal, allowing larger debris to be trapped and swept up into the hopper.

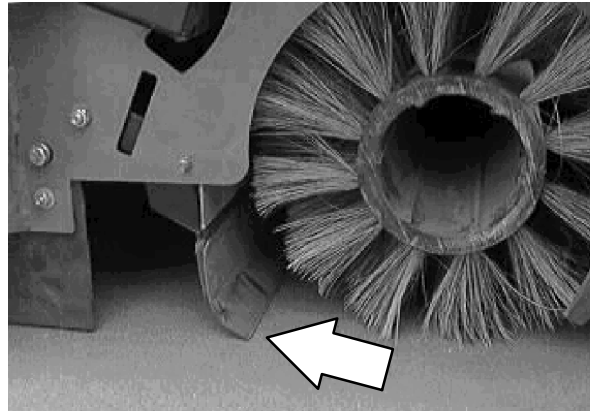

This skirt should be adjusted so it touches the floor and is curled back, toward the main brush (**curl back should be 3/4 inch \pm 1/8 inch**). Sweeping performance will be adversely affected if this skirt does not contact the floor.

Check the skirt for wear or damage after every 100 hours of operation.



HOPPER SEALS

The hopper seals are located around the edge of the opening between the main brush and the hopper. The hopper rests against the seals when the hopper is in the closed position.

Check the seals for wear or damage after every 100 hours of operation.

⚠ WARNING: Raised hopper may fall. Engage hopper support bar.

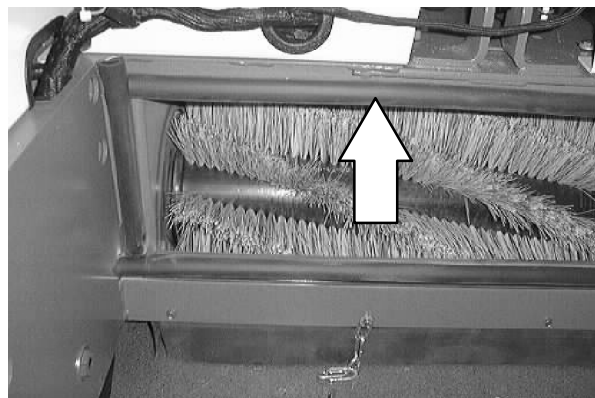

SWEEPING

HOPPER DOOR SEAL

The hopper door seal is located on the bottom of the hopper and seals the hopper door when the hopper door is closed.

Check the seal for wear or damage after every 100 hours of operation.

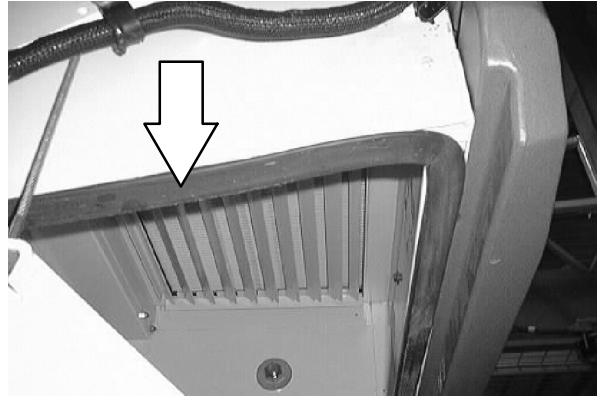

HOPPER LIP SEAL

The hopper lip seal is located on the inside of the rear lip of the hopper door and seals the inside lip of the hopper door with the hopper.

Check the seal for wear or damage after every 100 hours of operation.

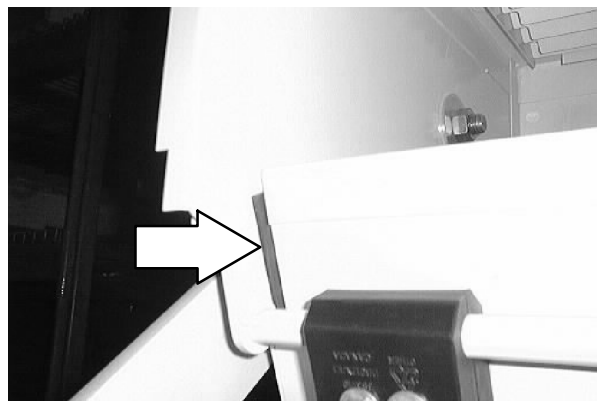

FRONT SKIRT

The front skirt is located along the front of the main brush. The front skirt can be raised with the foot pedal in the operators compartment. Raising the front skirt will allow large debris to enter the main brush area and be deposited into the hopper.

Check the seal for wear or damage after every 100 hours of operation.

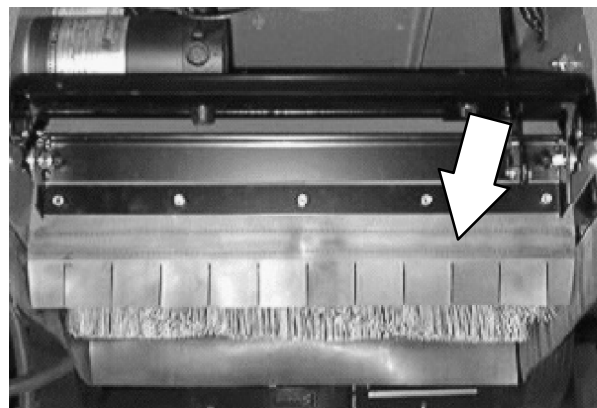

VACUUM FAN

The vacuum system pulls dust and air into the hopper through the Instant Access™ filter. The vacuum fan is powered by an electric motor and driven with a V-belt.

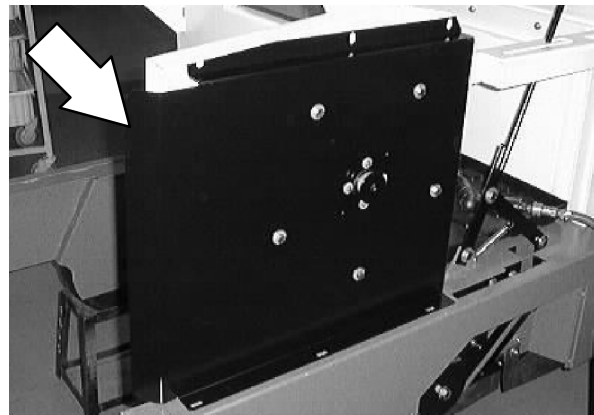

VACUUM FAN BELT

Check the vacuum fan belt tension and wear after every 100 hours of operation. The correct tension is when the belt deflects 13.0 mm (0.50 in) from a force of 17 kg (38 lb) at belt midpoint.

 **WARNING: Moving belt and fan. Keep away.**

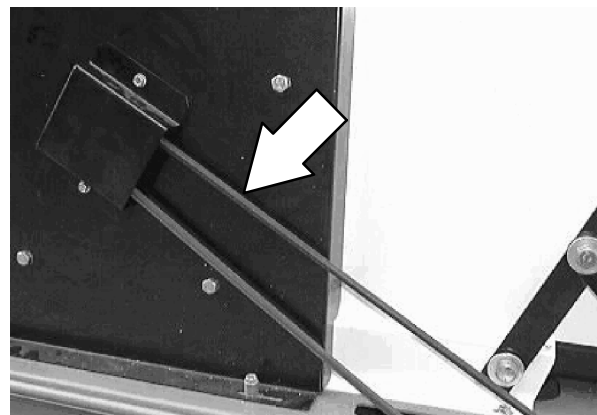

SWEEPING

TO REPLACE VACUUM FAN DRIVE BELT

FOR SAFETY: Before Leaving Or Servicing Machine; Stop On Level Surface, Set Parking Brake.

1. To access the vacuum fan drive belt, remove the right hand side panel. Start by lifting up on the panel, pop the brush lift slot over the black knob, then move the panel backward and off the machine.



2. Remove the right hand side brush door.

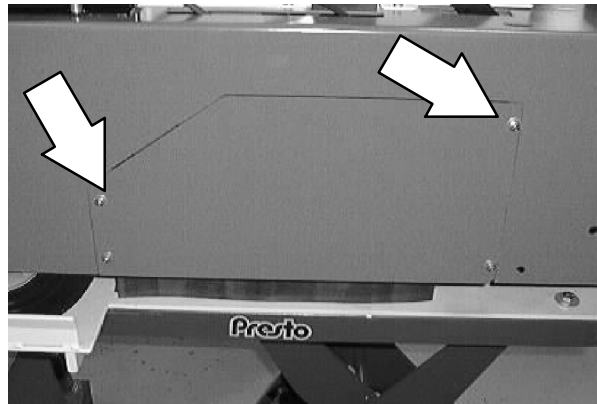

3. Loosen the five hex screws holding the vacuum fan housing to the machine frame.

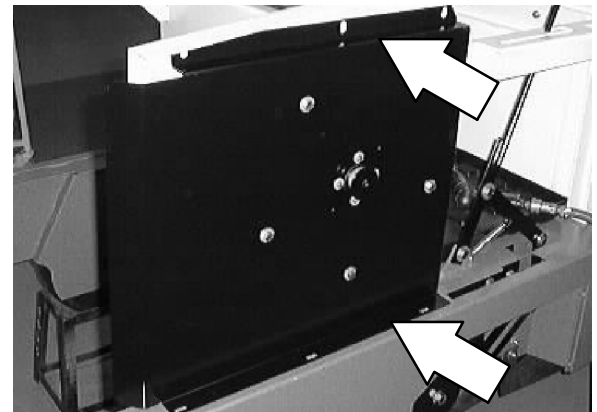

4. Push the vacuum fan assembly forward in the slots to loosen the vacuum fan V-belt.

5. Remove the two hex screws holding the cover over the V-belt pulley. Remove the cover.

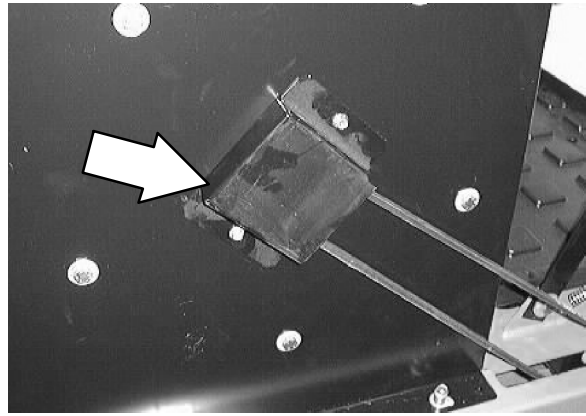

6. Remove the vacuum fan V-belt from the motor and impeller pulleys. Remove the old V-belt from the machine.
7. Install the new vacuum fan V-belt over both pulleys.

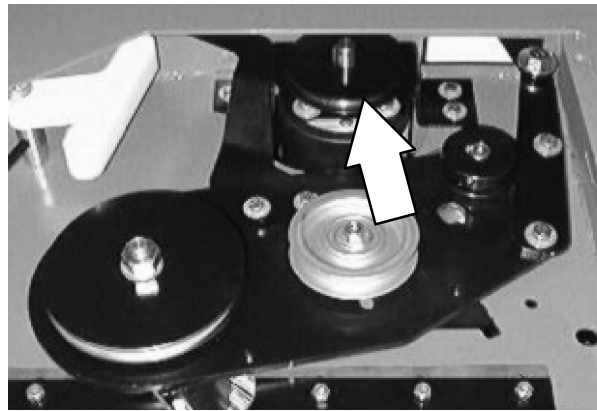

8. Pull the vacuum fan assembly toward the back of the machine to tighten the V-belt. Tighten the five mounts screws hand tight. The correct tension is when the belt deflects 13.0 mm (0.50 in) from a force of 17 kg (38 lb) at belt midpoint.

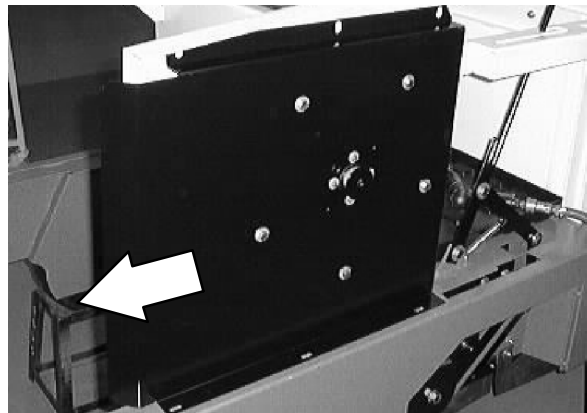

9. Reinstall the V-belt cover. Tighten the two screws hand tight.

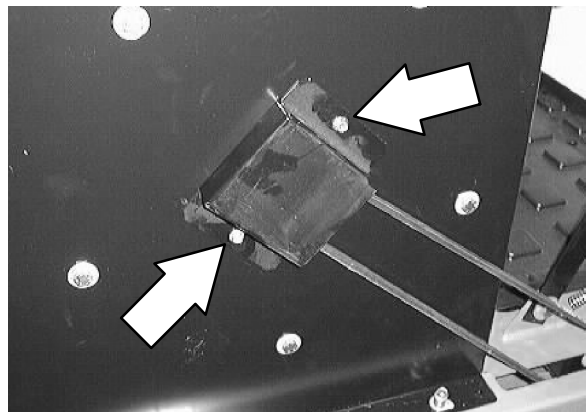

SWEEPING

10. Reinstall the right hand machine cover.



11. Reinstall the right hand brush door.

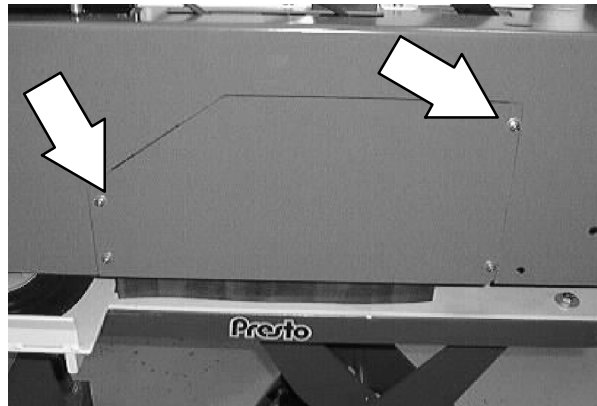

12. Operate the machine. Check the vacuum fan for proper operation.

TO ADJUST VACUUM FAN DRIVE BELT TENSION

FOR SAFETY: Before Leaving Or Servicing Machine; Stop On Level Surface, Set Parking Brake.

1. To access the vacuum fan drive belt, remove the right hand side panel. Start by lifting up on the panel, pop the brush lift slot over the black knob, then move the panel backward and off the machine.



2. Loosen the four hex screws holding the vacuum fan housing to the machine frame.

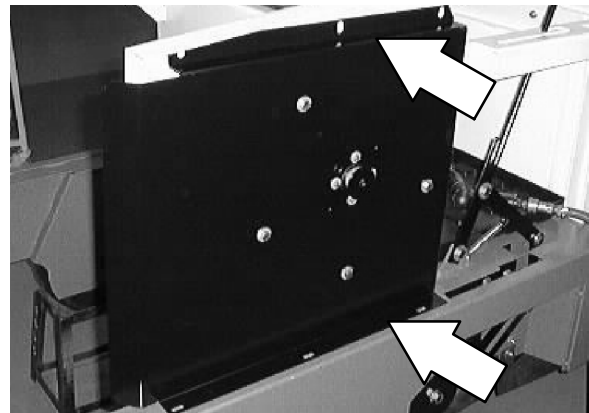

3. Pull the vacuum fan assembly toward the back of the machine to tighten the V-belt. The correct tension is when the belt deflects 13.0 mm (0.50 in) from a force of 17 kg (38 lb) at belt midpoint.
4. Tighten the four vacuum housing mount screws hand tight.
5. Reinstall the right hand machine cover.
6. Operate the machine. Check the vacuum fan for proper operation.

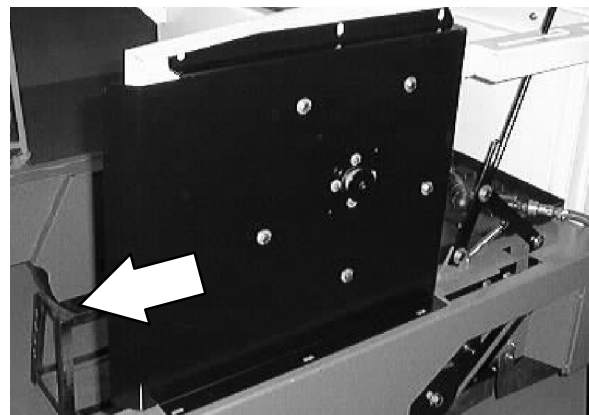

SWEEPING

TO REPLACE VACUUM FAN IMPELLER

1. Raise the hopper and engage the hopper up prop arm. Shut off the machine.

FOR SAFETY: Before Leaving Or Servicing Machine; Stop On Level Surface, Set Parking Brake.



2. To access the vacuum fan drive belt, remove the right hand side panel. Start by lifting up on the panel, pop the brush lift slot over the black knob, then move the panel backward and off the machine.



3. Loosen the five hex screws holding the vacuum fan housing to the machine frame.
4. Push the vacuum fan assembly forward in the slots to loosen the vacuum fan V-belt.

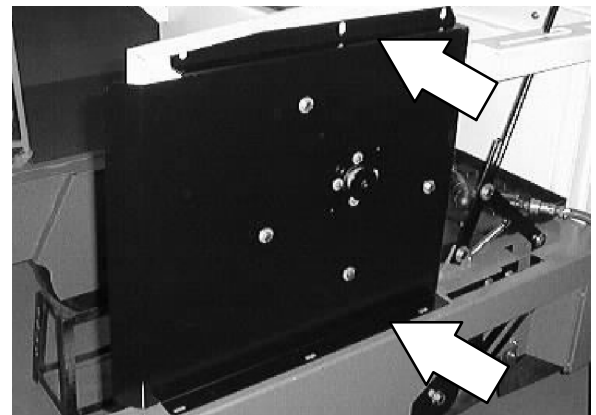

5. Remove the two hex screws holding the cover over the V-belt pulley. Remove the cover.
6. Remove the vacuum fan V-belt from the vacuum fan sheave.

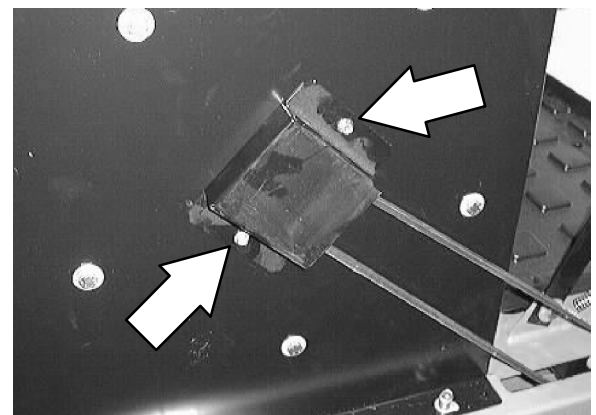

7. Disconnect the wires from the Thermo Sentry™.

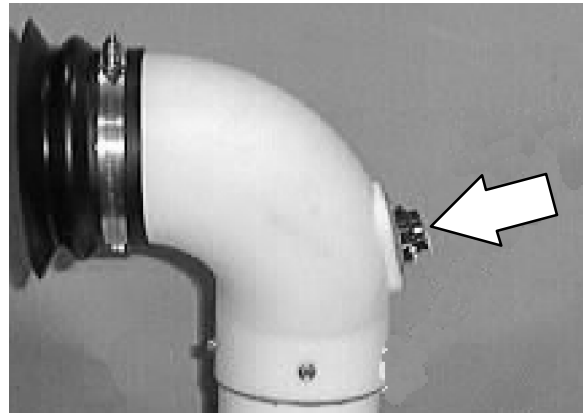

8. Remove the five hex nuts holding the vacuum fan assembly to the machine. Remove the assembly from the machine.

NOTE: Make sure to retain the two steel sleeves from the bottom two hex screws.

9. Place the assembly on a work bench with the vacuum fan inlet plate facing up.

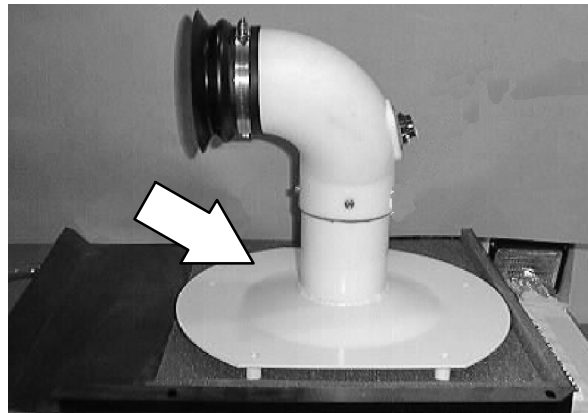

10. Remove the five hex screws and nuts holding the vacuum fan inlet plate to the bearing housing plate. Remove the inlet plate from the housing.

NOTE: Make sure to retain the five steel sleeves.

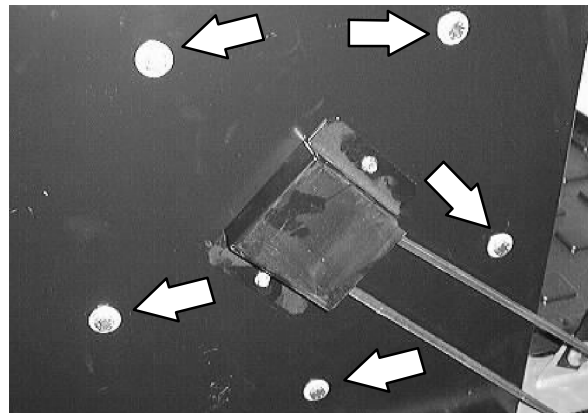

11. Remove the nyloc nut holding the vacuum fan impeller to the fan shaft. Pull the impeller off the shaft.

NOTE: Make sure to retain the square key.

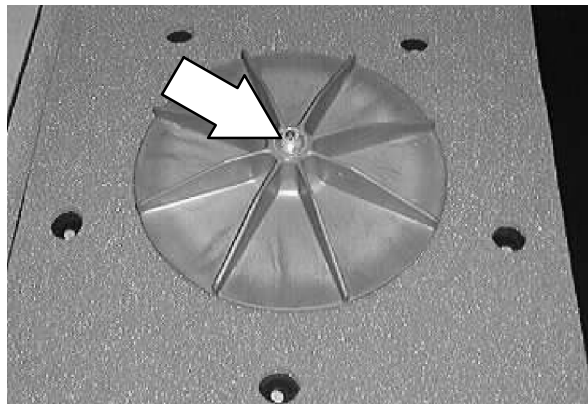

SWEEPING

12. Install the new vacuum fan impeller onto the fan shaft. Make sure to reinstall the square key on the fan shaft.
13. Reinstall the nyloc nut onto the fan shaft. Tighten to 11 - 14 Nm (7 - 10 ft lb).

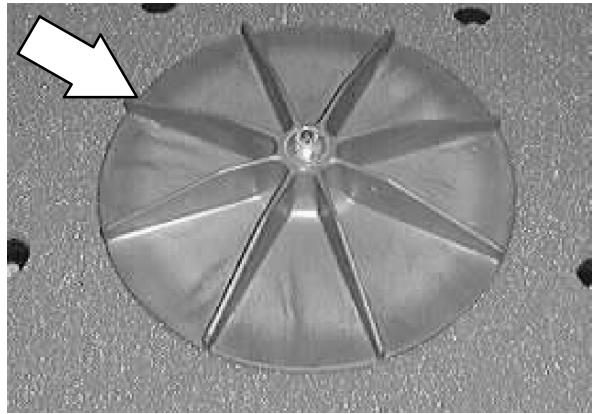

14. Reinstall the vacuum fan inlet plate onto the bearing housing plate. Reinstall the five steel sleeves, hex screws, and nuts. Center the hole in the plate over the impeller fins. Tighten the hardware to 18 - 24 Nm (15 - 20 ft lb).

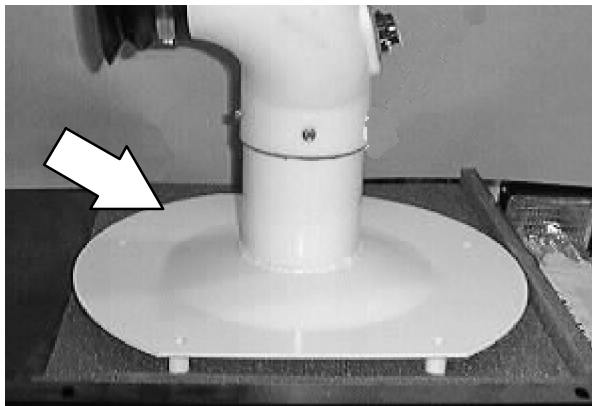

15. Position the vacuum fan assembly onto the right side off the machine. Reinstall the five hex screws and nuts. Make sure to install the two steel sleeves on the bottom two hex screws. Leave the hardware loose for now.

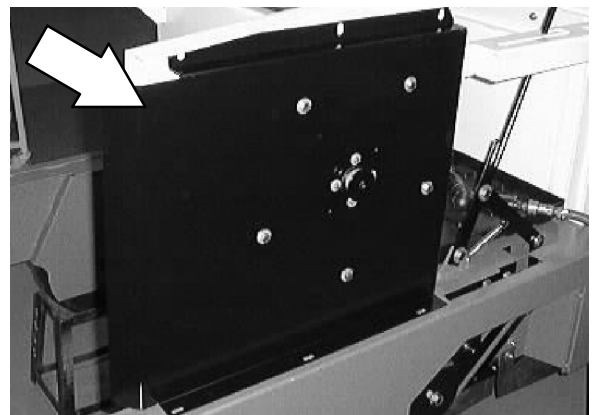

16. Install the vacuum fan V-belt over the fan sheave.

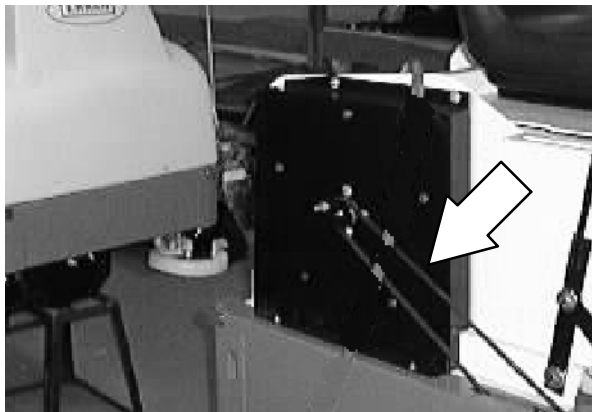

17. Pull the vacuum fan assembly toward the back of the machine to tighten the V-belt. The correct tension is when the belt deflects 8.38 mm (0.33 in) from a force of .42 kg (.90 to .95 lb) at belt midpoint.
18. Tighten the five mounts screws hand tight.

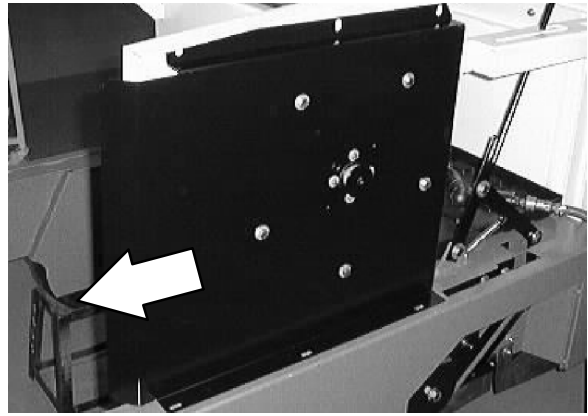

19. Reinstall the V-belt cover. Tighten the two screws hand tight.

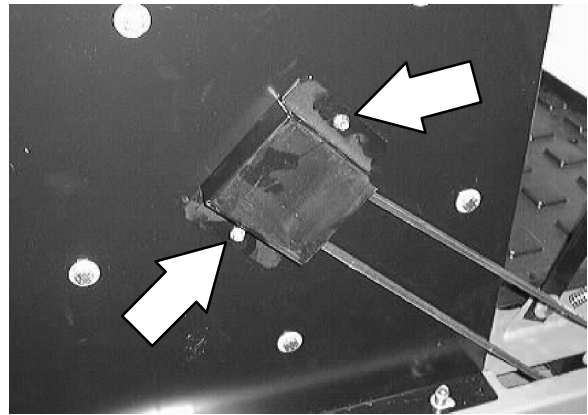

20. Connect the wires to the Thermo Sentry™.

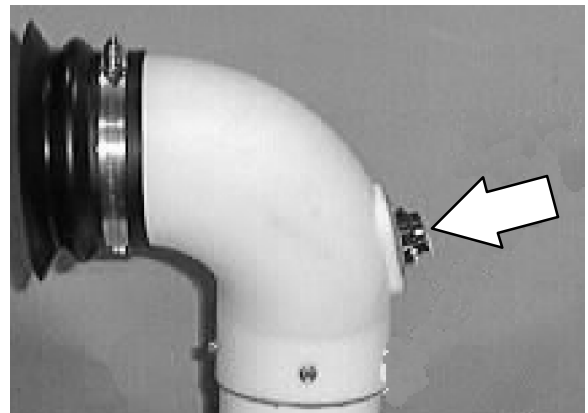

21. Reinstall the right hand machine cover.



SWEEPING

22. Start the machine, raise the hopper, disengage the prop arm. Lower the hopper.

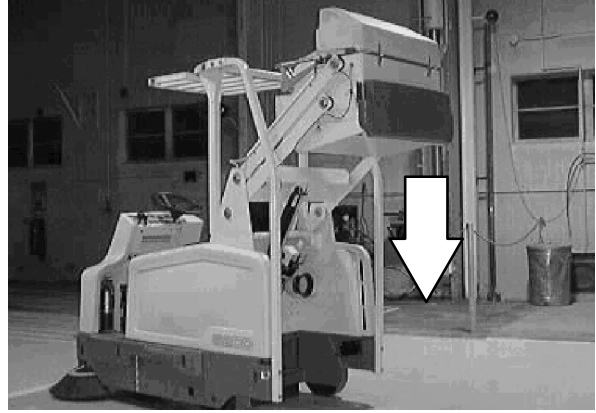

23. Operate the machine. Check the vacuum fan for proper operation.

TO REPLACE VACUUM FAN IMPELLER BEARINGS

FOR SAFETY: Before Leaving Or Servicing Machine; Stop On Level Surface, Set Parking Brake.

1. See TO REMOVE VACUUM FAN IMPELLER instructions to remove the vacuum fan assembly from the machine and and the impeller from the housing.

NOTE: Once the vacuum fan impeller has been removed, go to step 2.

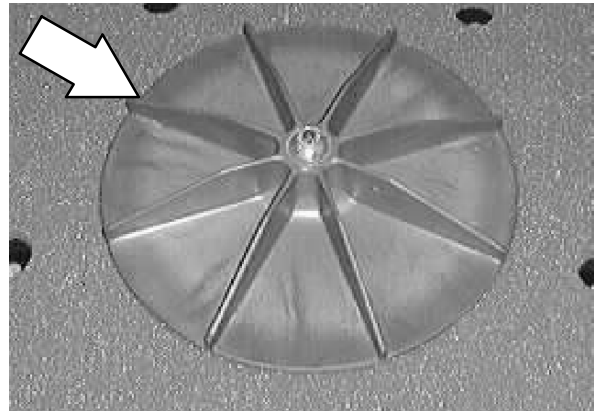

2. Loosen the two set screws holding the V-belt pulley to the fan shaft. Remove the pulley.

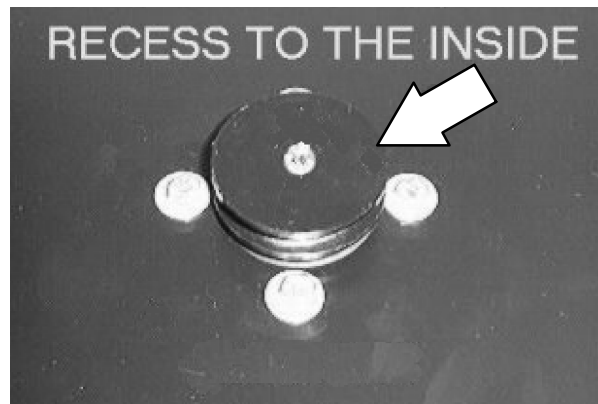

3. Remove the four hex screws holding the vacuum fan bearing assembly to the bearing plate. Remove the bearing assembly.

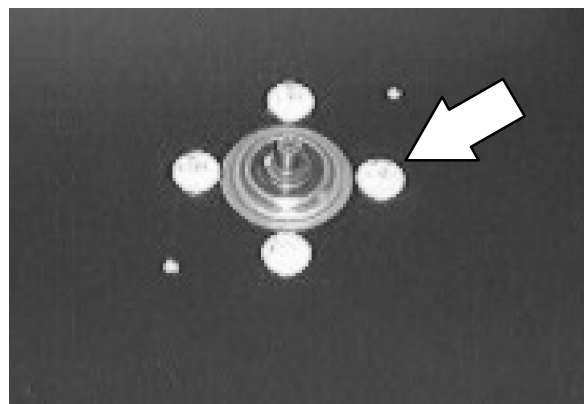

SWEEPING

4. Use an arbor press to remove the fan shaft and two bearings from the housing.

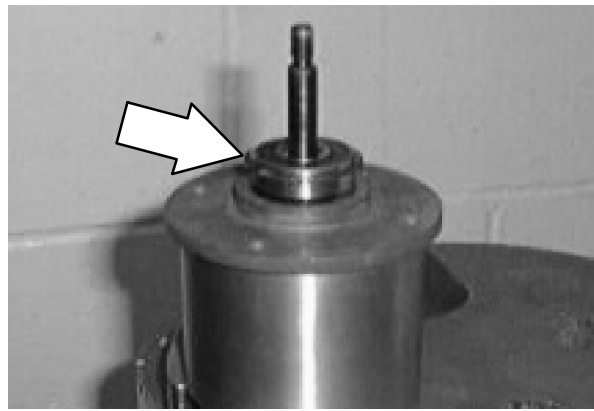

5. Use the arbor press to install the new bearings into the housing.

NOTE: The short end of fan shaft is on the side of housing with the thin flange. The long end of fan shaft is on the side of the housing with the wide flange.

NOTE: Make sure the bearings are pressed down tight. The fan will be noisy if there is any play in the bearings. The retaining rings must be tight to the housing.



6. Reinstall the bearing housing onto the bearing housing plate. The long end of the shaft is on the side with the sound foam. Reinstall the four hex screws and washers. Tighten to 8 - 10 Nm (6 - 8 ft lb).

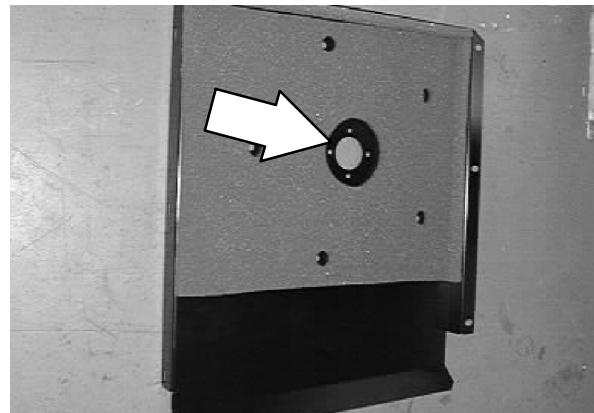

7. Reinstall the V-belt pulley on the short end of the fan shaft. *The recessed side of the pulley goes to the inside.* Hand tighten the set screws tight.

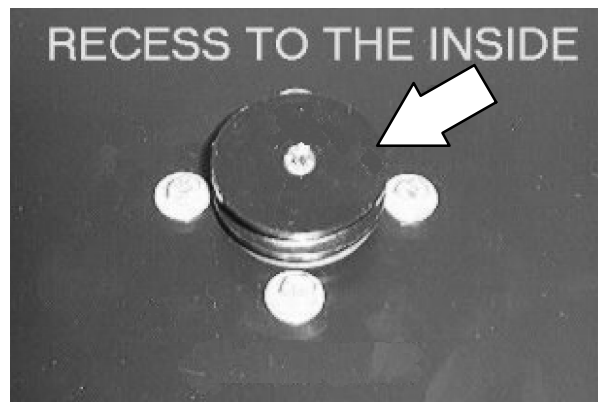

8. Reinstall the vacuum fan impeller onto the fan shaft. Make sure to reinstall the square key on the fan shaft.

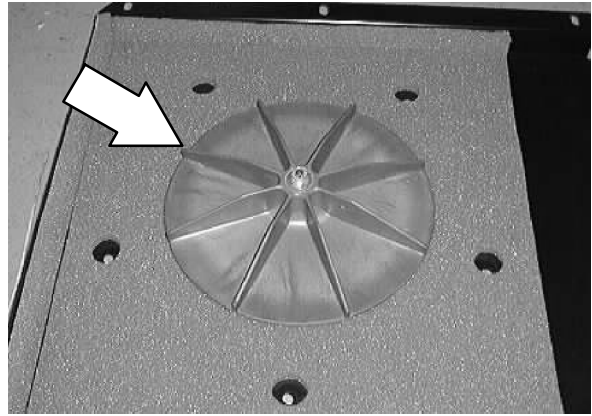

9. See TO REMOVE VACUUM FAN IMPELLER instructions to install the vacuum fan impeller and the vacuum fan assembly into the machine.

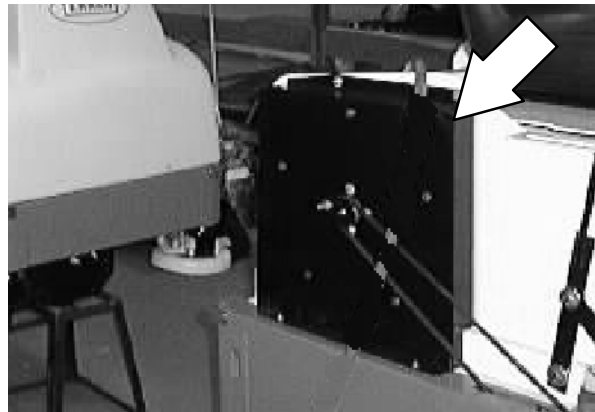

SWEEPING

MACHINE TROUBLESHOOTING

Problem	Cause	Remedy
No machine power	Power kill switch on	Turn kill switch clockwise until it pops up. Turn machine off and on
	Hopper dust filter clogged	Shake and or clean or replace dust filter
Low machine power	Low battery power	Check and charge batteries
Machine does not propel	Operator not in seat	Sit in operator seat
Excessive dusting	Vacuum fan off	Press the main brush, vacuum and filter shaker switch to the on position
	Brush skirts and dust seals worn, damaged, out of adjustment	Replace or adjust brush skirts or dust seals
	Hopper dust filter clogged	Shake and/or clean or replace dust filter
	Vacuum fan failure	Contact Tennant service personnel
	Thermo Sentry™ tripped	Reset Thermo Sentry™
	Hopper door partially or completely closed	Open hopper door
Poor sweeping performance	Brush bristles worn	Replace brushes
	Main and side brushes not adjusted properly	Adjust main and side brushes
	Debris caught in main brush drive mechanism	Remove debris from drive mechanism
	Main brush drive failure	Contact Tennant service personnel
	Side brush drive failure	Contact Tennant service personnel
	Hopper full	Empty hopper
	Hopper lip skirts worn or damaged	Replace lip skirts
	Wrong sweeping brush	Contact Tennant representative for recommendations
	Large debris trap damaged	Repair or replace large debris trap
	Hopper dust filter clogged	Shake and/or clean or replace dust filter
	Hopper door partially or completely closed	Open the hopper door
	Recirculation flap damaged	Replace flap

CONTENTS

	Page
INTRODUCTION	4-3
ELECTRICAL SYSTEM	4-4
BATTERIES	4-4
TO CHARGE BATTERIES	4-5
TO REPLACE BATTERIES	4-8
INSTRUMENT PANEL	4-12
TO ACCESS CIRCUIT BREAKER OR INSTRUMENT PANEL	4-12
TO REPLACE CIRCUIT BREAKER ..	4-15
TO REPLACE 80 AMP FUSE	4-18
FUSE	4-20
CIRCUIT BREAKERS	4-21
TO REPLACE PROPEL CONTROLLER	4-22
DIRECTIONAL PEDAL	4-24
TO REMOVE DIRECTIONAL PEDAL ASSEMBLY	4-24
TO INSTALL DIRECTIONAL PEDAL ASSEMBLY	4-26
TO REPLACE DIRECTIONAL CONTROL UNIT	4-28
ELECTRIC MOTORS	4-30
TO REPLACE FRONT DRIVE WHEEL MOTOR	4-30
TO REPLACE MAIN BRUSH MOTOR	4-32
TO REPLACE VACUUM FAN MOTOR	4-37
TO REPLACE SIDE BRUSH MOTOR	4-42
TO REPLACE DUMP DOOR ACTUATOR	4-45
THERMO SENTRY™	4-48
TO REPLACE THERMO SENTRY™ ..	4-49
ELECTRICAL SCHEMATIC (000000-002089)	4-52
ELECTRICAL SCHEMATIC (002090-)	4-54
MAIN WIRE HARNESS GROUP	4-56
HOPPER WIRE HARNESS GROUP	4-61
TROUBLESHOOTING	4-63
MACHINE START	4-64
PROPEL MOTOR CIRCUIT	4-68
PROPEL MOTOR CONTROLLER DIAGNOSTICS AND TROUBLESHOOTING GUIDE ...	4-74
MAIN SWEEPING BRUSH	4-75
VACUUM FAN MOTOR	4-78
FILTER SHAKER	4-81

INTRODUCTION

The 6200E electrical system consists of the batteries, instrument panel, drive motor, switches, relays, and circuit breakers.

ELECTRICAL SYSTEM

The model 6200E is a battery powered, all electric machine. The batteries are used to power the front drive motor, vacuum fan motor, main brush motor, side brush motor, and the filter shaker.

BATTERIES

The batteries are unique in that they hold their power for long periods of time. The lifetime of the batteries is limited by the number of charges the batteries receive. To get the most life from the batteries, charge them when the last battery discharge indicator segment flashes (20% charge left). Use an automatic charger with the proper rating for the batteries.

Periodically clean the top surface of the batteries and the terminals, and check for loose connections. Use a strong solution of baking soda and water. Brush the solution sparingly over the battery tops, terminals, and cable clamps. Do not allow any baking soda solution to enter the batteries. Use a wire brush to clean the terminal posts and the cable connectors. After cleaning, apply a coating of clear battery post protectant to the terminals and the cable connectors. Keep the tops of the batteries clean and dry.

Keep all metallic objects off the top of the batteries, which may cause a short circuit. Replace any worn or damaged wires.

Check the electrolyte level in each battery cell before and after charging, and after every 50 hours of operation. Do not charge the batteries unless the fluid is slightly above the battery plates. If needed, add just enough distilled water to cover the plates. Never add acid to the batteries. Do not overfill. Always keep the battery caps on, except when adding water or taking hydrometer readings.

Measuring the specific gravity, using a hydrometer, is a way to determine the charge level and condition of the batteries. If one or more of the battery cells test lower than the other battery cells (0.050 or more), the cell is damaged, shorted, or is about to fail.

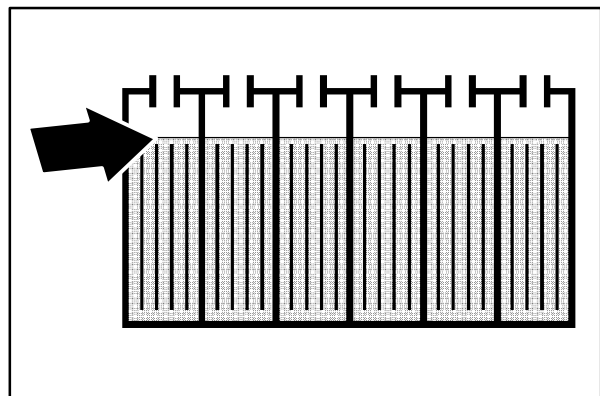

NOTE: Do not take readings immediately after adding distilled water. If the water and acid are not thoroughly mixed, the readings may not be accurate. Check the hydrometer readings against the following chart to determine the remaining battery charge level:

Spec. Gravity at 27° C (80° F)	
Charge Level	235 AH Battery
100 %	1.265
75 %	1.223
50 %	1.185
25 %	1.148
Discharged	1.110

NOTE: If the readings are taken when the battery electrolyte is any temperature other than shown, the reading must be temperature corrected. Add or subtract to the specific gravity reading 0.004, 4 points, for each 6° C (10° F) above or below 25° C (77° F).

TO CHARGE BATTERIES

1. Drive the machine to a flat, dry surface in a well-ventilated area.
2. Stop the machine, set the parking brake and turn the machine power off.

FOR SAFETY: Before leaving or servicing machine, stop on level surface, set parking brake, turn off machine, and remove key.

3. Open the seat support.
4. Check the water level in all the battery cells.

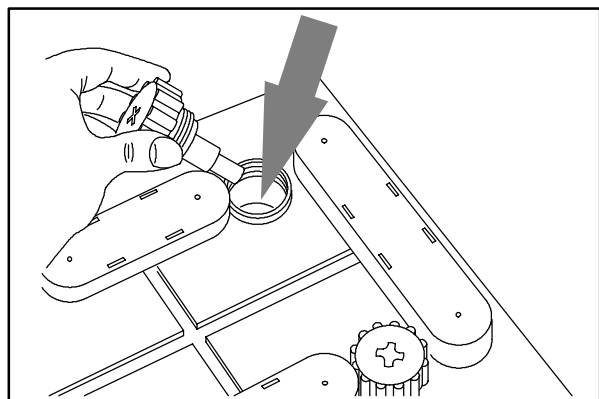

08247

ELECTRICAL

5. If the level is low, add just enough distilled water to cover the plates. DO NOT OVERFILL. The batteries can overflow during charging due to expansion.

NOTE: Make sure the battery caps are in place while charging.

FOR SAFETY: When maintaining or servicing machine, avoid contact with battery acid.

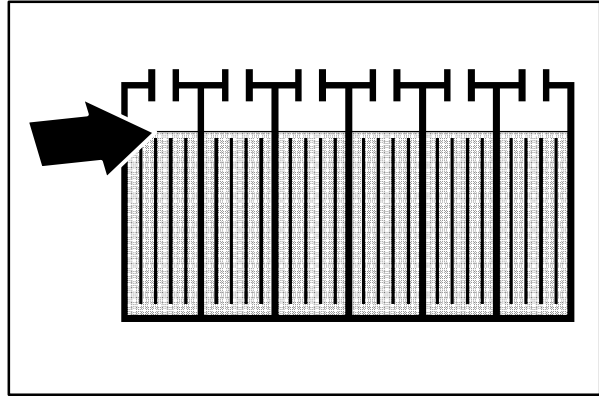

6. Unplug the battery connector from the machine connector.

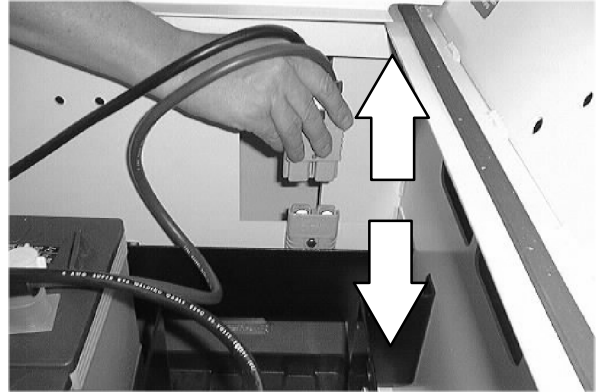

7. Plug the connector from the batteries into the battery charger connector.

⚠ WARNING: Batteries emit hydrogen gas. Explosion or fire can result. Keep sparks and open flame away. Keep covers open when charging.

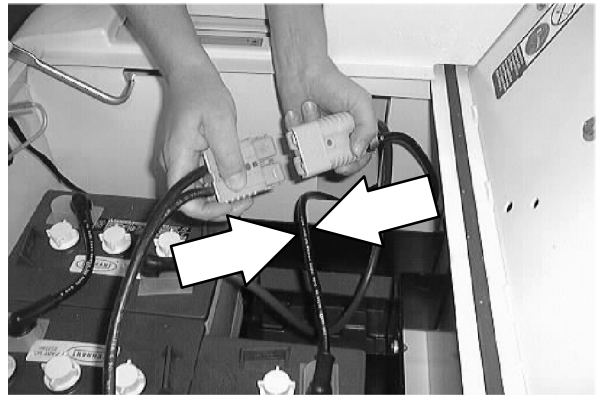

NOTE: Plug the charger connector into connector that runs to the batteries. Do not plug charger into mounted connector. Damage may occur to the machine.

NOTE: If the red "ABNORMAL CYCLE" lamp lights when the batteries are plugged into the TENNANT charger, this indicates that something is wrong with the battery. The charger can not charge the battery when this happens.



- The Tennant charger will start automatically. When the batteries are fully charged, the Tennant charger will automatically turn off.

NOTE: Use a charger with the proper rating for the batteries to prevent damage to the batteries or reduce the battery life.

NOTE: If the charger needs to be disconnected from the machine before the batteries are fully charged and the charger has not automatically shut off, turn off the charger before disconnecting.

- After the charger has turned off, unplug the charger connector from the battery connector on the machine.

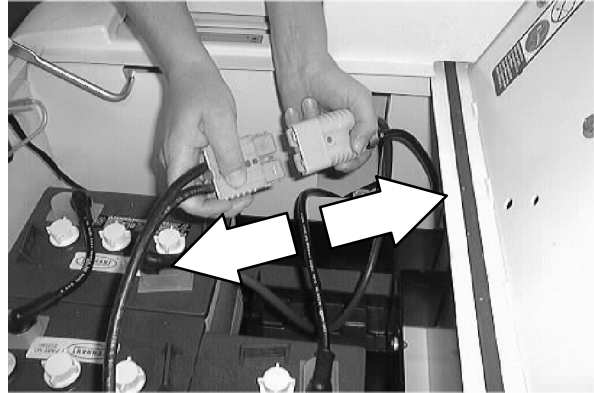

- Reconnect the battery connector to the machine connector.

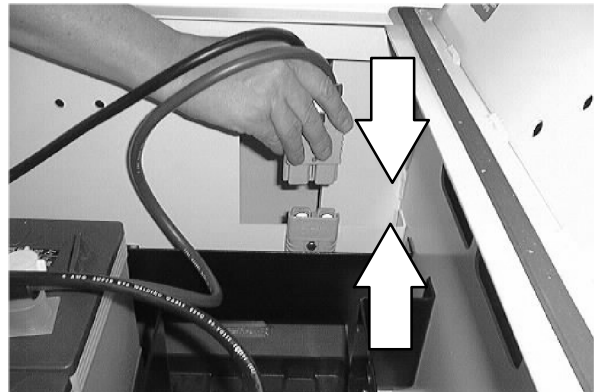

- Check the electrolyte level in each battery cell. Add just enough distilled water to bring the electrolyte level up to the bottom of the fill rings.

FOR SAFETY: When maintaining or servicing machine, avoid contact with battery acid.

- Close the seat support.

TO REPLACE BATTERIES

FOR SAFETY: Before Leaving Or Servicing Machine; Stop On Level Surface, Set Parking Brake.

1. Open the seat support and engage the prop rod.

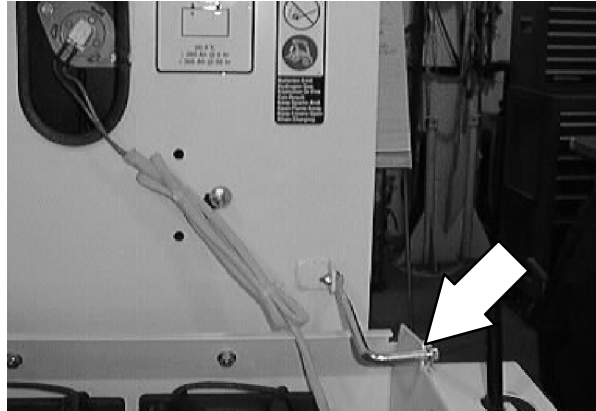

2. Disconnect the machine batteries.

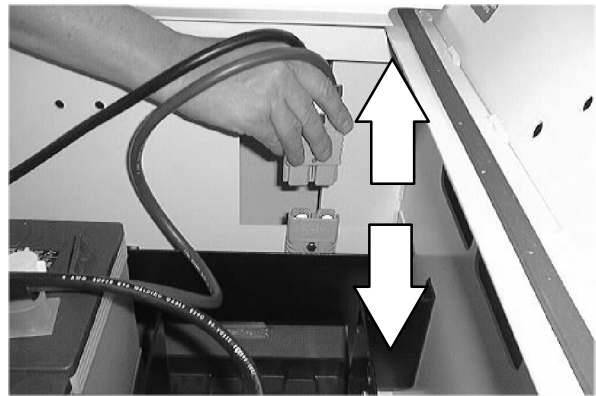

3. Remove the five small battery cables from the batteries.



4. Disconnect the connector assembly from the batteries.



5. Remove the two batteries nearest the rear of the machine first by lifting with the lifting loop at each end of the battery



6. Pull the four batteries nearest the front of the machine toward the rear of the battery tray. Remove these batteries next.



7. Install the four front batteries first. Push these batteries toward the front of the machine.

8. Install the rear two batteries next.

9. Reinstall the five small battery cables onto the new batteries (see fig next page).



ELECTRICAL

10. Reinstall the connector assembly onto the batteries.



11. Reconnect the battery connect to the machine connector.

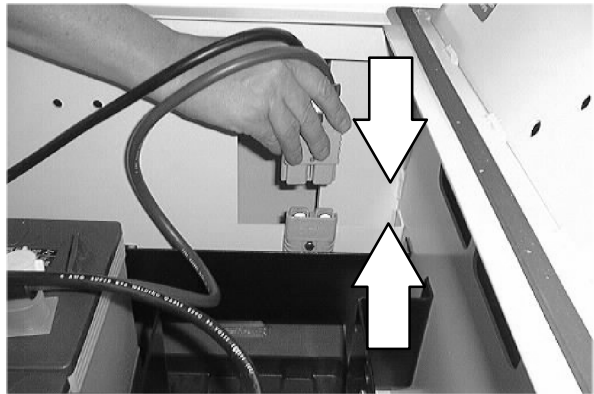

12. Disengage the prop rod and lower the seat support.

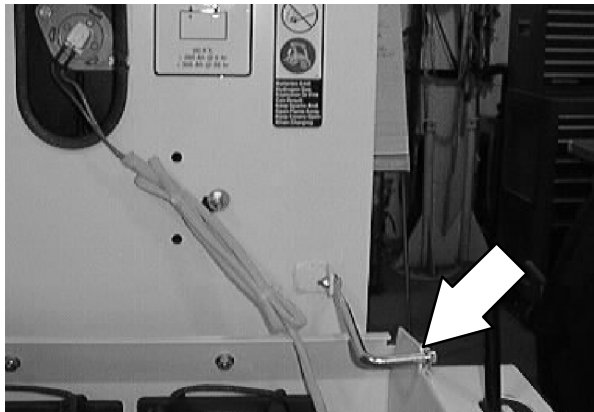

13. Start the machine and check the new batteries for proper operation.

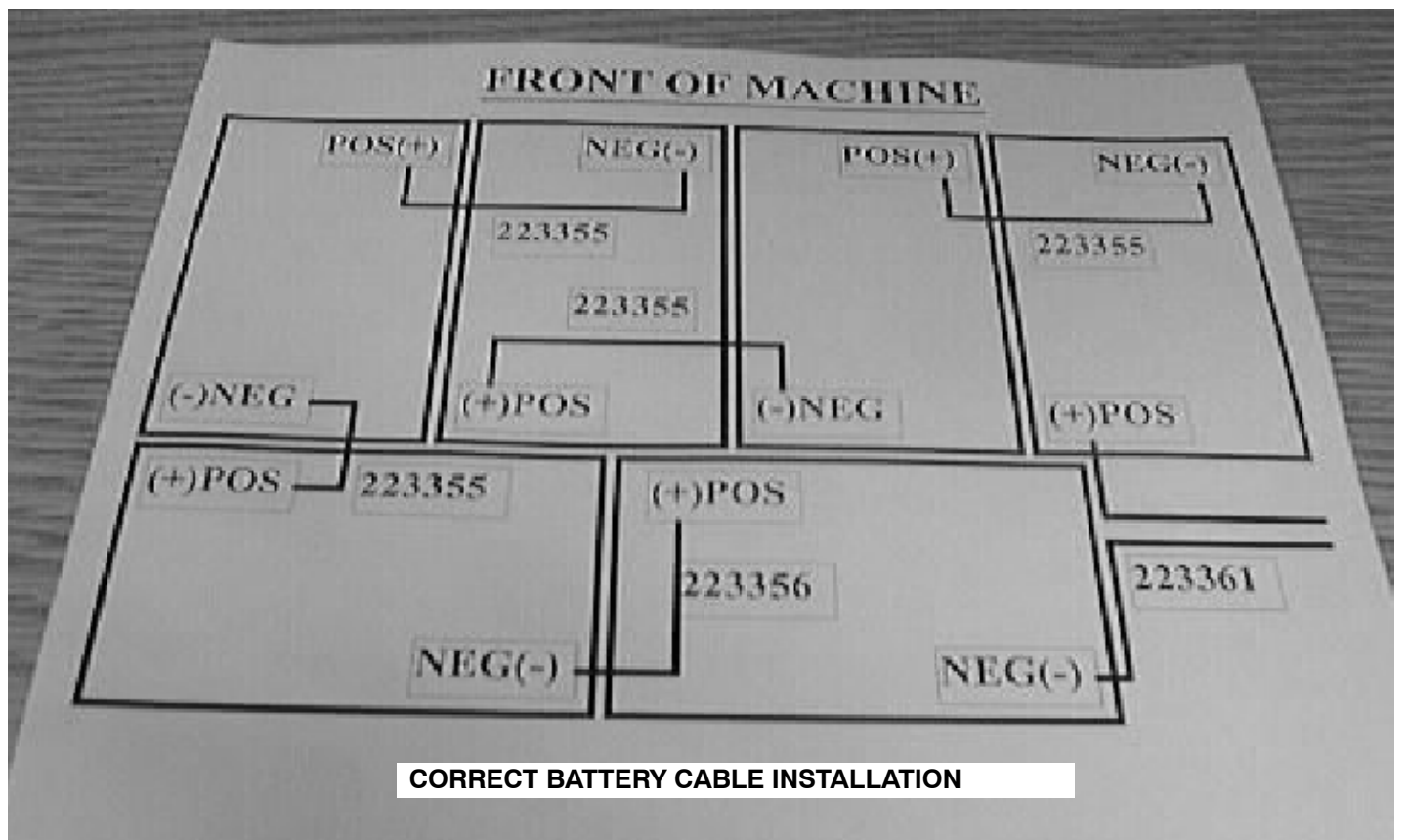
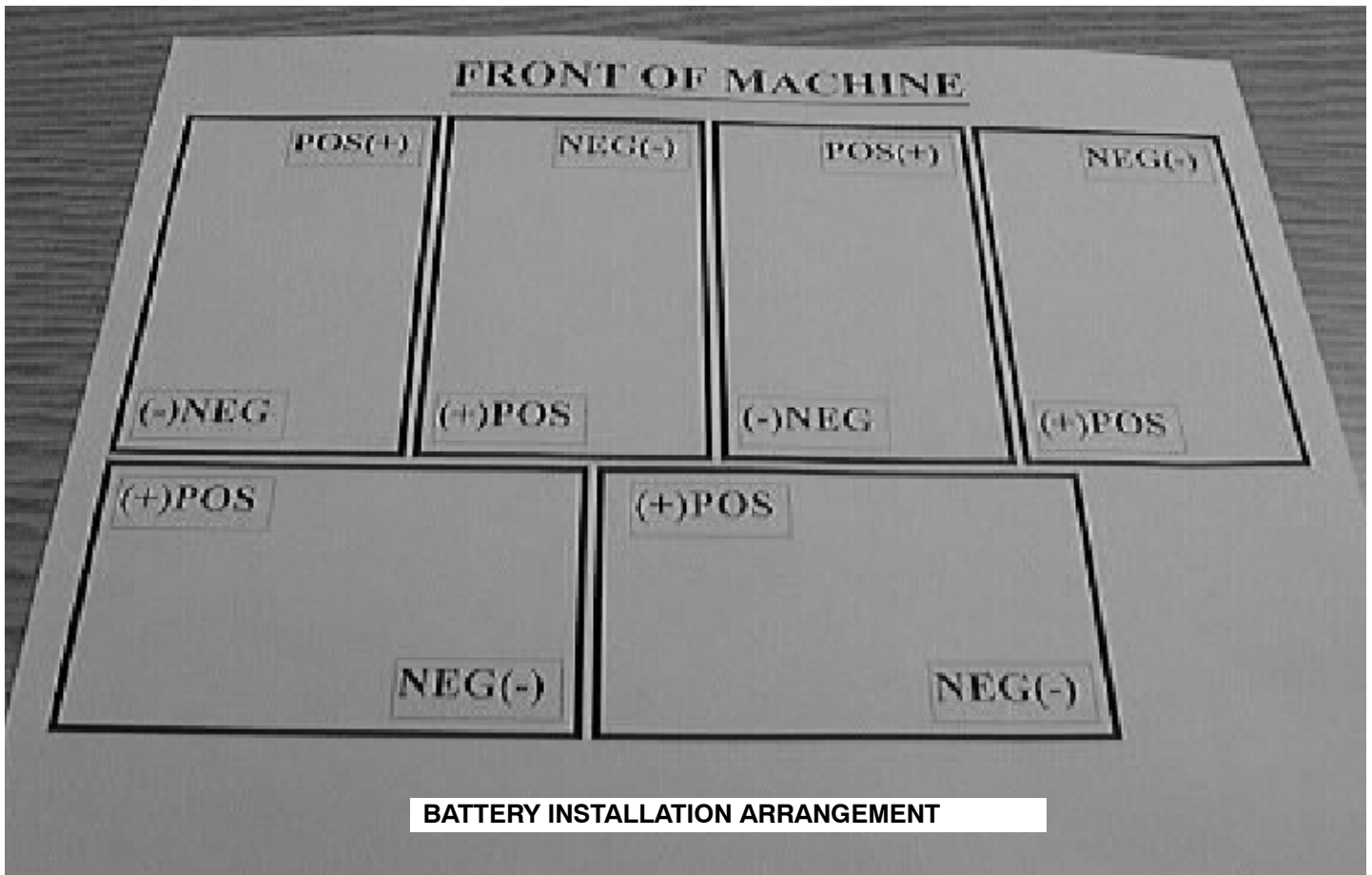

INSTRUMENT PANEL

The instrument panel on the model 6200E contains the switches, gauges, and instruments needed to run the machine functions.

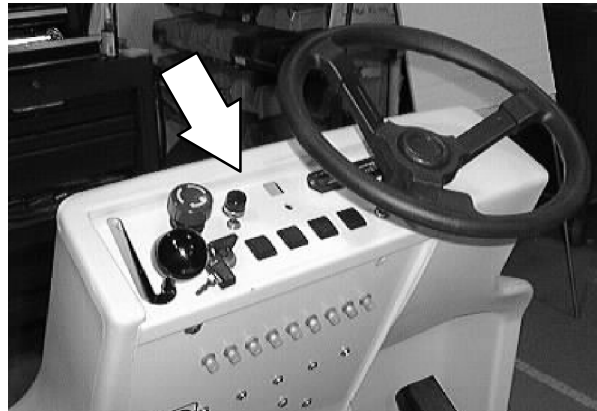

TO ACCESS CIRCUIT BREAKER OR INSTRUMENT PANEL

FOR SAFETY: Before Leaving Or Servicing Machine; Stop On Level Surface, Set Parking Brake.

1. Open the seat support and engage the prop rod.

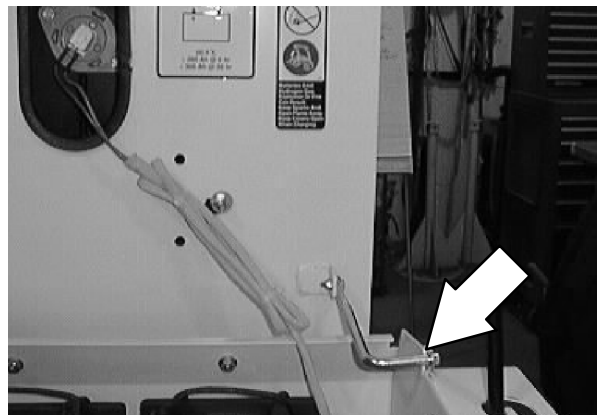

2. Disconnect the machine batteries.

3. Disengage the prop rod and lower the seat support.

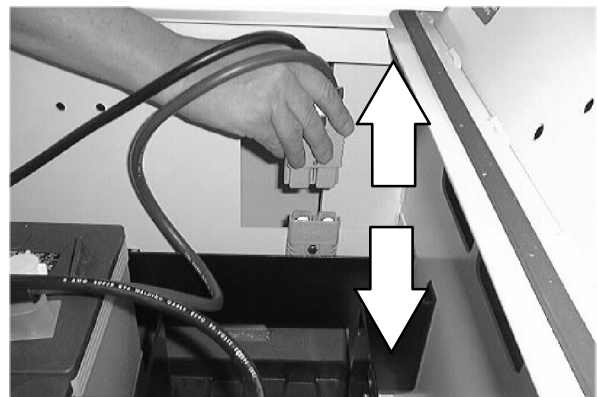

4. Remove the two hex screws holding the circuit breaker panel to the front shroud.

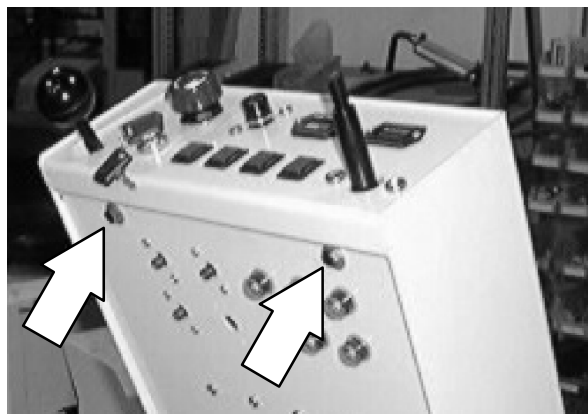

5. Pivot the circuit breaker panel back away from the front shroud.

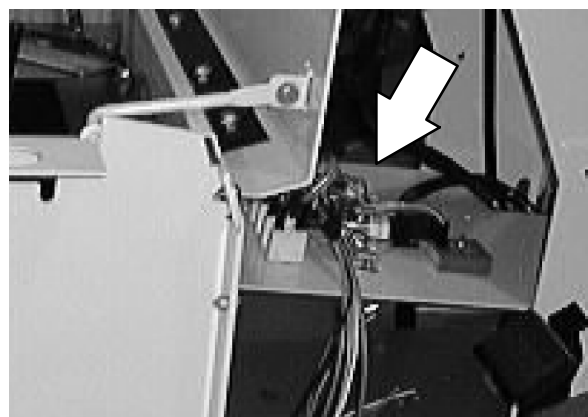

6. With the circuit breaker panel pivoted down, electrical components on the circuit breaker panel and the main instrument panel can be accessed.

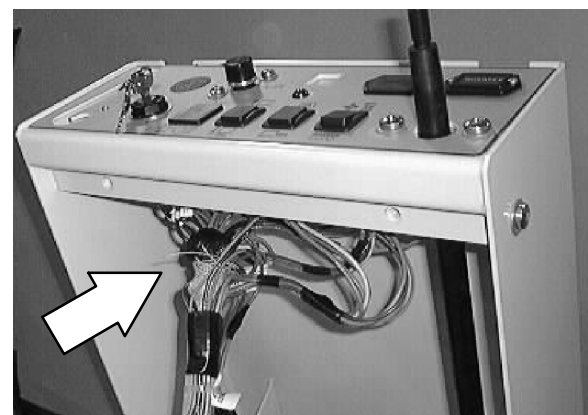

7. Pivot the instrument panel back up to the front shroud. Reinstall the hardware and hand tighten tight.

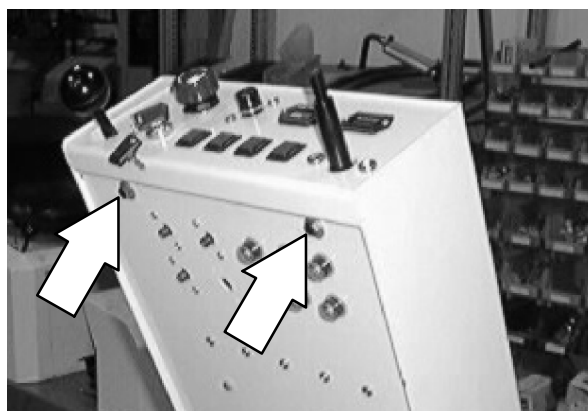

ELECTRICAL

8. Open the seat support and engage the prop rod.

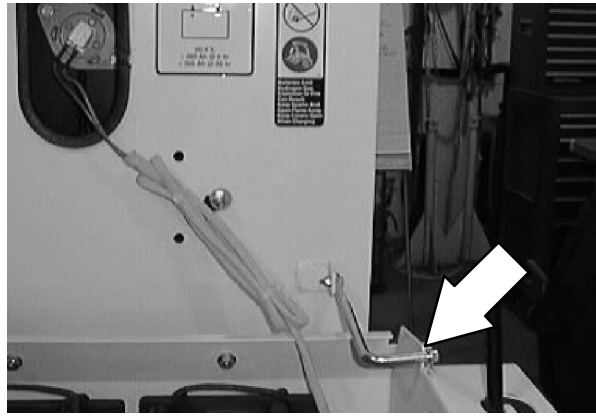

9. Reconnect the batteries.

10. Disengage the prop rod and lower the seat support.

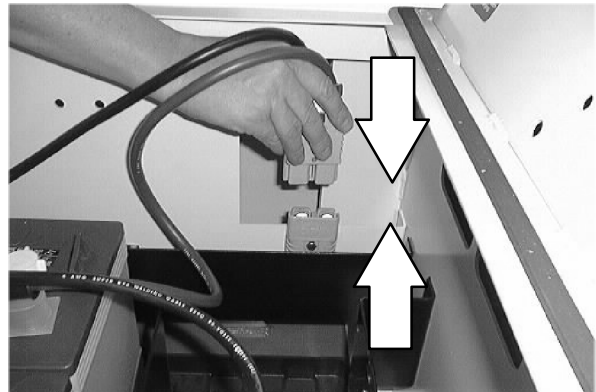

11. Start the machine and check for proper operation.

TO REPLACE CIRCUIT BREAKER

FOR SAFETY: Before Leaving Or Servicing Machine; Stop On Level Surface, Set Parking Brake.

1. Pull the instrument panel back away from the front shroud for better access to the circuit breakers. See TO ACCESS CIRCUIT BREAKER OR INSTRUMENT PANEL instructions.



2. Locate the circuit breaker that needs to be changed.

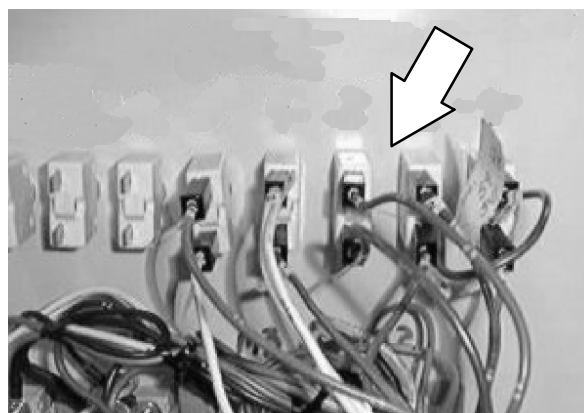

3. Mark and disconnect the wires leading to the back of the circuit breaker.

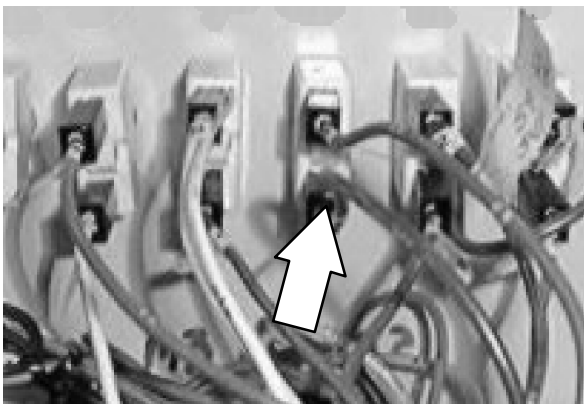

ELECTRICAL

4. Remove the water proof rubber boot from the circuit breaker. Retain the rubber boot.

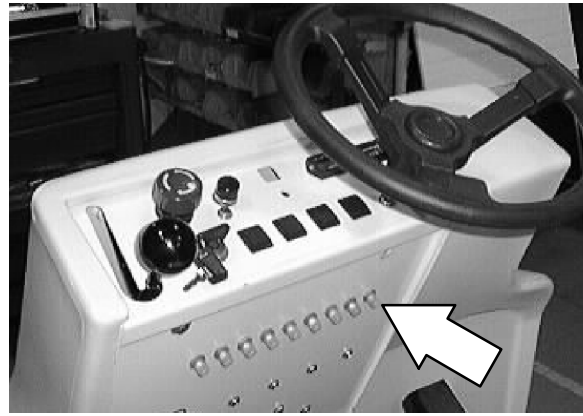

5. Remove the black threaded bushing from the front of the circuit breaker.
6. Push the circuit breaker out of the hole. Discard the circuit breaker.
7. Position the new circuit breaker into the mount hole. *NOTE: The mount hole has a "D" shape to match the shape of the circuit breaker.*
8. Install the black threaded bushing onto the new circuit breaker.
9. Install the rubber boot onto the out side of the new circuit breaker.

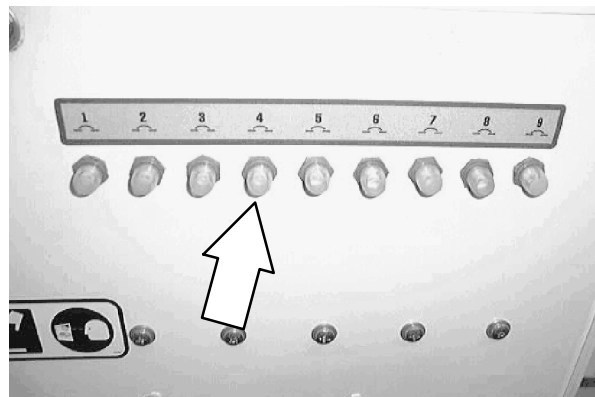
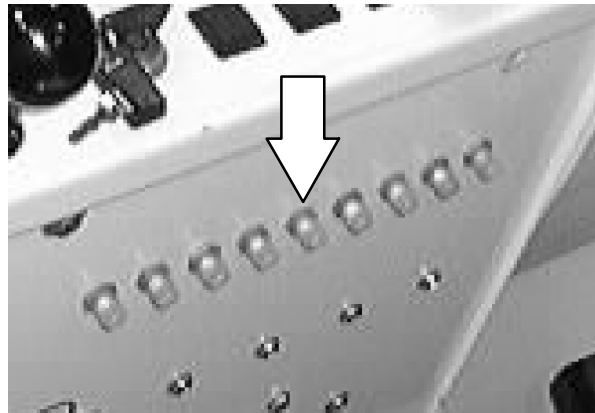

10. Reconnect the electrical wires to the new circuit breaker. See schematic in the ELECTRICAL section.

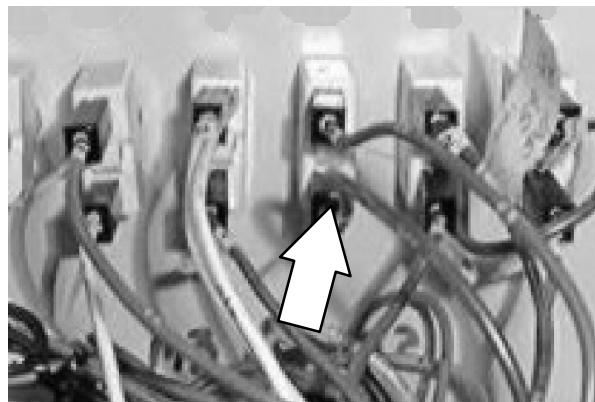

11. Pivot the instrument panel back onto the front shroud. Reinstall the hardware and hand tighten tight. See TO ACCESS CIRCUIT BREAKER OR INSTRUMENT PANEL instructions.

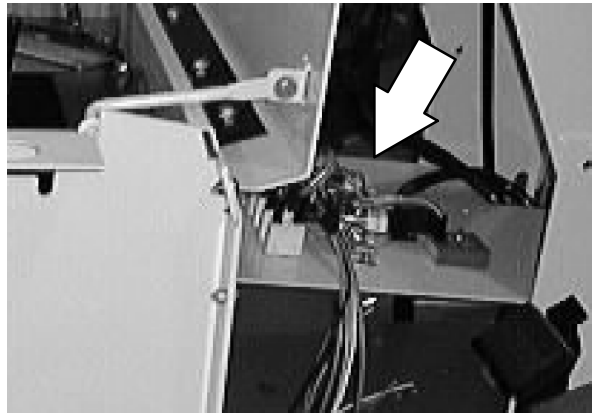

12. Start the machine and check the new circuit breaker for proper operation.

ELECTRICAL

TO REPLACE 80 AMP FUSE

FOR SAFETY: Before Leaving Or Servicing Machine; Stop On Level Surface, Set Parking Brake.

1. Pull the instrument panel back away from the front shroud for better access to the 80 amp. See TO ACCESS CIRCUIT BREAKER OR INSTRUMENT PANEL instructions.



2. Locate the 80 amp fuse above the propel controller, on the back of the pivot panel.

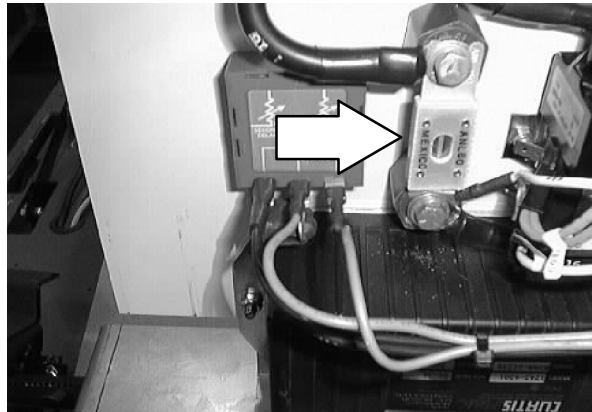

3. Loosen the two hex screws holding the fuse to the insulator stand offs.

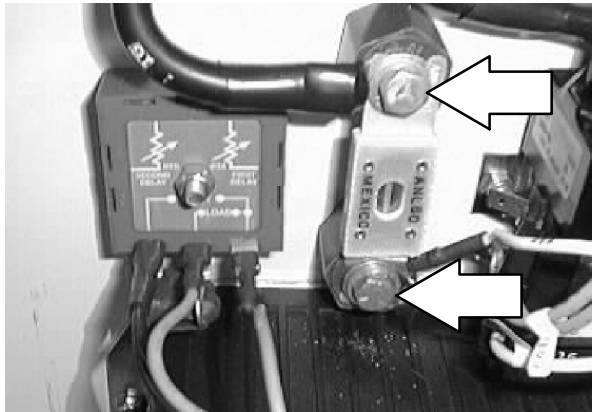

4. Pivot one end of the fuse up and off the hex screw, then slip the other end of the fuse from under the other hex screw. Remove and discard the fuse.
5. Install the new fuse under the two hex screws. Hand tighten the hex screws tight.

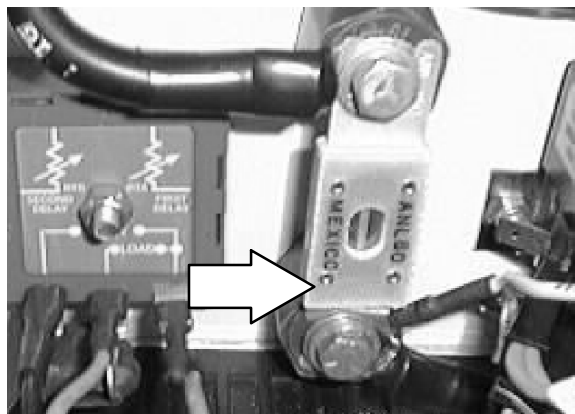

6. Pivot the instrument panel back onto the front shroud. Reinstall the hardware and hand tighten tight. See TO ACCESS CIRCUIT BREAKER OR INSTRUMENT PANEL instructions.

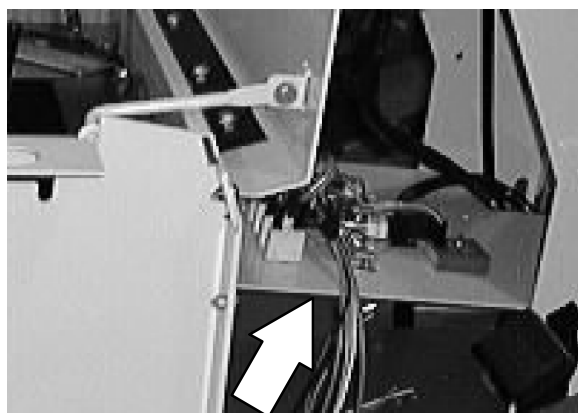

7. Start the machine and check the new 80 amp fuse for proper operation.

ELECTRICAL

FUSE

The Fuse is a one-time protection devices designed to stop the flow of current in the event of a circuit overload. Never substitute higher value fuses than specified.

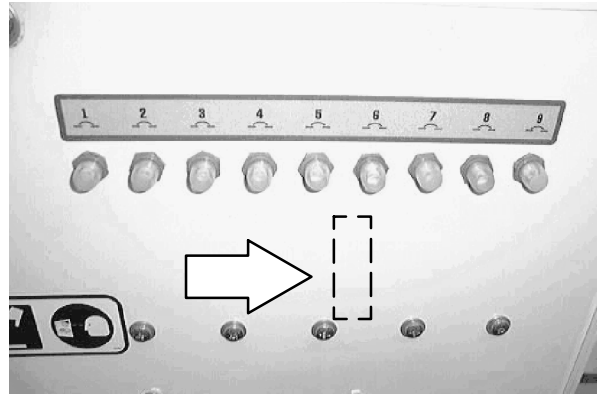

The fuse is located behind the circuit breaker panel.

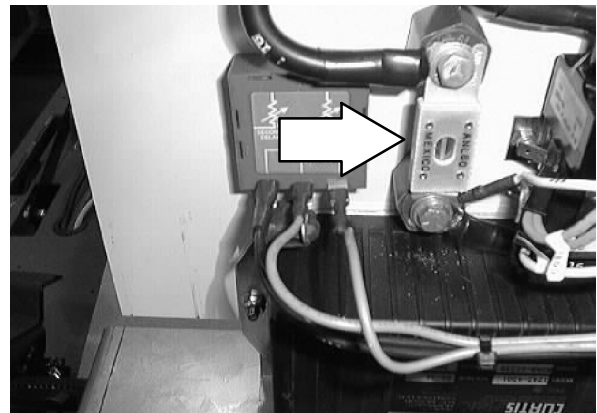

Fuse	Rating	Circuit Protected
FU-1	80 A	Main

CIRCUIT BREAKERS

The circuit breakers are resettable electrical circuit protection devices. Their design stops the flow of current in the event of a circuit overload. Once a circuit breaker is tripped, it must be reset manually. Press the reset button after the breaker has cooled down. The circuit breakers will not reset until they have had a chance to cool down.

If the overload that caused the circuit breaker to trip is still there, the circuit breaker will continue to stop current flow until the problem is corrected.

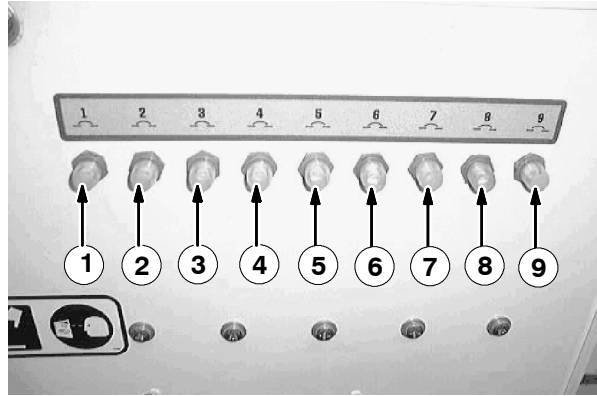

Circuit breakers 1 through 9 are located above the foot pedals in the circuit breaker panel.

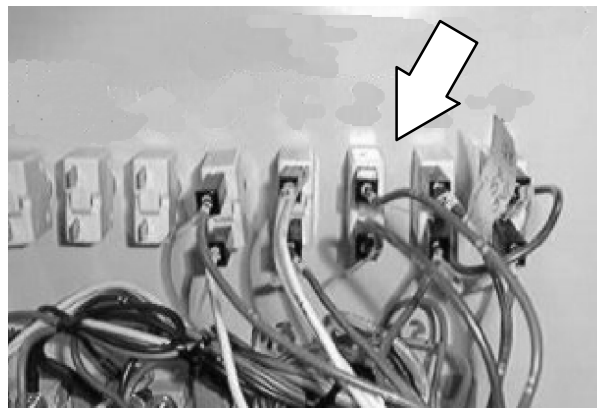

The chart lists the circuit breakers and the electrical components they protect.

Circuit Breaker	Rating	Circuit Protected
CB-1	15 A	Main Power
CB-2	15 A	Horn
CB-3	15 A	Side Brushes
CB-4	15 A	Hopper Door
CB-5	15 A	Oper. Lights Warning Lights
CB-6	20 A	Hopper Lift Pump
CB-7	20 A	Main Brush
CB-8	20 A	Sweep Fan Motor
CB-9	20 A	Vac Wand (Option)

TO REPLACE PROPEL CONTROLLER

FOR SAFETY: Before Leaving Or Servicing Machine; Stop On Level Surface, Set Parking Brake.

1. Pull the instrument panel back away from the front shroud for better access to the propel controller. See TO ACCESS CIRCUIT BREAKER OR INSTRUMENT PANEL instructions.



2. Locate the propel controller on the lower edge of the pivot panel.

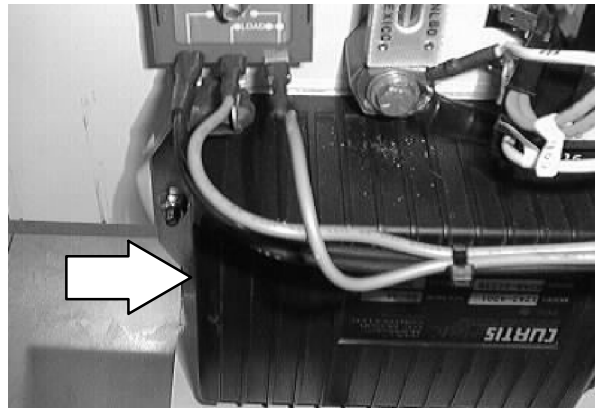

3. Mark and disconnect the wires leading to the propel controller.

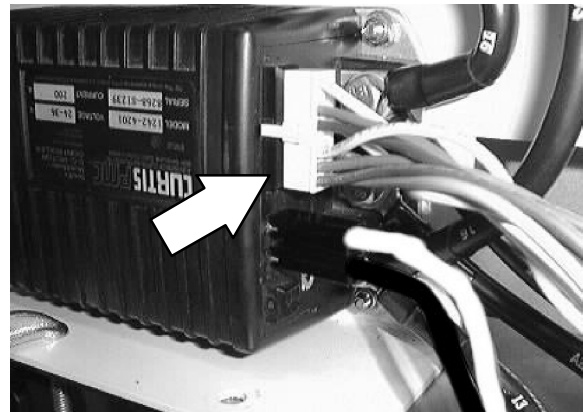

4. Remove the four screws and nuts holding the controller to the electrical panel. Remove the controller from the machine.
5. Install the new controller onto the electrical panel in the same orientation as the old one. Reinstall the hardware and hand tighten.

NOTE: Do not over tighten.

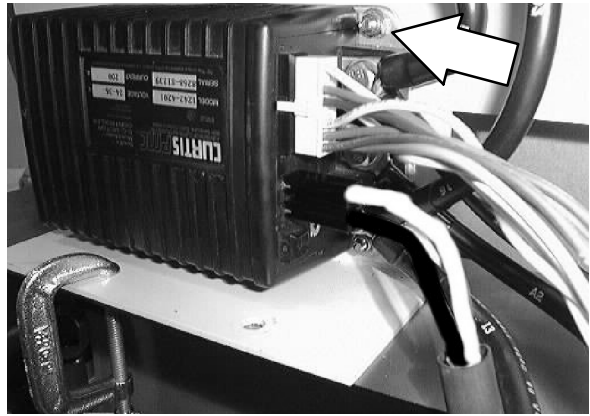

6. Reconnect the wires to the new controller. See schematic in this section.

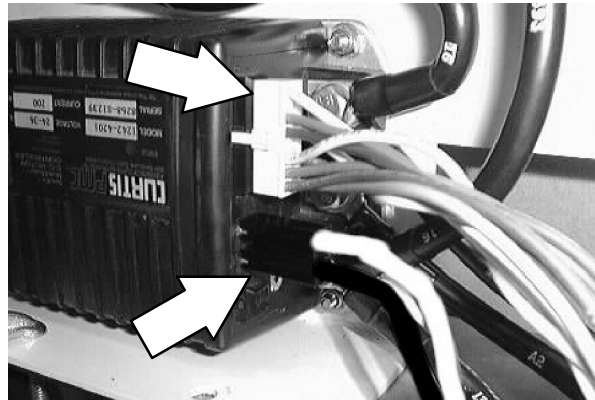

7. Pivot the instrument panel back onto the front shroud. Reinstall the hardware and hand tighten tight. See TO ACCESS CIRCUIT BREAKER OR INSTRUMENT PANEL instructions.



8. Start the machine and check the new controller for proper operation.

DIRECTIONAL PEDAL

The directional pedal controls the direction of travel and the propelling speed of the machine. Change the speed of the machine with the pressure of your foot on the pedal; the harder you press the faster the machine travels.

Use the brake pedal to stop the machine.



TO REMOVE DIRECTIONAL PEDAL ASSEMBLY

FOR SAFETY: Before Leaving Or Servicing Machine; Stop On Level Surface, Set Parking Brake.

1. Open the seat support and engage the prop rod.

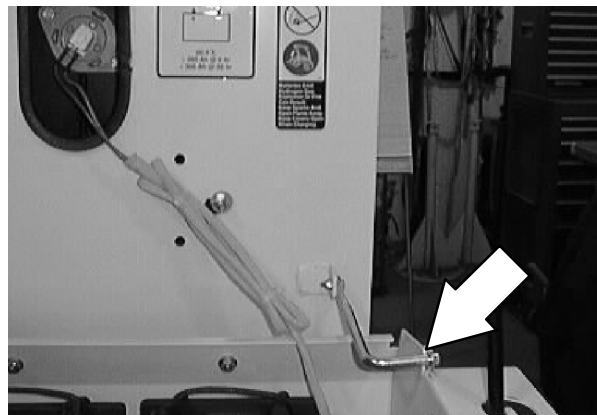

2. Disconnect the machine batteries.

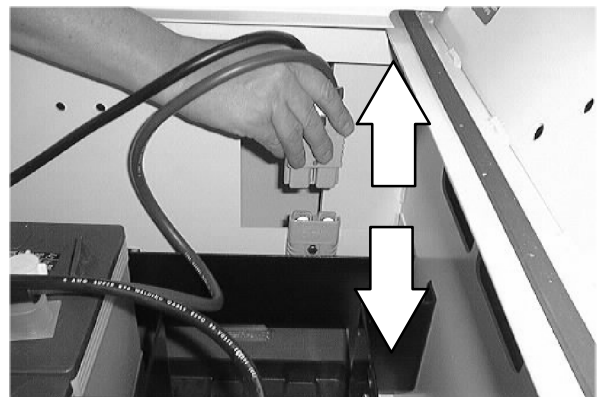

3. Lower the side brush.

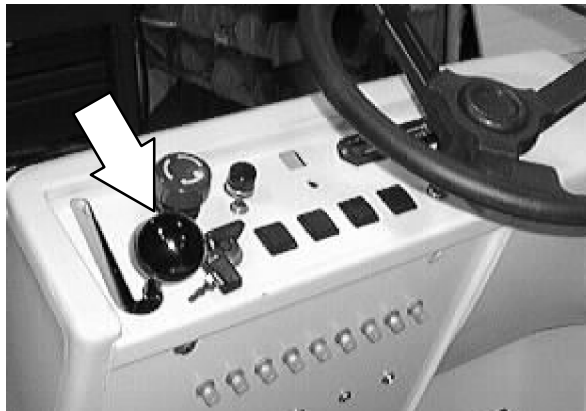

4. Go under the machine in the area of the right hand side brush. Locate the wires and connector leading from the directional pedal.

5. Disconnect the directional pedal connector from the main harness. Remove any plastic ties holding the directional pedal harness to the main harness.

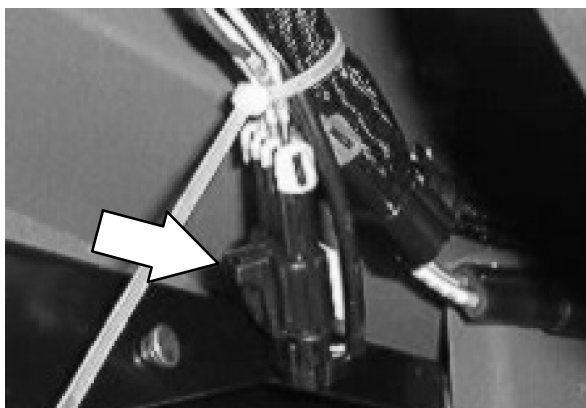

6. Go to the operators compartment and locate the directional pedal assembly. Remove the four thread rolling screws holding the directional pedal to the floor plate.

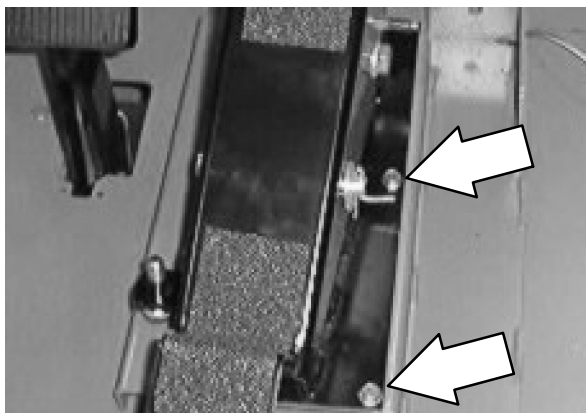

7. Remove the pedal assembly from the machine.

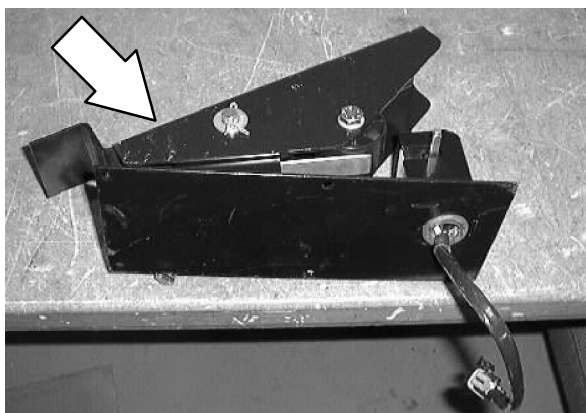

TO INSTALL DIRECTIONAL PEDAL ASSEMBLY

FOR SAFETY: Before Leaving Or Servicing Machine; Stop On Level Surface, Set Parking Brake.

1. Position the directional pedal assembly in the machines operators compartment.

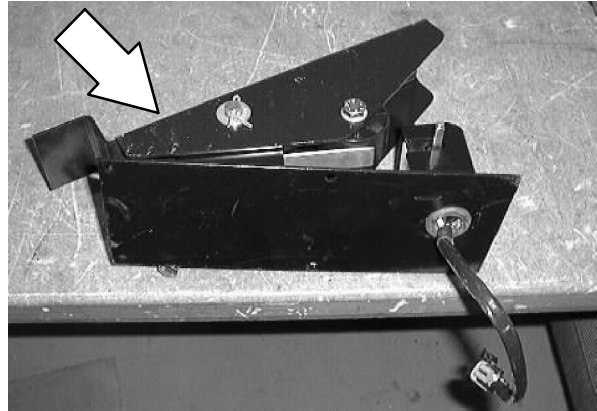

2. Feed the pedal harness down through the access hole in the floor plate.

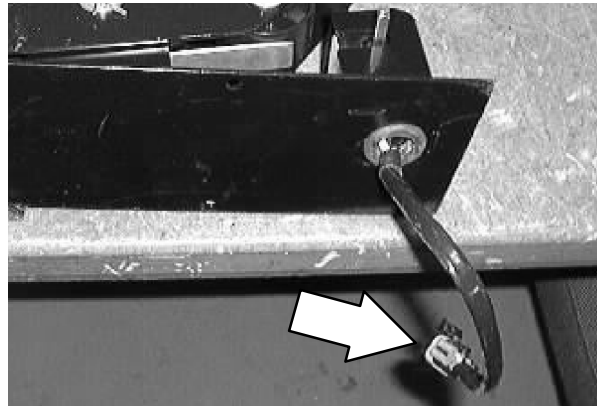

3. Line up the mount holes in the pedal assembly plate with the mount holes in the machines floor plate.

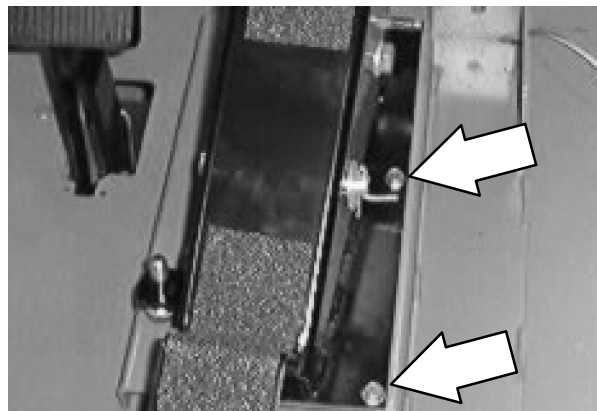

4. Reinstall the four thread rolling screws and tighten to 8 - 10 Nm (6 - 7 ft lb).

5. Go under the machine in the area of the right hand side brush. Locate the wires and connector leading from the directional pedal.

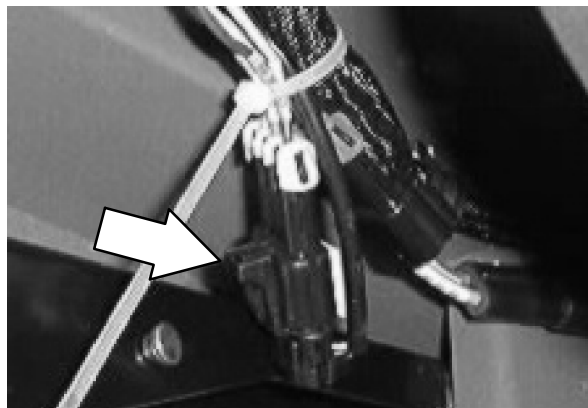

6. Reconnect the directional pedal connector to the main harness. Reinstall any plastic ties that were holding the directional pedal harness to the main harness.

7. Reconnect the batteries.

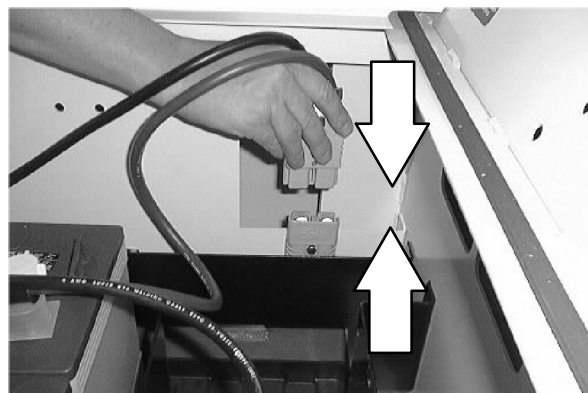

8. Disengage the prop rod and lower the seat support.

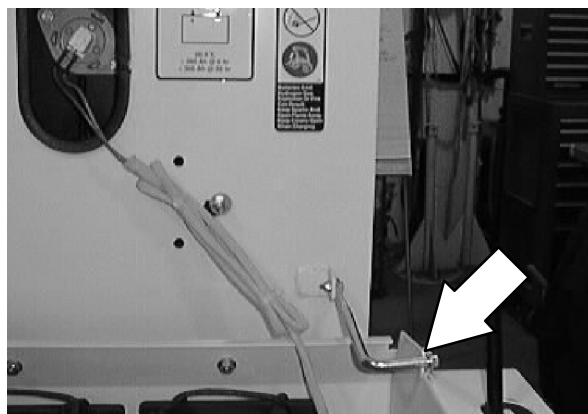

9. Start the machine and check for proper operation.

TO REPLACE DIRECTIONAL CONTROL UNIT

FOR SAFETY: Before Leaving Or Servicing Machine; Stop On Level Surface, Set Parking Brake.

1. Remove the directional pedal assembly from the machine. See TO REMOVE DIRECTIONAL PEDAL ASSEMBLY instructions in this section.

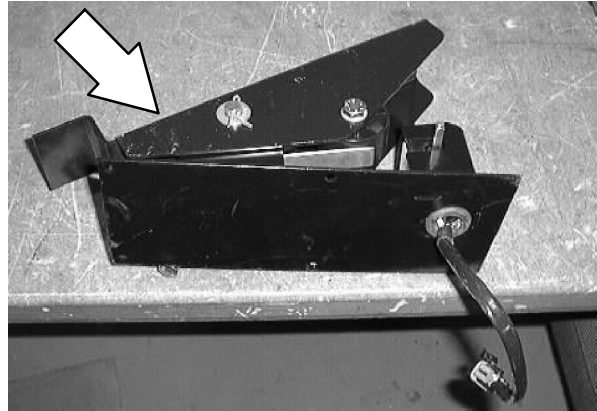

2. Loosen the hex screw and nut holding the accelerator lever to the potentiometer. Remove the accelerator lever from the potentiometer shaft.

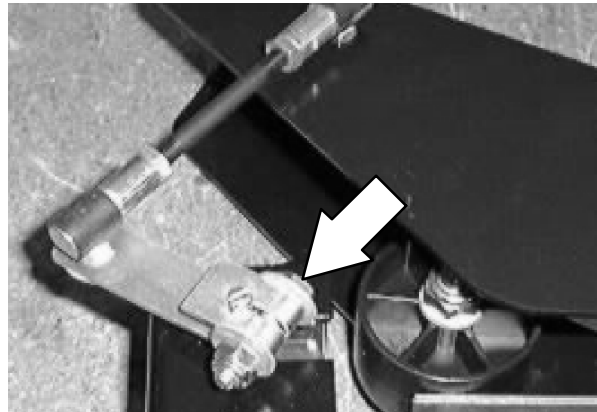

3. Remove the two screws holding the directional control unit to the propel pedal assembly.

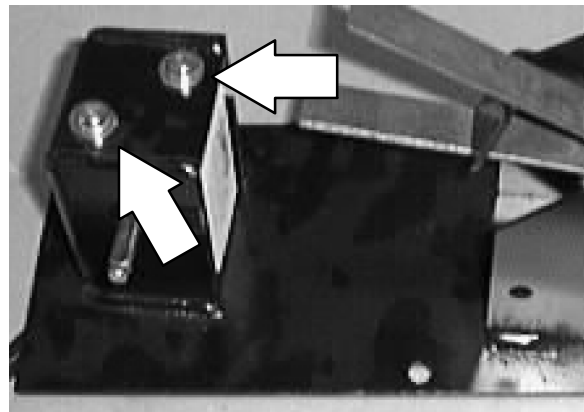

- Note the orientation of the existing directional control unit. Remove it from the pedal assembly.
- Install the new directional control unit onto the pedal assembly in the same orientation as the old one. Reinstall the two screws and hand tighten tight.

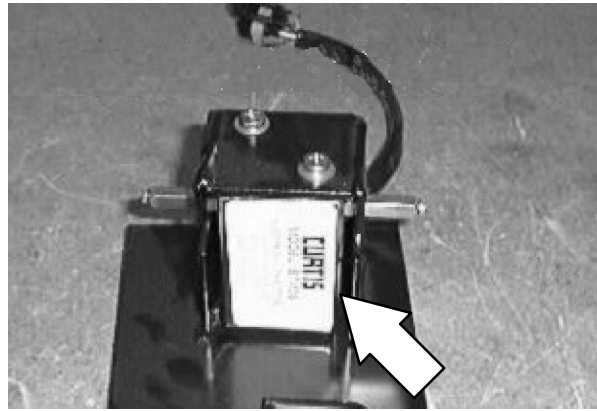

- With the directional pedal in the neutral position, reinstall the accelerator lever onto the shaft of the potentiometer. Hand tighten the hex screw and nut.

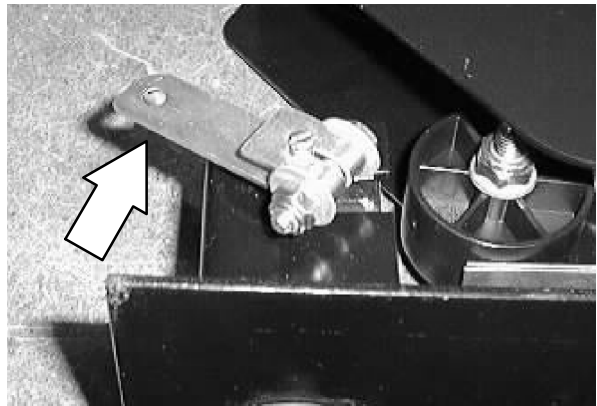

- Check the length of the threaded rod/ball joint assembly. Measure the distance between the ball joint centers. The dimension should be approximately 4 inches. If an adjustment needs to be made, loosen the upper jam nut and turn the rod. Re-tighten the jam nut.

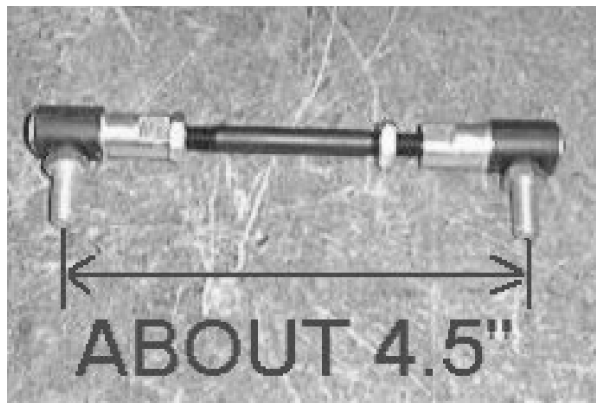

- Reinstall the directional pedal assembly into the machine. See TO INSTALL DIRECTIONAL PEDAL ASSEMBLY instructions in this section.

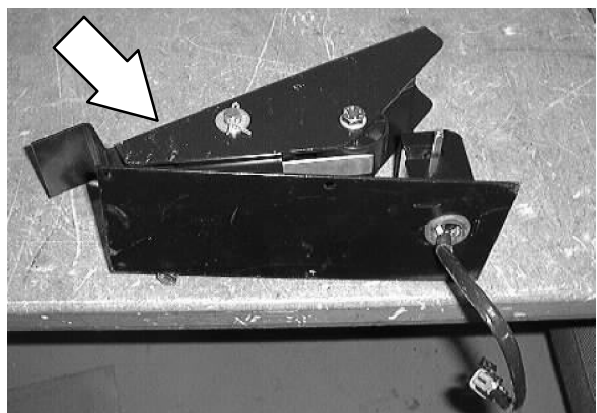

- Operate the machine. Check the new directional control unit for proper operation.

ELECTRIC MOTORS

The carbon brushes on the propelling and main brush motor should be inspected after every 800 hours of machine operation.

TO REPLACE FRONT DRIVE WHEEL MOTOR

FOR SAFETY: Before Leaving Or Servicing Machine; Stop On Level Surface, Set Parking Brake.

1. Raise the seat support and unplug the battery connectors.
2. Raise the front of the machine and place jack stands under the frame.
3. Mark and remove the electrical cables leading to the drive motor.

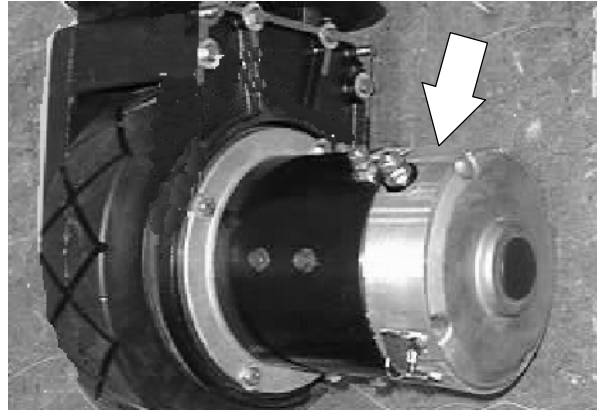

4. Remove the 4 hex screws holding the electric drive motor to the drive assembly outer plate. Remove the drive motor.

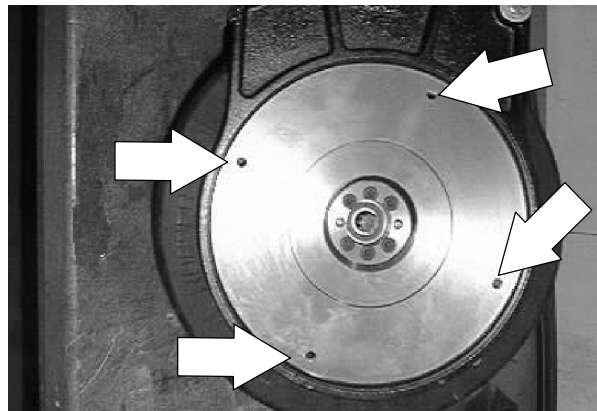

NOTE: When installing the motor on the drive assembly, make sure the terminals are pointing up and slightly forward for proper electrical cable installation.

5. Install the new drive motor on the drive assembly. Make sure to line up the splines on the motor shaft with the splines of the planetary gear box. Tighten the 4 hex screws to 18 - 24 Nm (15 - 20 ft lb).

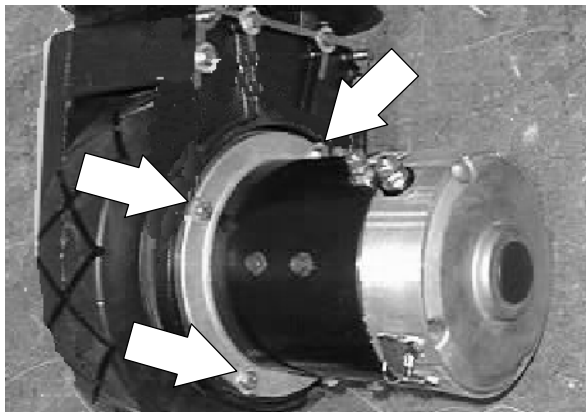

6. Reconnect the electrical cables to the drive motor.



7. Remove the jack stands and lower the machine.

8. Reconnect the battery cables.

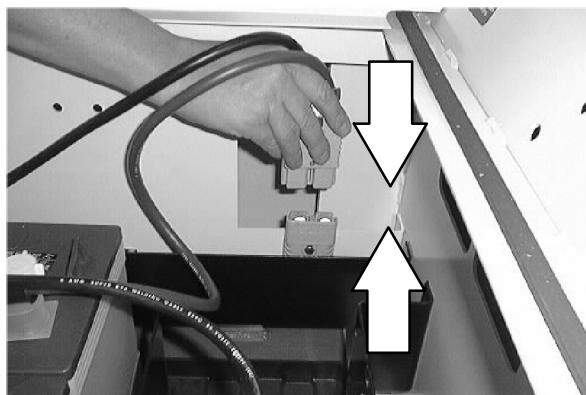

9. Operate the machine and check the new drive motor for proper operation.

TO REPLACE MAIN BRUSH MOTOR

FOR SAFETY: Before Leaving Or Servicing Machine; Stop On Level Surface, Set Parking Brake.

1. Jack up the front of the machine at the jack point. Install jack stands under the machine frame.
2. Lower the main brush lever.

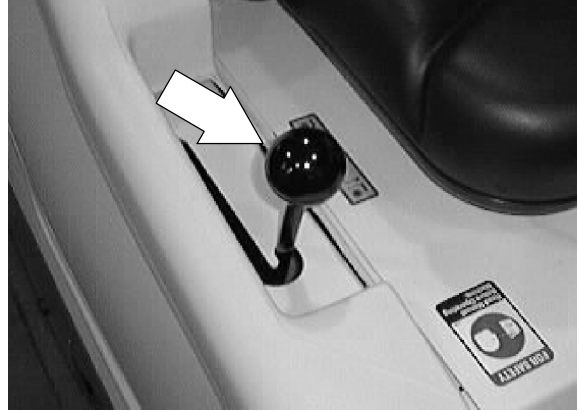

3. Open the seat support and engage the prop rod.

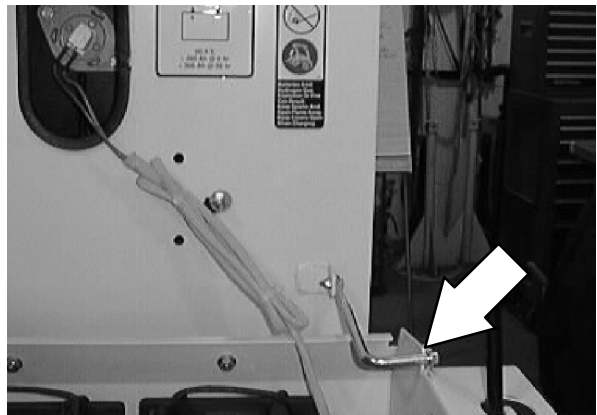

4. Disconnect the machine batteries.

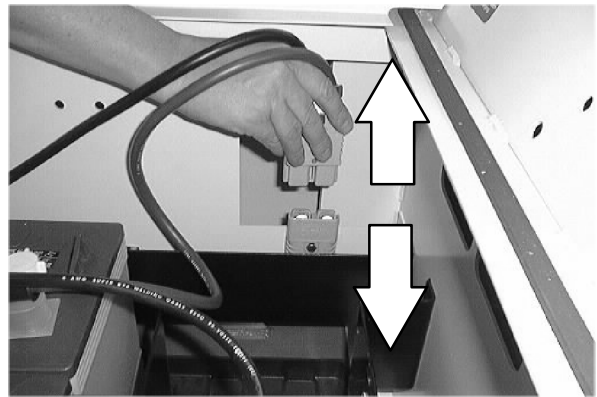

5. Remove the four screws holding the right hand brush door to the machine frame. Remove the right hand side brush door.

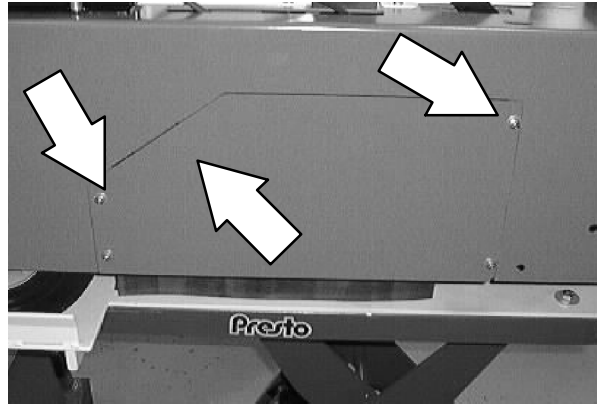

6. Locate the main brush drive belt idler pulley between the small motor drive pulley and the larger brush pulley.
7. Loosen the hex nut in the center of the idler pulley.
8. Push the idler pulley back in the slot.
9. Remove the main brush drive belt from the two remaining pulleys. Remove the main brush drive belt.

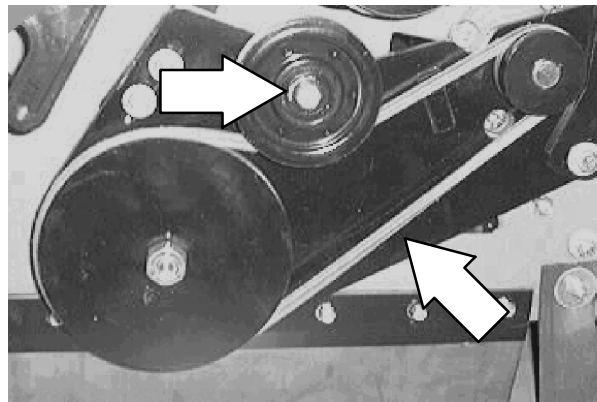

10. Loosen the two set screws holding the small V-belt pulley to the main brush motor shaft. Pull the pulley off the shaft. Retain the square key.

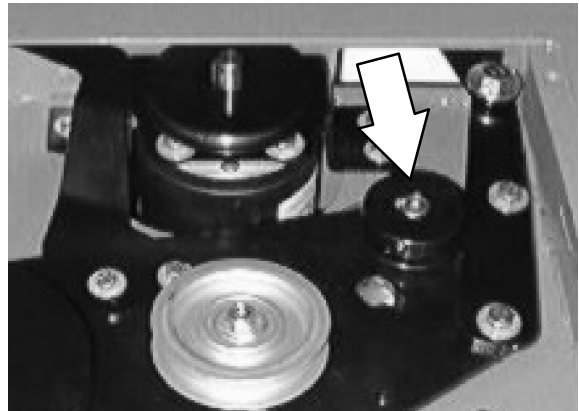

11. Remove the two hex screws holding the brush arm lift link to the front of the brush arm weldment.

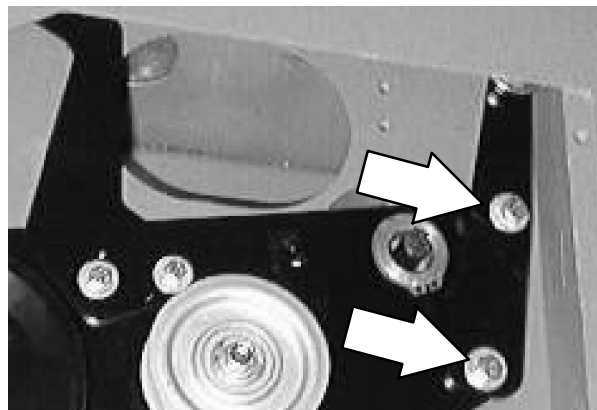

ELECTRICAL

12. Remove the four flat head screws holding the main brush motor to the motor pivot plate and machine frame.

NOTE: You may have to rotate the brush arm weldment to line up the access holes.

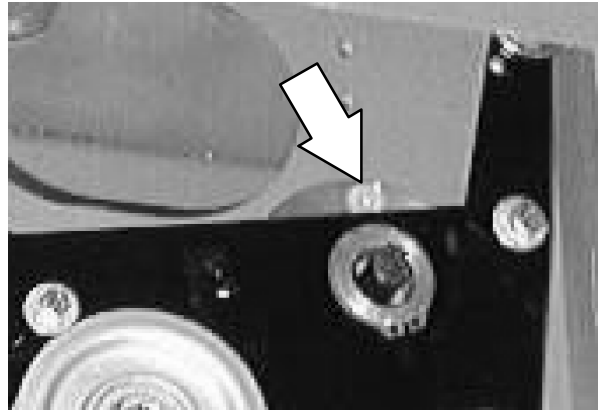

13. Go under the front of the machine and locate the main brush motor behind the front drive assembly. Disconnect the main brush motor from the main harness.

14. Remove the main brush motor from the machine.

NOTE: Note the orientation of the motor and electrical wires.

15. Install the new main brush motor into the machine.

NOTE: Make sure to orientate the motor so the wires are pointed to the front of the machine.

16. Connect the new main brush motor to the main harness.
17. Wire tie the motor wires to the motor housing.

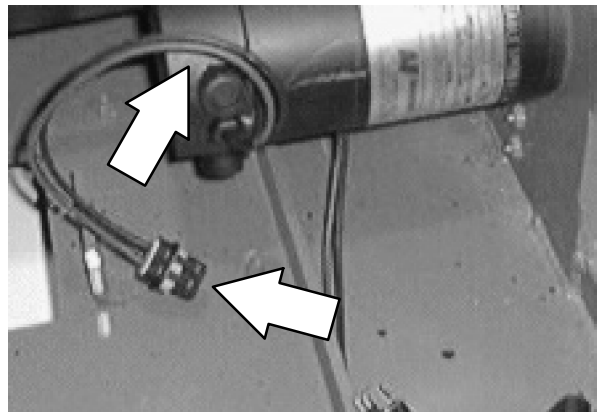
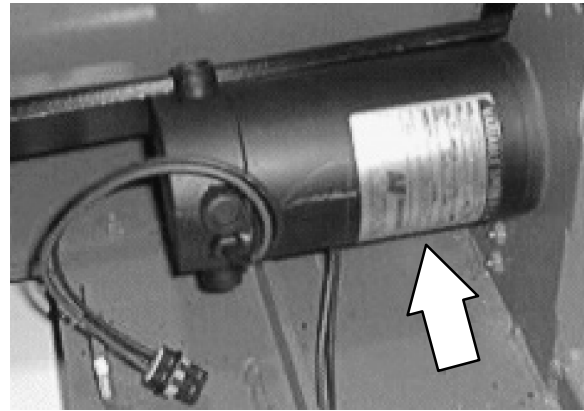

18. Line up the mount holes in the new motor with the mount holes in the machine frame and motor pivot plate. Reinstall the four flat head screws. Tighten to 11 - 14 Nm (7 - 10 ft lb).

NOTE: You may have to rotate the brush arm weldment to line up the access holes.

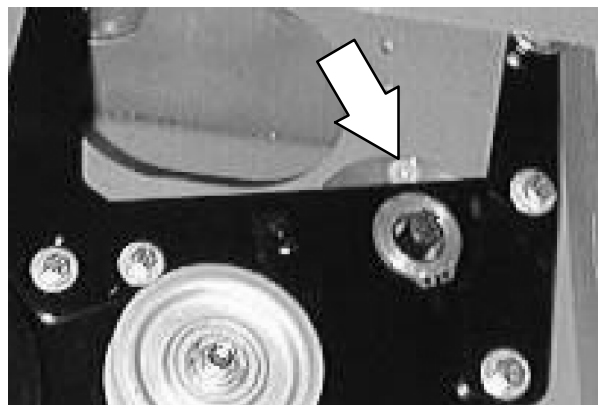

19. Reinstall the brush arm lift link to the front of the brush arm weldment. Reinstall the two hex screws and tighten to 18 - 24 Nm (15 - 20 ft lb).

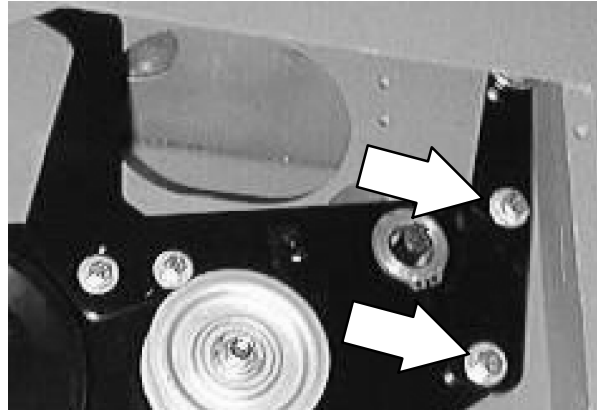

20. Reinstall the small main brush V-belt pulley onto the new main brush motor shaft. Line up the small V-belt pulley with the larger V-belt pulley. Make sure the square key is installed on the shaft. Hand tighten the two set screws.

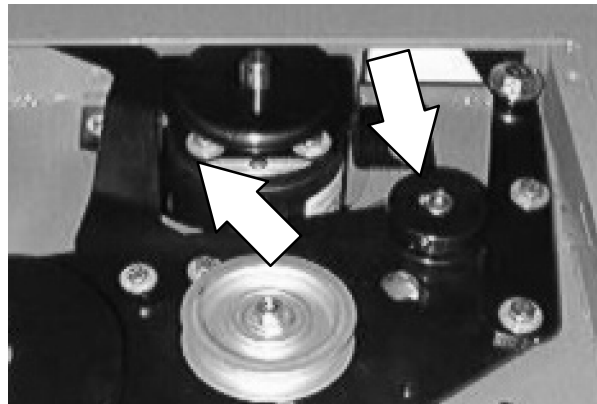

21. Position the main brush drive belt onto the motor and brush drive pulleys.
22. Move the idler pulley forward in the slot until the belt is tight. Tighten the hex nut to 18 - 24 Nm (15 - 20 ft lb).

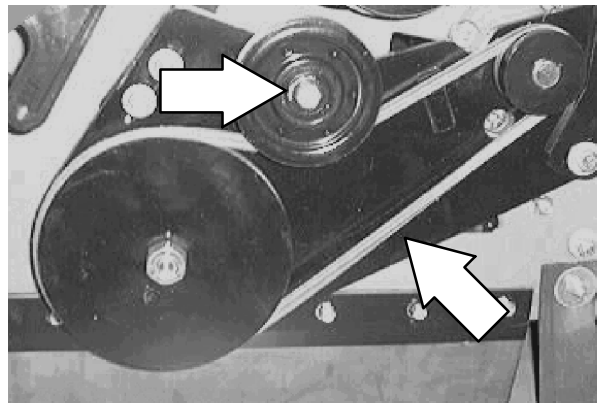

23. Reinstall the right hand side brush door.

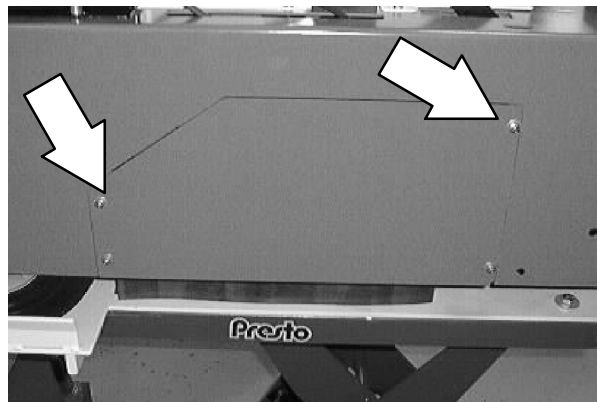

24. Reconnect the batteries.

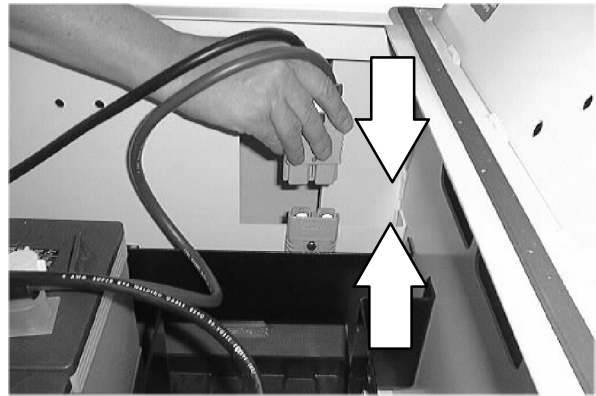

25. Disengage the prop rod and lower the seat support.

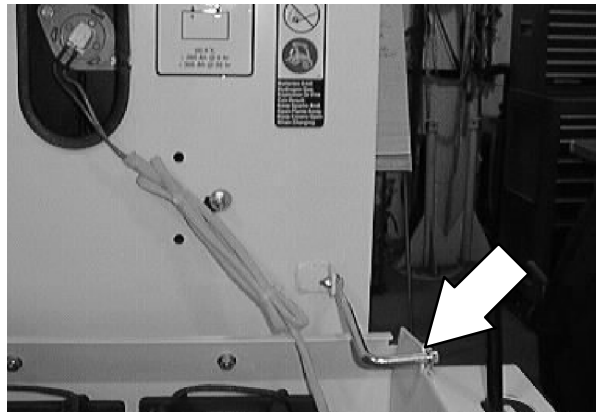

26. Remove the jack stands and lower the machine to the floor. Operate the machine and check the new main brush motor for proper operation.

TO REPLACE VACUUM FAN MOTOR

FOR SAFETY: Before Leaving Or Servicing Machine; Stop On Level Surface, Set Parking Brake.

1. The main brush motor must be removed before the vacuum fan motor can be removed. See TO REPLACE MAIN BRUSH MOTOR instructions in this section.

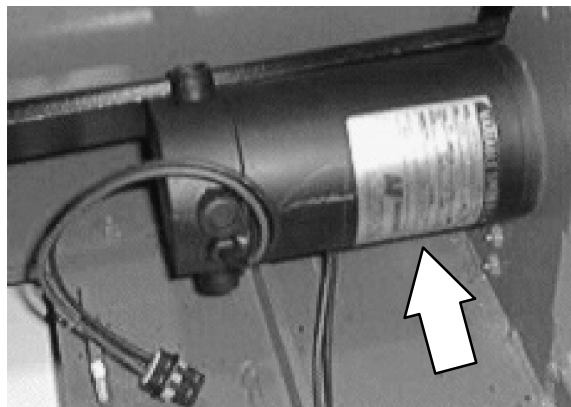

2. To access the vacuum fan drive belt, remove the right hand side panel. Start by lifting up on the panel, pop the brush lift slot over the black knob, then move the panel backward and off the machine.



3. Loosen the five hex screws holding the vacuum fan housing to the machine frame.

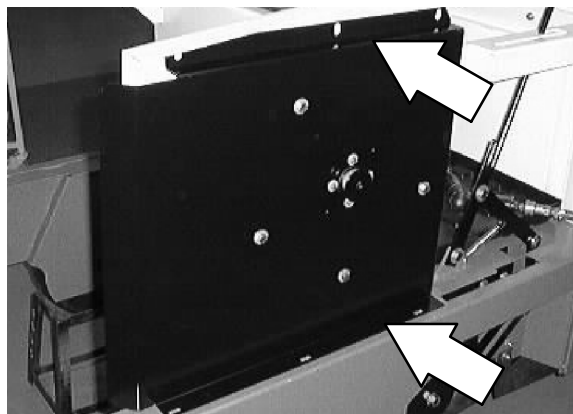

4. Push the vacuum fan assembly forward in the slots to loosen the vacuum fan V-belt.

5. Remove the V-belt from the vacuum fan motor pulley.

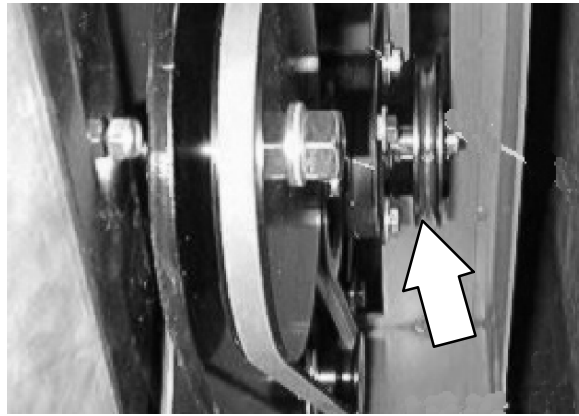

6. Loosen the set screws holding the vacuum fan V-belt pulley to the motor shaft. Pull the pulley off the shaft. Retain the square key.

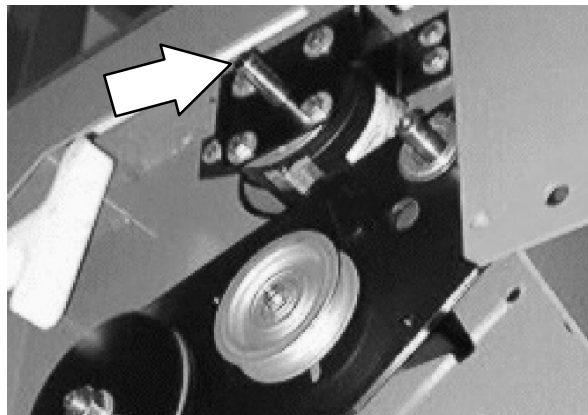

7. Remove the four hex screws holding the vacuum fan motor to the mount bracket.

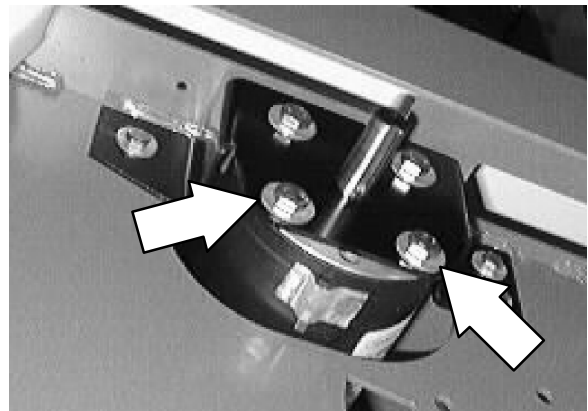

8. Go under the front of the machine and locate the vacuum fan motor behind the front drive assembly. Disconnect the vacuum fan motor from the main harness.

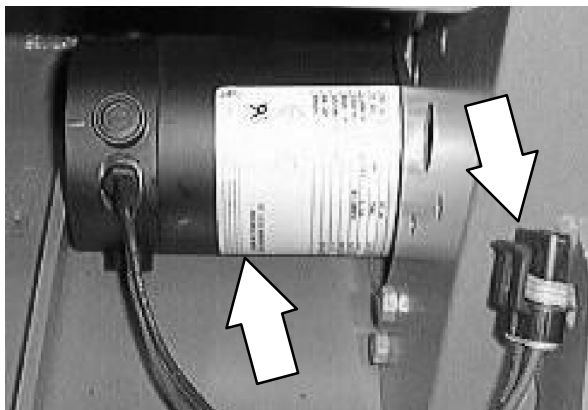

9. Remove the vacuum fan motor from the machine.

NOTE: Note the orientation of the motor and electrical wires.

10. Install the new vacuum fan motor into the machine.

NOTE: Make sure to orientate the motor so the wires are pointed to the front of the machine.



11. Reconnect the vacuum fan motor to the main harness.



12. Line up the mount holes in the new motor with the mount holes in the motor mount bracket. Reinstall the four hex screws. Tighten to 11 - 14 Nm (7 - 10 ft lb).

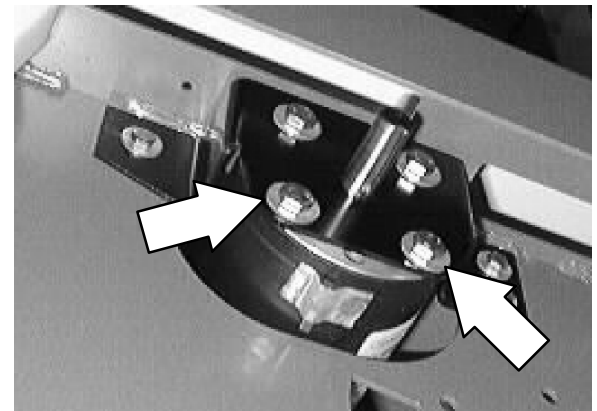

13. Reinstall the vacuum fan V-belt pulley onto the new vacuum fan motor shaft. Line up the V-belt pulley with the V-belt pulley up at the impeller. Make sure the square key is installed on the shaft. Hand tighten the two set screws tight.

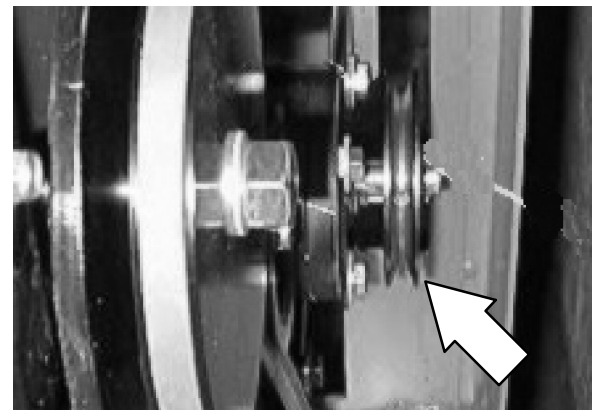

ELECTRICAL

14. Pull the vacuum fan assembly toward the back of the machine to tighten the V-belt. Tighten the four mounts screws hand tight.

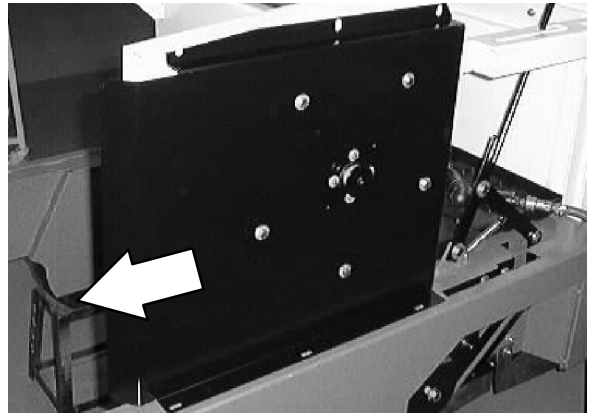

15. Reinstall the right hand machine cover.



16. Reinstall the right hand side brush door.

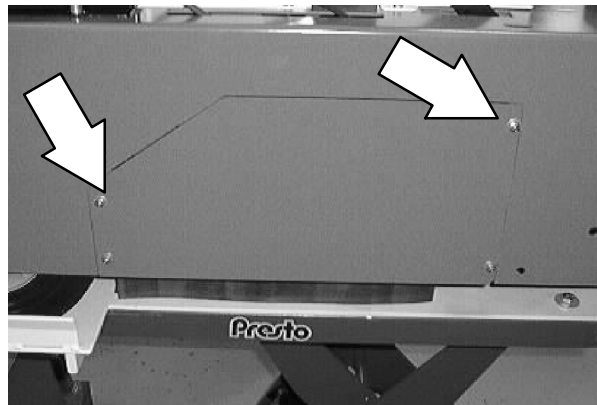

17. Reconnect the batteries.

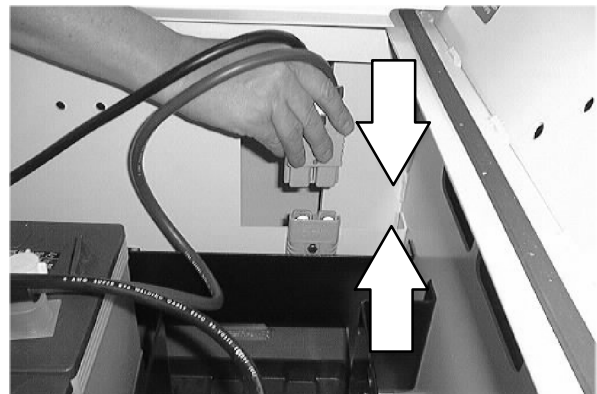

18. Disengage the prop rod and lower the seat support.
19. The main brush motor must be reinstalled after the vacuum fan motor has been replaced. See TO REPLACE MAIN BRUSH MOTOR instructions in this section.
20. Remove the jack stands and lower the machine to the floor. Operate the machine and check the new vacuum fan motor for proper operation.

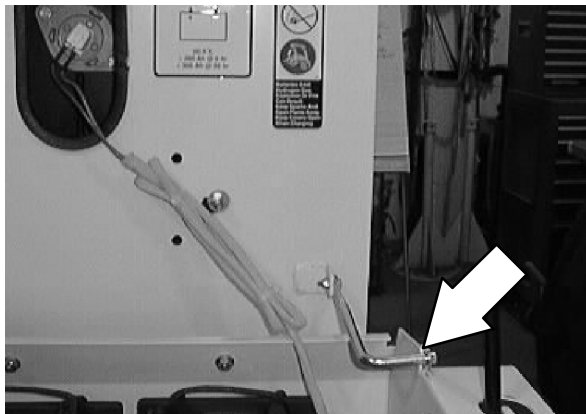

TO REPLACE SIDE BRUSH MOTOR

FOR SAFETY: Before Leaving Or Servicing Machine; Stop On Level Surface, Set Parking Brake.

1. Jack up the front of the machine at the jack point. Install jack stands under the machine frame.
2. Lower the side brush.

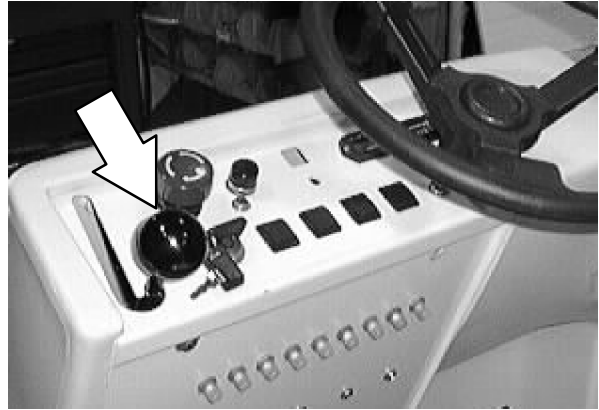

3. Remove the side brush from the motor assembly. See TO REPLACE SIDE BRUSH instructions in the SWEEPING section.



4. Disconnect the side brush motor from the main wire harness.

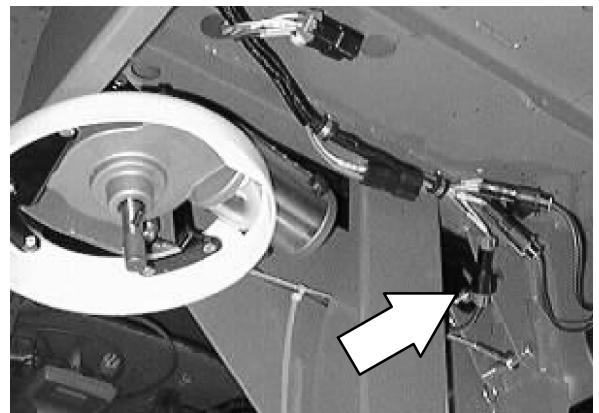

5. Remove the four hex screws holding the side brush motor to the motor mount bracket.
6. Drop the motor out of the mount bracket and past the brush guard.

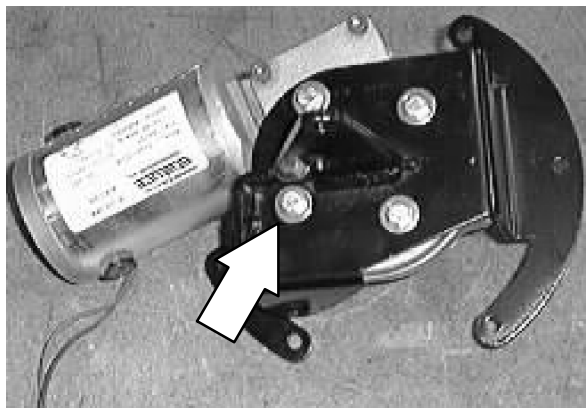

7. Position the new side brush motor onto the motor mount bracket. The motor is positioned to the rear of the machine.

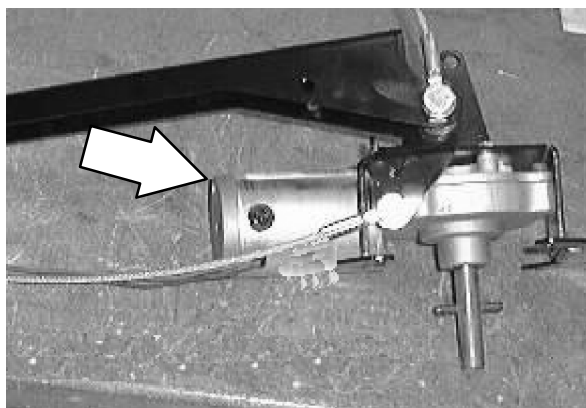

8. Line up the holes in the motor assembly with the mount holes in the motor bracket. Reinstall the four hex screws and tighten to 8 - 10 Nm (6 - 7 ft lb).



9. Reconnect the side brush motor to the main harness.

10. Wire tie the motor wires to the cable.

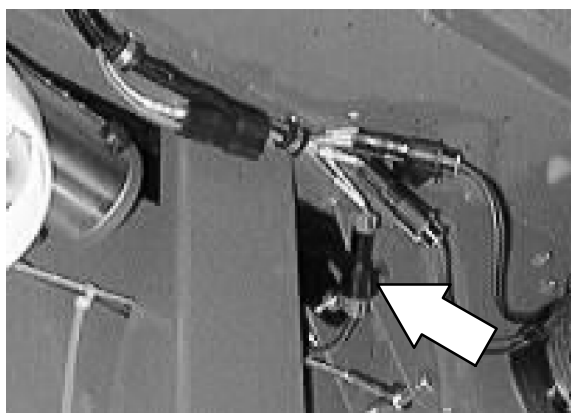

11. Reinstall the side brush. See TO REPLACE SIDE BRUSH instructions in the SWEEPING section.

12. Operate the machine. Check the new side brush motor for proper operation.



TO REPLACE DUMP DOOR ACTUATOR

FOR SAFETY: Before Leaving Or Servicing Machine; Stop On Level Surface, Set Parking Brake.

1. Place a wood block under the hopper dump door. Turn on the key and open the door until the two cables (one each side of the hopper) go slack.

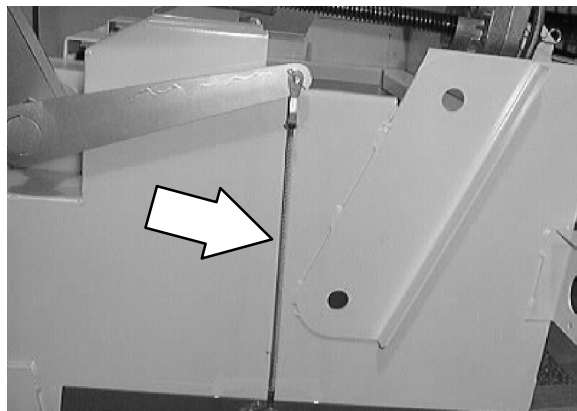

2. Un-latch and remove the hopper filter cover.

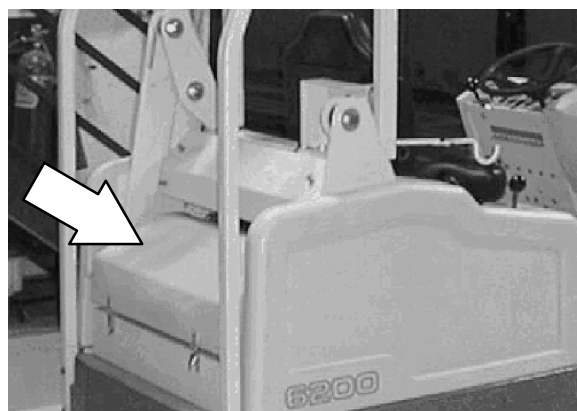

3. Locate the dump door actuator on the left side of the hopper panel filter and shaker.

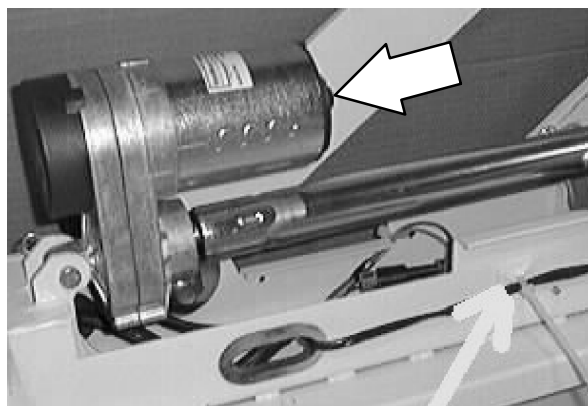

ELECTRICAL

4. Disconnect the actuator electrical plug from the main harness.

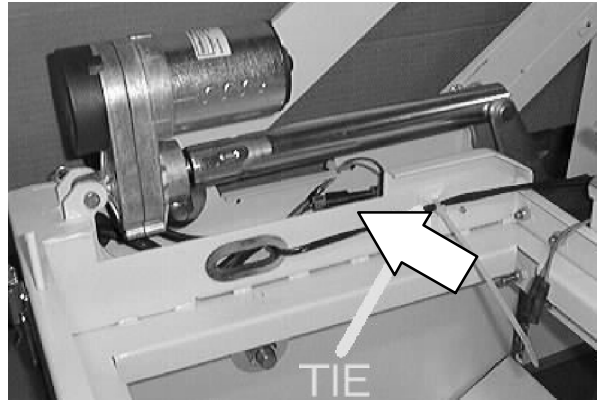

5. Remove the hair pin and clevis pin from each end of the actuator. Remove the actuator from the machine.

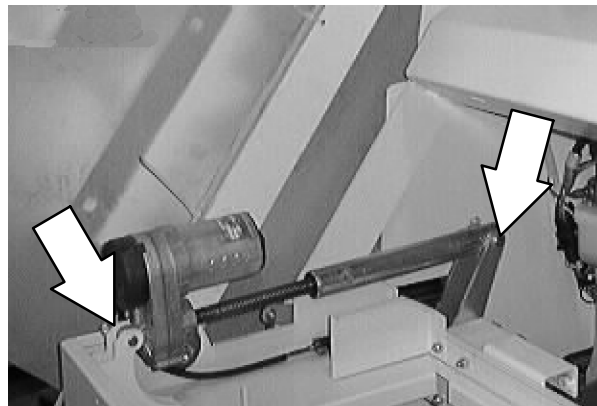

6. Install the new dump door actuator into the machine in the same orientation as the old one.

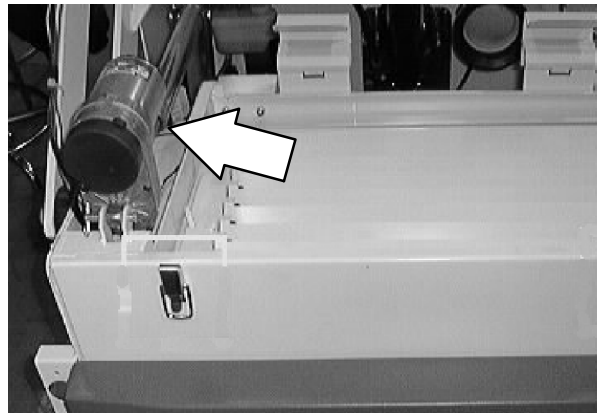

7. Reinstall the hair pin and clevis pin into each end of the new actuator.

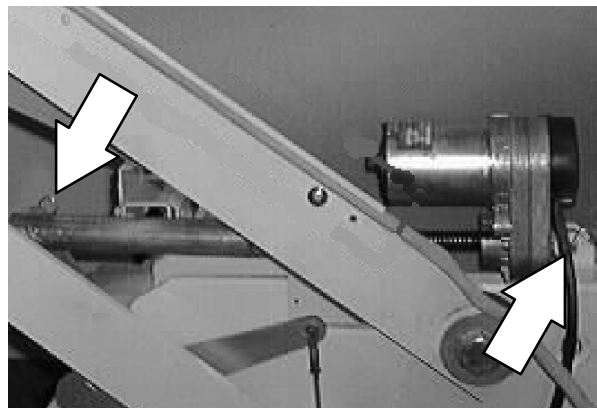

8. Connect the new dump door actuator to the main electrical harness.



9. Reinstall the hopper cover and latch it down.

10. Turn on the key and close the dump door. Remove the wood block from under the dump door.

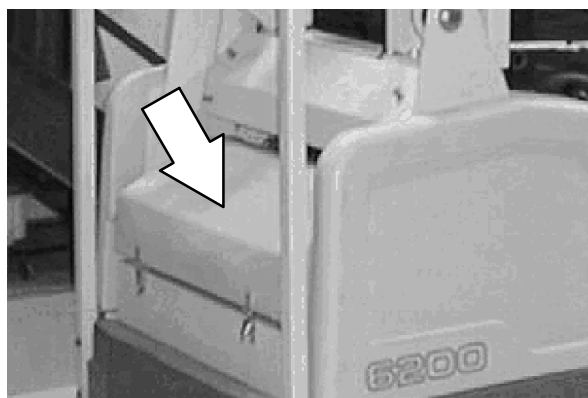

11. Operate the machine and check the new dump door actuator for proper operation.

THERMO SENTRY™

The Thermo Sentry™ is an electrical device used to detect excess heat or fire in the hopper filter area.



If fire is detected in the hopper filter area, the Thermo Sentry™ sends a signal to the vacuum fan electric motor. The vacuum fan motor will turn off if the Thermo Sentry™ detects a fire.

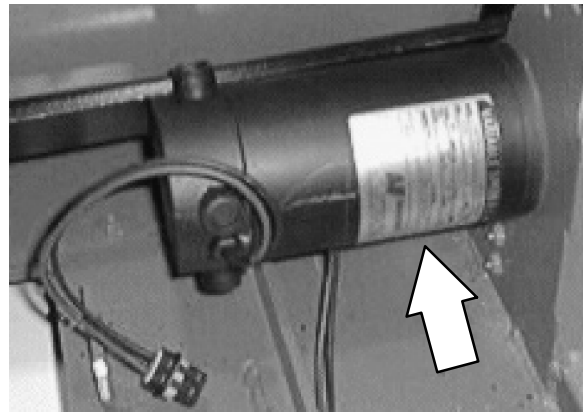

TO REPLACE THERMO SENTRY™

FOR SAFETY: Before Leaving Or Servicing Machine; Stop On Level Surface, Set Parking Brake.

1. Un-latch and remove the hopper filter cover.

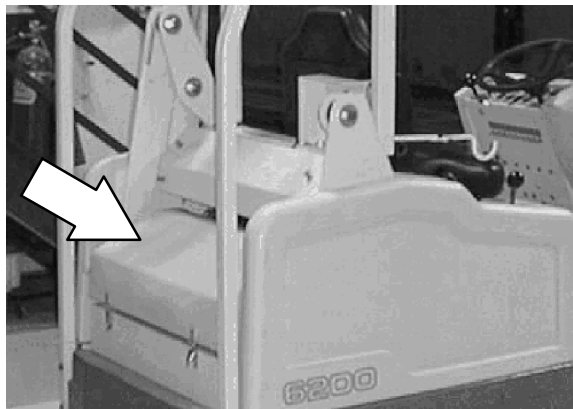

2. Locate the Thermo Sentry™ at the back side of the 90 degree section of the vacuum tube.

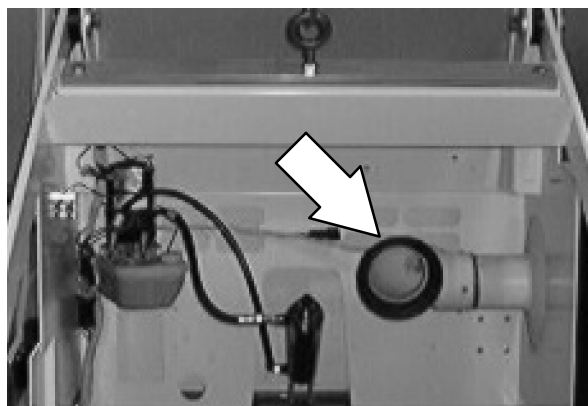

3. Remove the wires leading to the Thermo Sentry™.

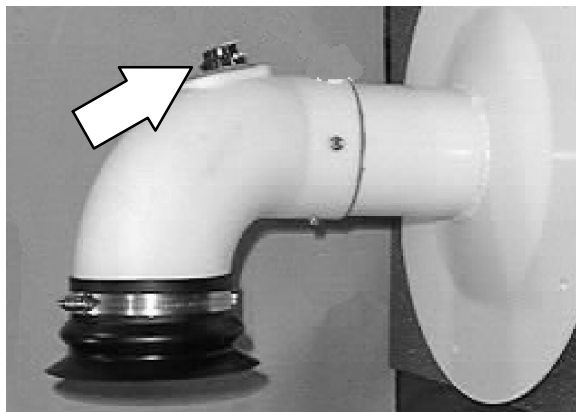

ELECTRICAL

4. Remove the two screws and nuts holding the Thermo Sentry™ to the vacuum tube.



5. Install the new Thermo Sentry™ onto the vacuum tube. Reinstall the hardware and hand tighten. Make sure the gasket is installed under the Thermo Sentry™.

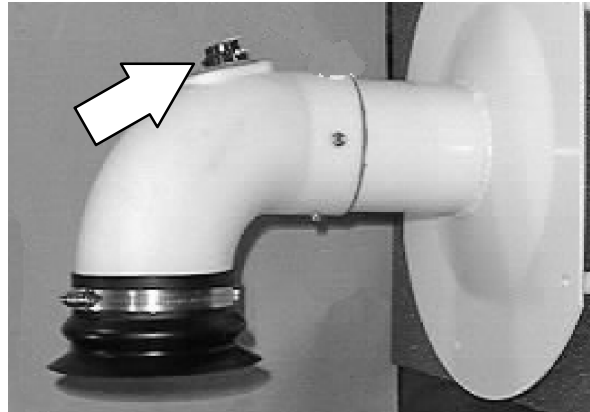

6. Reconnect the wires to the Thermo Sentry™.

7. Reinstall the hopper cover.

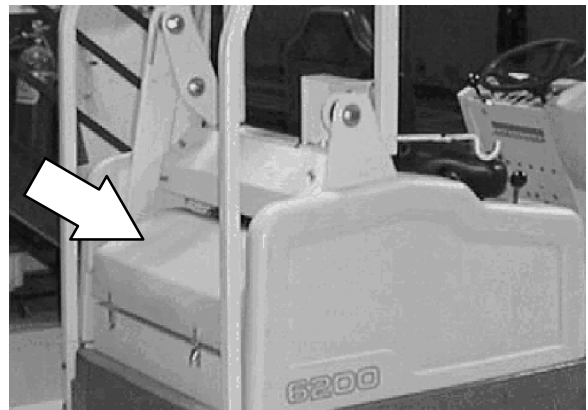

ELECTRICAL SCHEMATIC (00000-002089)

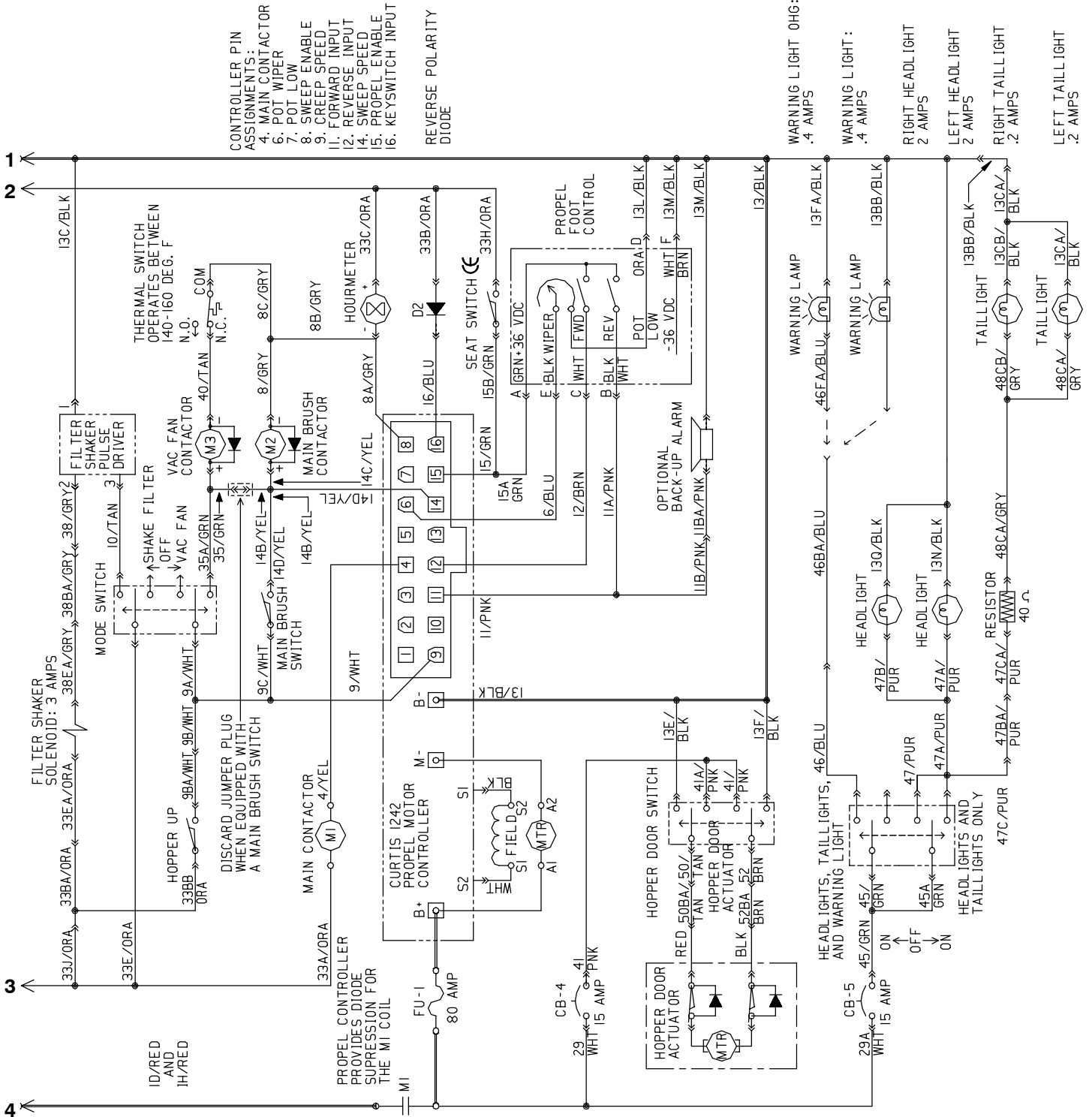

- CONTROLLER PIN ASSIGNMENTS:
- 4. MAIN CONTACTOR
 - 6. POT WIPER
 - 7. POT LOW
 - 8. SWEEP ENABLE
 - 9. CREEP SPEED
 - 11. FORWARD INPUT
 - 12. REVERSE INPUT
 - 14. SWEEP SPEED
 - 15. PROPEL ENABLE
 - 16. KEYSWITCH INPUT
- REVERSE POLARITY DIODE

- WARNING LIGHT OHG: .4 AMPS
- WARNING LIGHT: .4 AMPS
- RIGHT HEADLIGHT: 2 AMPS
- LEFT HEADLIGHT: 2 AMPS
- RIGHT TAILLIGHT: .2 AMPS
- LEFT TAILLIGHT: .2 AMPS

MAIN WIRE HARNESS GROUP

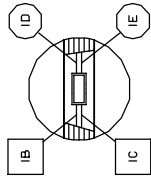

DETAIL D

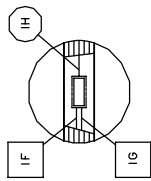

DETAIL C

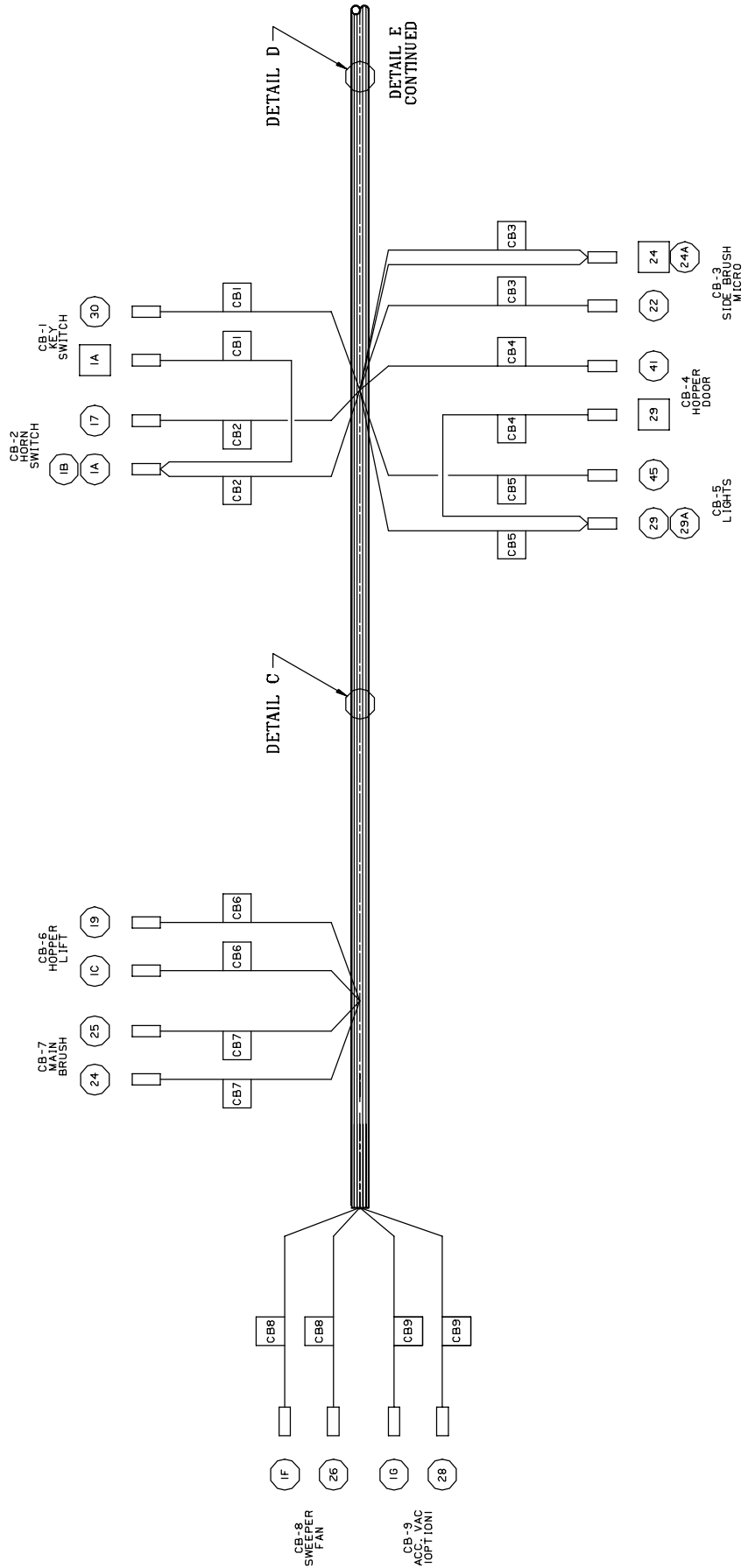

MAIN WIRE HARNESS GROUP

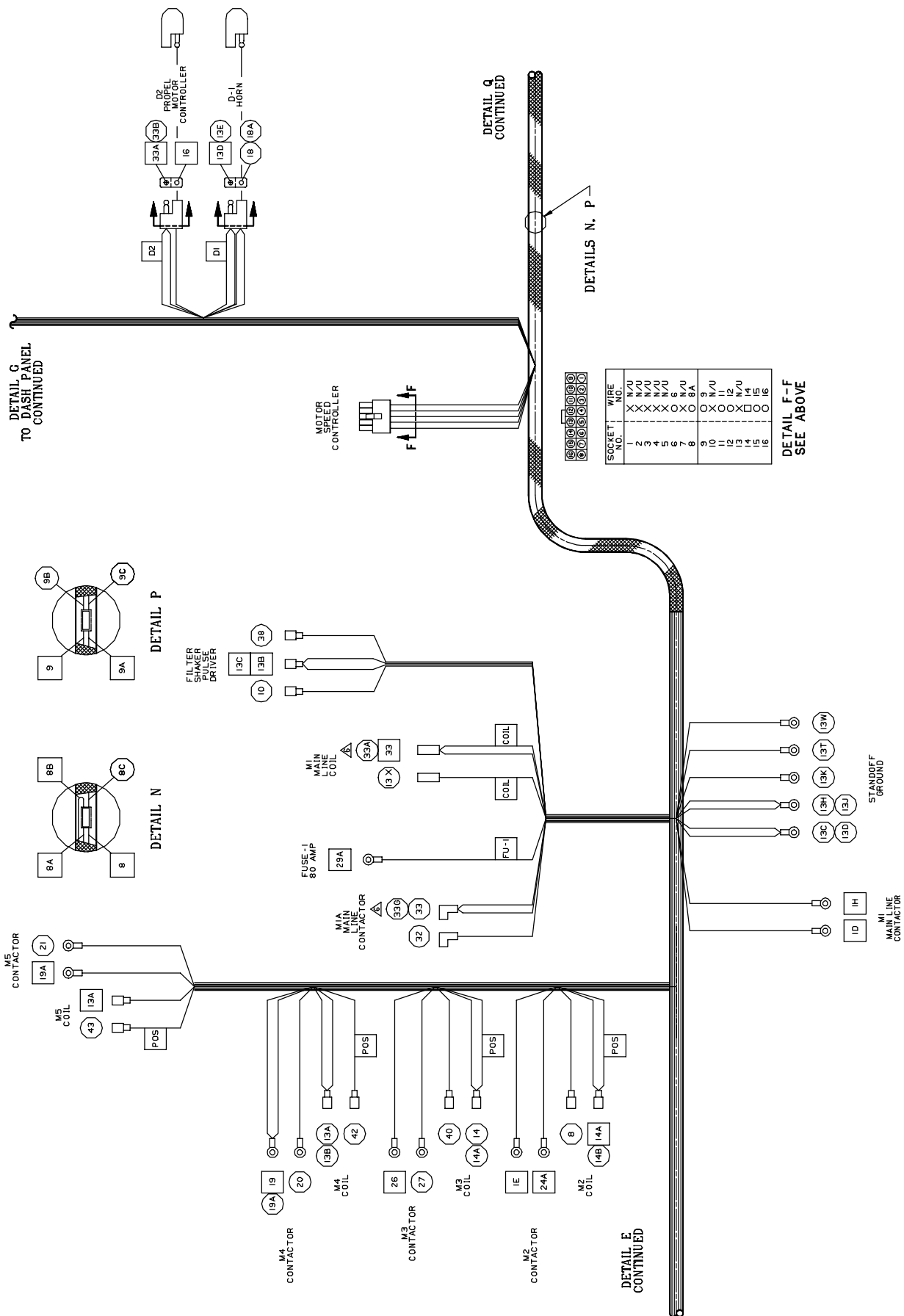

MAIN WIRE HARNESS GROUP

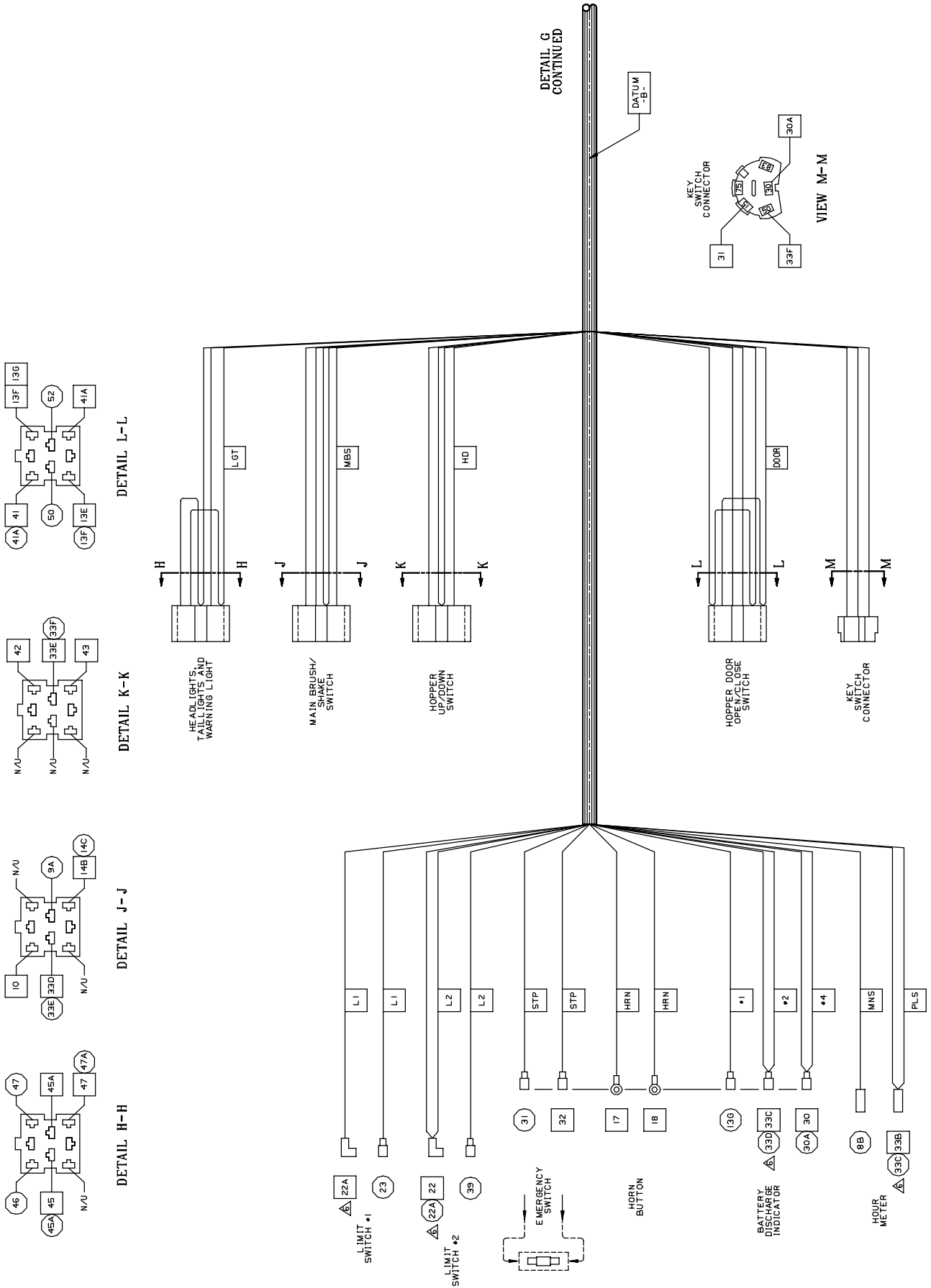

MAIN WIRE HARNESS GROUP

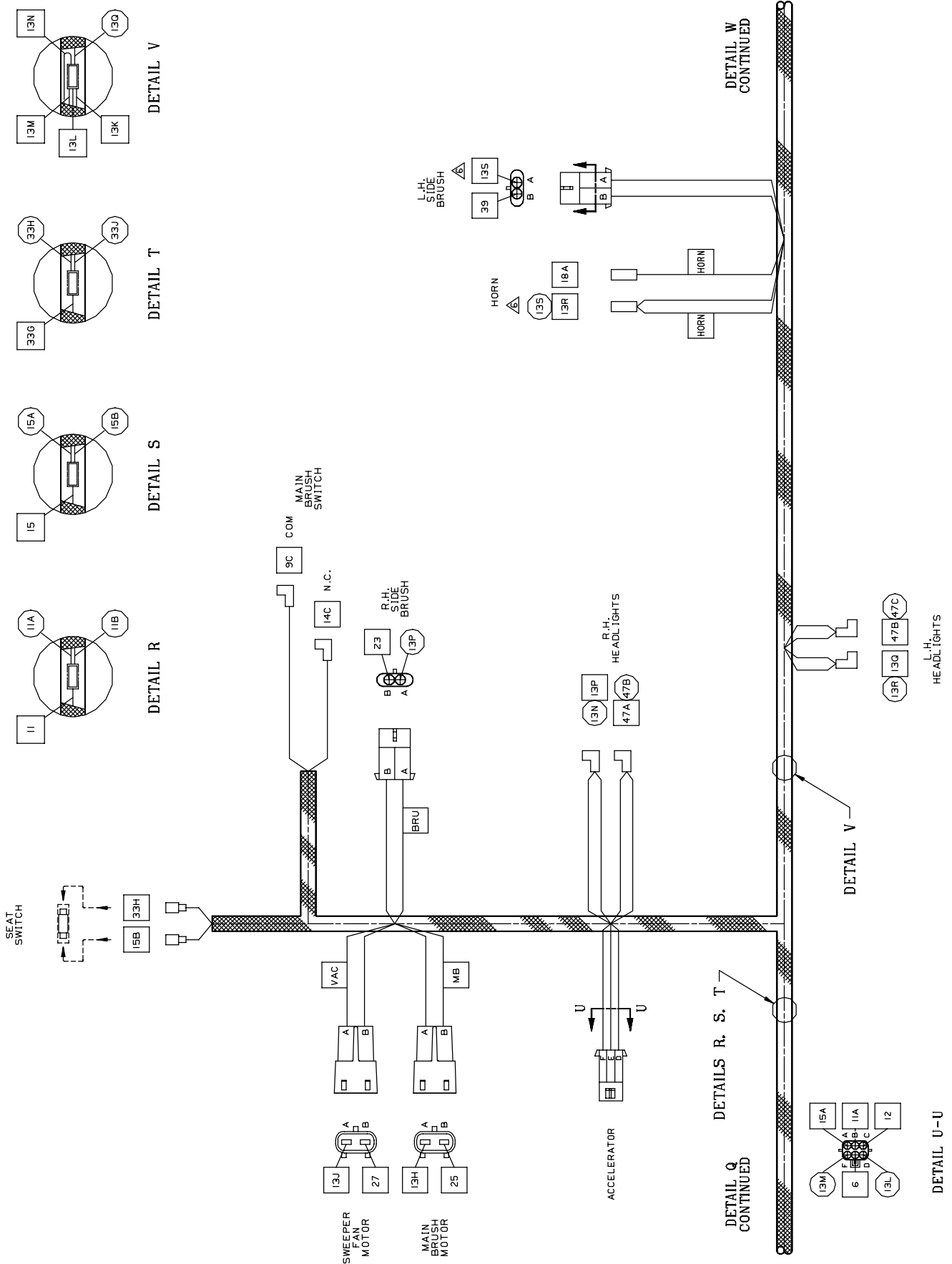

MAIN WIRE HARNESS GROUP

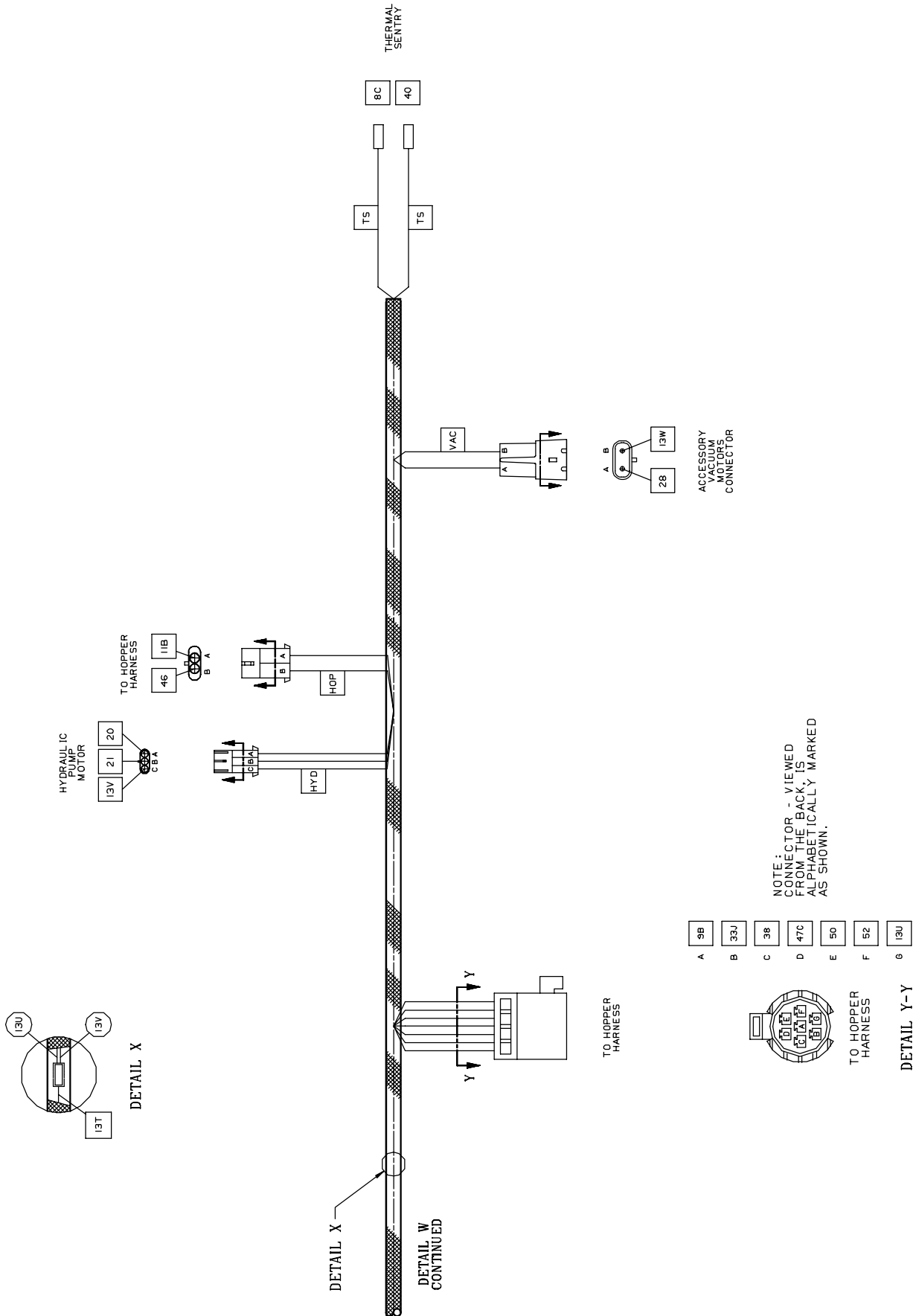

HOPPER WIRE HARNESS GROUP

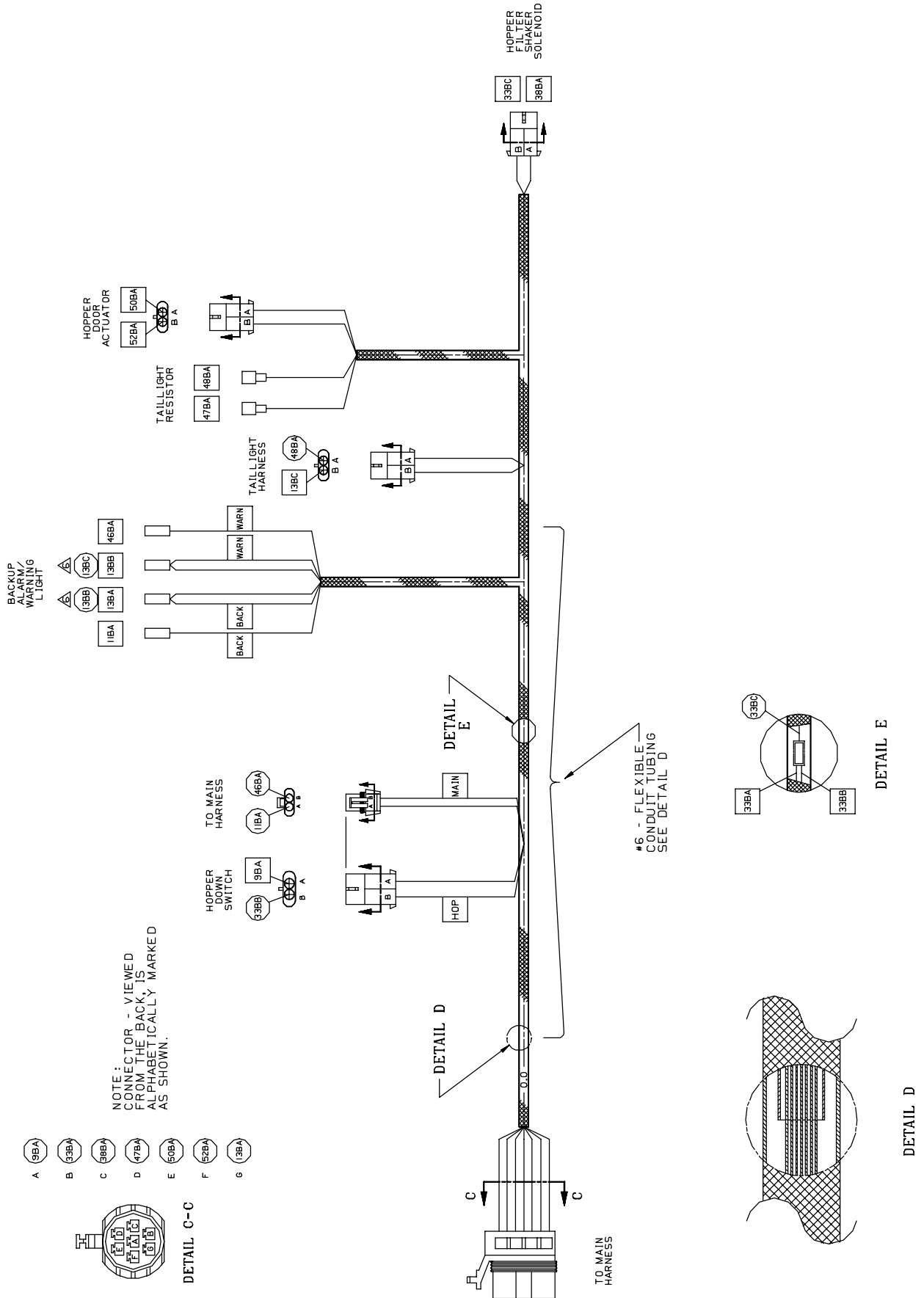

TROUBLESHOOTING

The troubleshooting charts that follow are organized so they lead you through the circuits. They include flow charts and instructions for you as to where to insert your test instruments.

MACHINE START

The main function of the start circuit is to energize the M1 coil to close the power contacts of the M1 main contactor. Without M1 energized, only the horn, optional lighting and accessory vacuum unit will operate.

Electrical components used to start the machine:

CB-1, Key switch, Stop switch, M1 main contactor, 1242 Curtis propel motor controller, M1a auxiliary contact for the M1 contactor, D2 diode.

There are three individual circuits used to energize the M1 contactor:

1. Key switch provides +36 volts to the M1 coil and pin 16 at the motor controller start circuit. (see Fig. 1)

Current flows from battery positive (1/red circuit) to the control circuit breaker CB-1. When the key switch is rotated to the start position, current continues from terminal 50 of the key switch to the reverse polarity diode D1 and finally to pin 16 at the propel motor controller. The M1 contactor coil also receives +36 volts from the key switch.

2. Propel motor controller provides -36 volts to the M1 coil. (see Fig. 2)

When the propel motor controller receives +36 volts to pin 16 (key switch input), the controller then provides -36 volts to the M1 contactor coil. With 36 volts now across the M1 coil, both the power M1 contact, and the M1a auxiliary contact will close.

3. Key switch run circuit. (see Fig. 3)

Current again flows from the battery positive (1/red) to the control circuit breaker CB1. With the key switch spring returned to the run position, current now travels from terminal 15 of the key switch through the normally closed stop switch, M1a auxiliary contact, and on through the reverse polarity diode D1 to pin 16 at the motor controller. The key switch, stop switch, or the controller may open the run circuit causing the M1 coil to drop out.

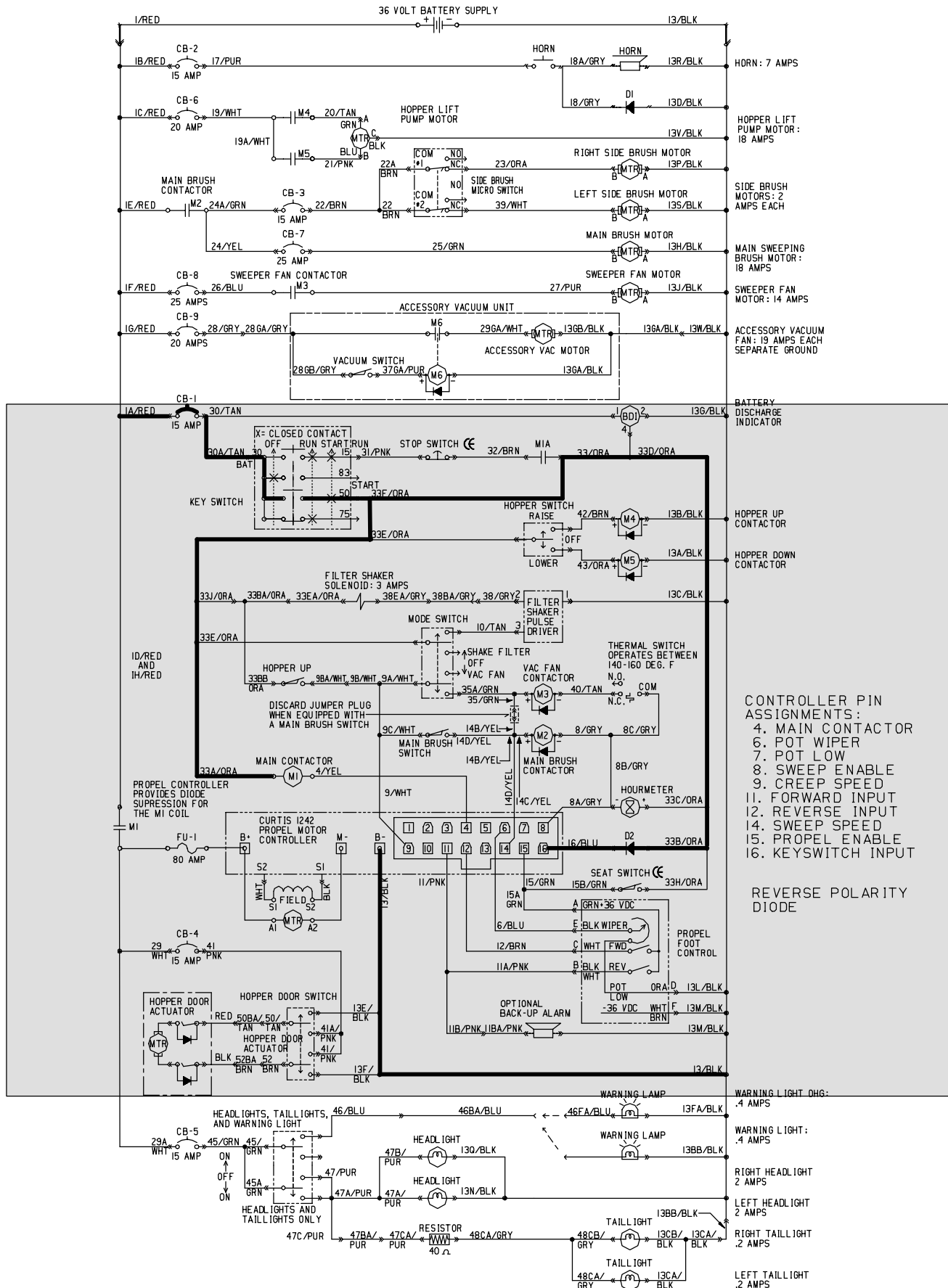

Fig. 1

ELECTRICAL

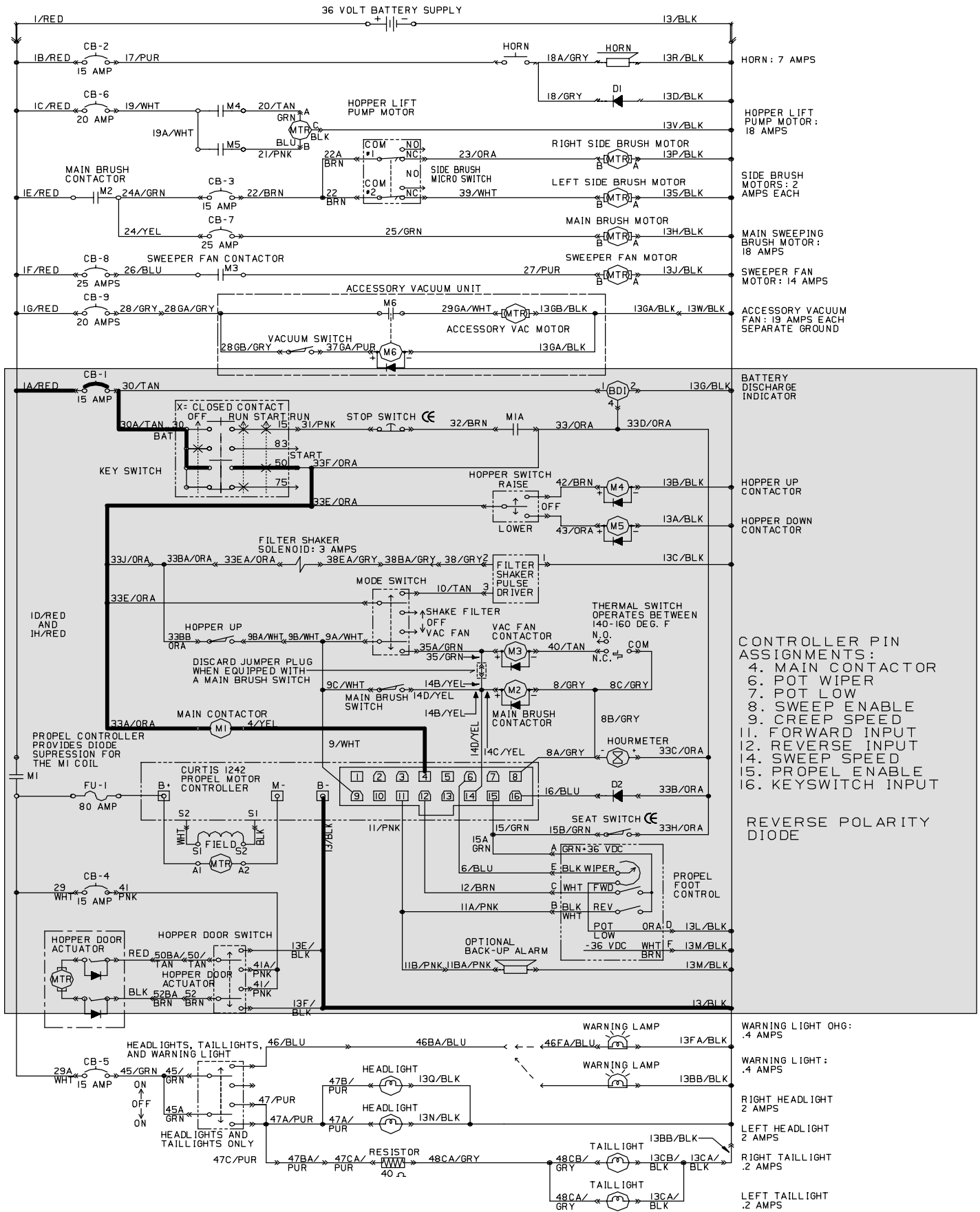
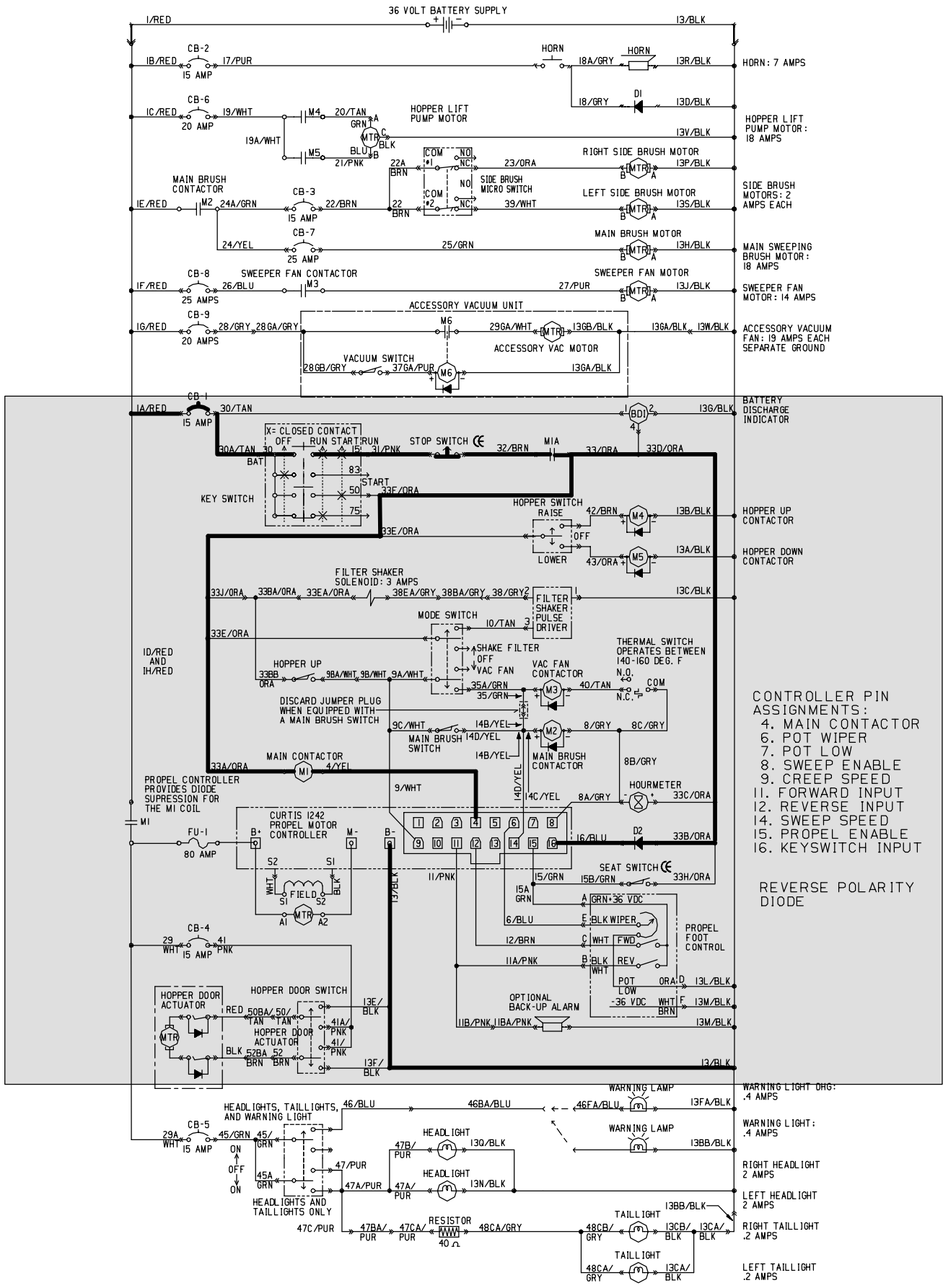

Fig. 2



CONTROLLER PIN ASSIGNMENTS:
 4. MAIN CONTACTOR
 6. POT WIPER
 7. POT LOW
 8. SWEEP ENABLE
 9. CREEP SPEED
 11. FORWARD INPUT
 12. REVERSE INPUT
 14. SWEEP SPEED
 15. PROPEL ENABLE
 16. KEYSWITCH INPUT

REVERSE POLARITY DIODE

Fig. 3

PROPEL MOTOR CIRCUIT

The propel motor controller is used to control the speed and direction of the propel motor. The controller also turns on the hourmeter, main brush motor, and vacuum fan motor while the vehicle is in motion.

Electrical components used to control the propel motor:

M1 main contactor, FU-1 80 amp fuse, 1242 motor controller, Propel motor, Propel foot control, Seat switch.

There are three circuits needed to make the propel motor run:

1. Power Circuit. (see Fig. 4)

*A). **Armature:** Current flows from battery positive to the M1 power contacts, through the 80-amp fuse FU-1, and then to the B+ terminal of the motor controller. Current continues to flow from the B+ terminal to A1 and through the armature of the propel motor. From the negative side of the propel motor A2, current flow continues to M- at the controller. To complete the path back to the battery, the controller uses a transistor like a switch to pulse the connection between M- and B- at the controller. The duty-cycle or on time for each pulse determines the speed of the motor.*

*B). **Field:** The motor controller automatically adjusts the DC current level of the motor wound field to control the torque/speed ratio. The field current profile is programmed into the controller at the factory and is not user adjustable. At lower speeds, the field current is higher to provide more torque. To get higher speed with less torque, the field current is adjusted lower. In addition, the motor controller reverses the polarity of the field current to change direction of the motor rotation.*

2. Direction input signal. (see Fig. 5)

In order to select a direction, the controller requires a +36 volt input to terminal 12 for a forward command or +36 volts to terminal 11 for a reverse command. The signal originates from two solid state switches in the foot pedal control. The foot pedal control at terminal A (green wire) receives +36 volts from the key switch circuit and is fed into the solid state directional switches. As the foot pedal is rotated forward from the center position, the forward switch closes sending +36 volts out terminal C (white wire) of the foot control to terminal 12 at the motor controller. For reverse direction, +36 volts leaves the foot pedal control from terminal B (black/white wire) and is fed into terminal 11 at the motor controller.

3. Speed reference input signal. (see Fig. 6)

The motor controller uses a 0-5 volt signal at terminal 6 at the motor controller. To determine the speed of the propel motor.

4. Mode select inputs. (see Fig. 7)

The propel controller is programmed to operate in three modes:

- Transport (mode 3)- allows for maximum speed*
- Sweeping (mode 4)- reduces the speed for optimum sweeping*
- Hopper up (mode 1)- reduces the speed when the hopper is raised.*

A). When +36 volts is applied to terminal 9 of the controller (as when the hopper down switch is closed), the maximum speed will be allowed.

B). When +36 volts is applied to terminal 14 of the controller (as when the main brush switch is closed), the maximum speed will be reduced to 4.5 MPH.

C). When +36 volts is applied to neither terminal 9 or 14 of the controller the maximum speed will be reduced to 3 MPH.

ELECTRICAL

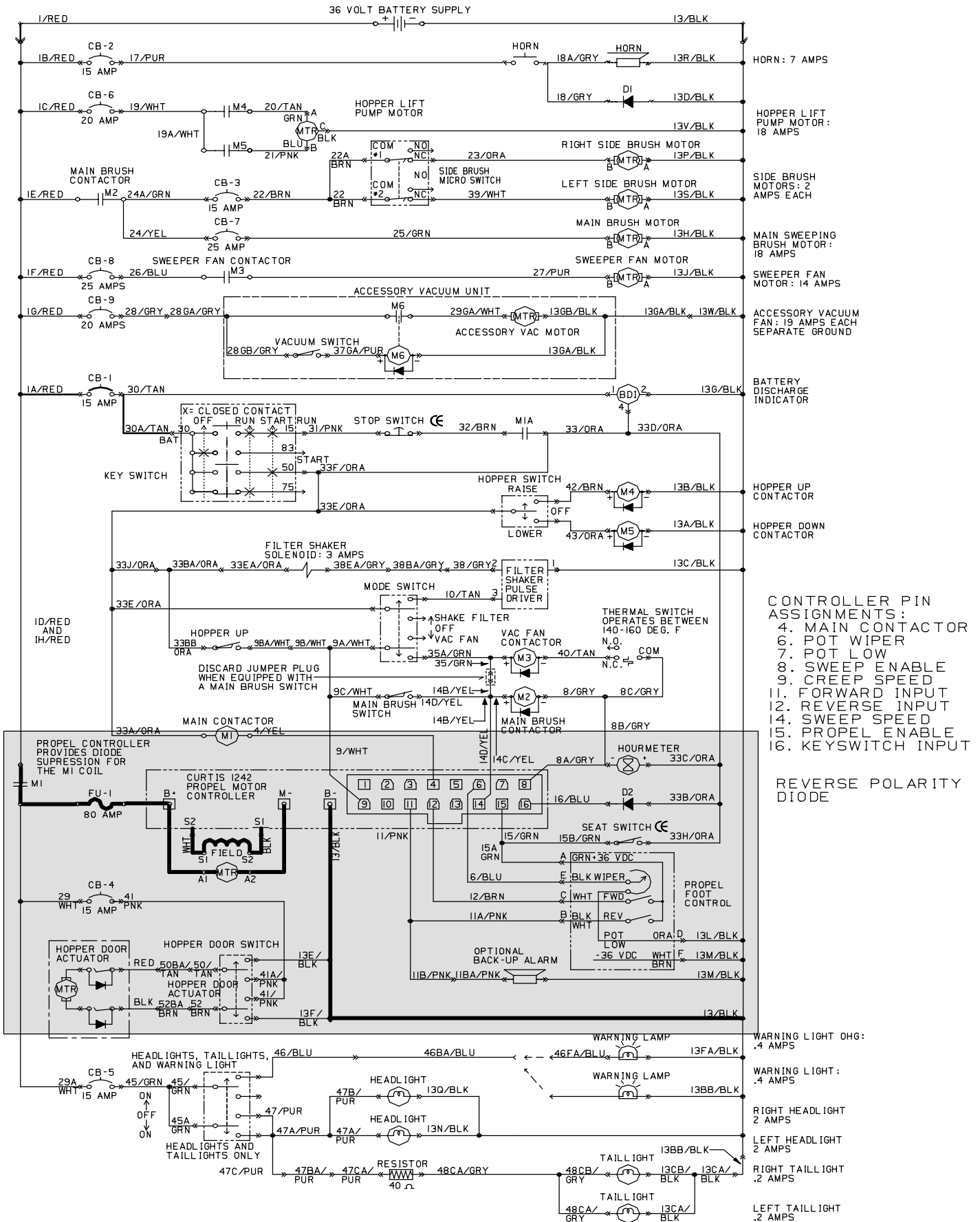

Fig. 4

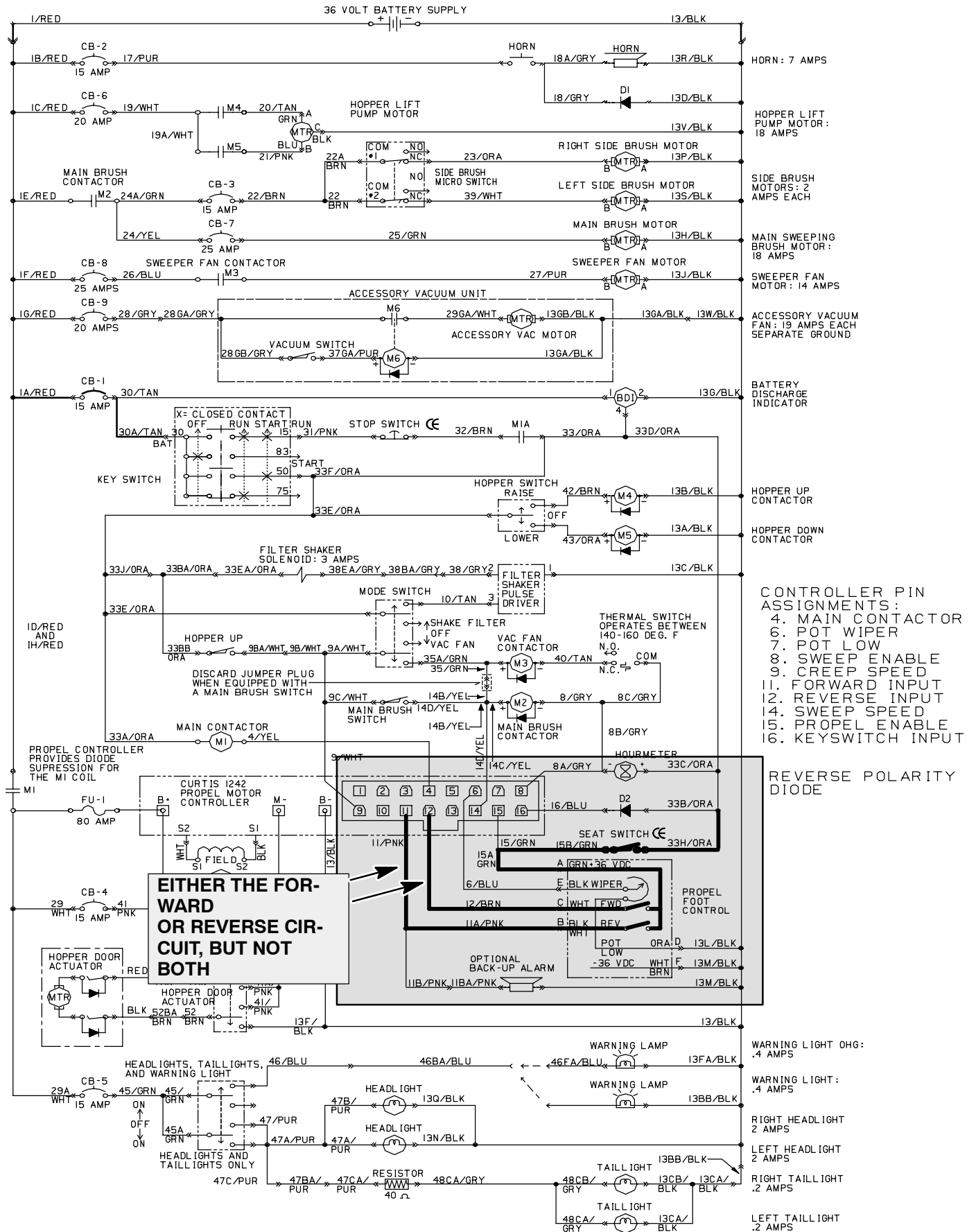
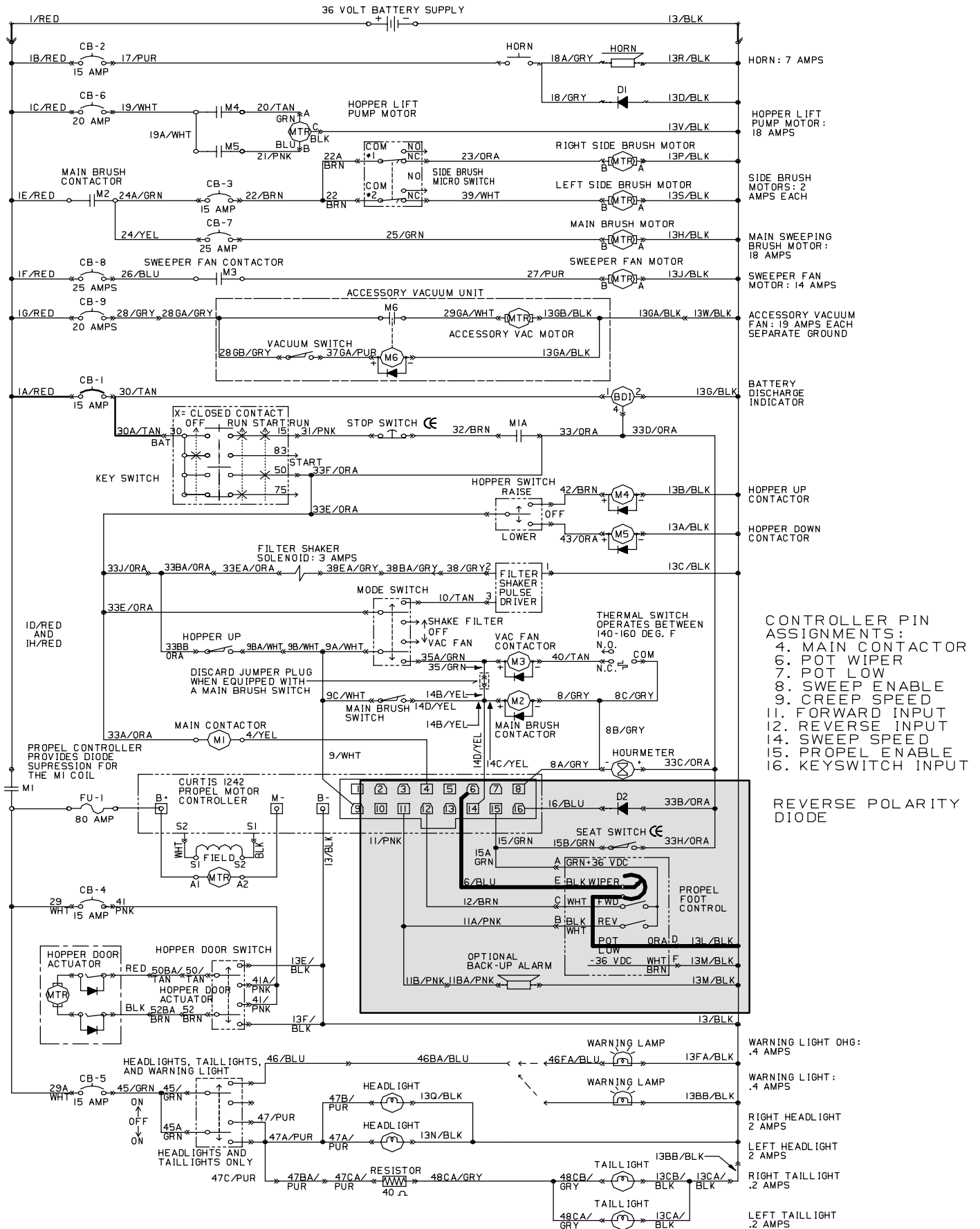

Fig 5

ELECTRICAL



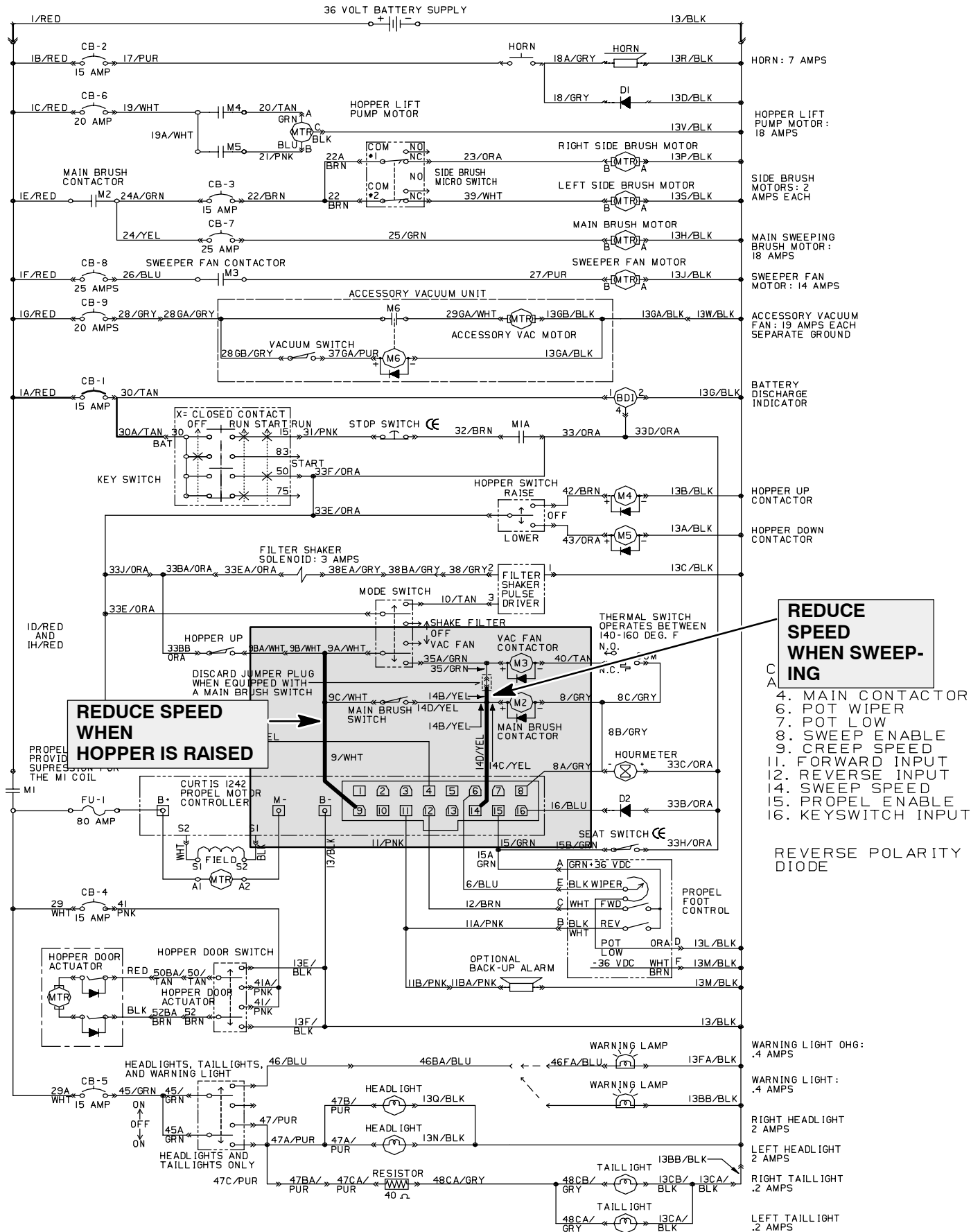

Fig. 7

ELECTRICAL

PROPEL MOTOR CONTROLLER DIAGNOSTICS AND TROUBLESHOOTING GUIDE:

LED Code	Explanation	Possible Cause
@ @	Current sensor error	Controller defective
@ @@	Hardware fail-safe error	Controller defective
@ @@@	Internal M- short to B-	Controller defective
@ @@@@	Static return to off fault	1. Improper sequence of KSI, interlock, direction inputs. 2. Wrong SRO type Programmed. 3. Interlock or direction switch circuit open. 4. Sequencing delay too short.
@@ @	Pot wiper fault	1. Throttle input wires open or shorted to B+ or B-. 2. Throttle pot defective 3. Incorrect throttle type used or programmed
@@ @@	Emergency rev wiring fault	Emergency reverse wire or check wire open
@@ @@@	High pedal disable fault/	1. Improper sequence of KSI, interlock, direction inputs. 2. Wrong HPD type programmed. 3. Misadjusted throttle pot. 4. Sequencing delay too short.
@@ @@@@	Pot low wire open or shorted	Throttle pot wire broken or shorted. Wrong throttle type installed or programmed.
@@@ @	Contactor coil output driver overcurrent or field short	1. Main contactor coil shorted. 2. Field winding Shorted.
@@@ @@	Welded main contactor	1. Main contactor stuck closed. 2. Main contactor output shorted.
@@@ @@@	Motor field winding open	Field winding or its connection is open.
@@@ @@@@	Missing contactor connections	1. Main contactor coil is open, or contactor missing. 2. Wire to main contactor is open.
@@@@ @	Low battery voltage	1. Battery voltage < cutback limit. 2. Corroded battery terminal. 3. Loose battery or controller terminal./
@@@@ @@	Overvoltage	1. Battery voltage is > shutdown limit. 2. Vehicle operating with charger attached.
@@@@ @@@	Over or under-temperature cutback	1. Temperature > 85(C or < -25(C. 2. Excessive load on the vehicle. 3. Improper mounting of the controller. 4. Operation in extreme environments.
@@@@ @@@@	Mode 2 or Mode 4 selected at start-up	1. Mode 2 or Mode 4 selected at start-up/Mode switches 2. shorted to B+. 3. Mode switches enabled at start-up.

MAIN SWEEPING BRUSH

The main sweeping brush motor will only operate when the hopper is down, main brush lowered, and the vehicle is in motion.

Electrical components needed to operate the main brush motor circuit:

CB-1, Key switch, Stop switch, M1 main contactor, M1a auxiliary contact, 1242 Curtis motor controller, Hopper down switch, Main brush switch, M2 main brush contactor, Main brush motor.

1. Control circuit. (see fig. 8)

For the main sweeping brush motor to operate, the machine must be started with the M1 contactor energized. The hopper should be lowered completely allowing the hopper down switch to close. Engaging the main brush lever closes the main brush switch and provides +36 volts to the (+) terminal of the main brush contactor coil. Finally, when the machine is commanded to move from the propel foot control, the controller completes the circuit with -36 volts from pin 8 of the motor controller to the (-) coil terminal of the main brush contactor M2.

2. Power circuit. (see fig. 9)

When the M2 contactor is energized, current flows through the M2 contacts, CB-7, and finally the main brush motor.

ELECTRICAL

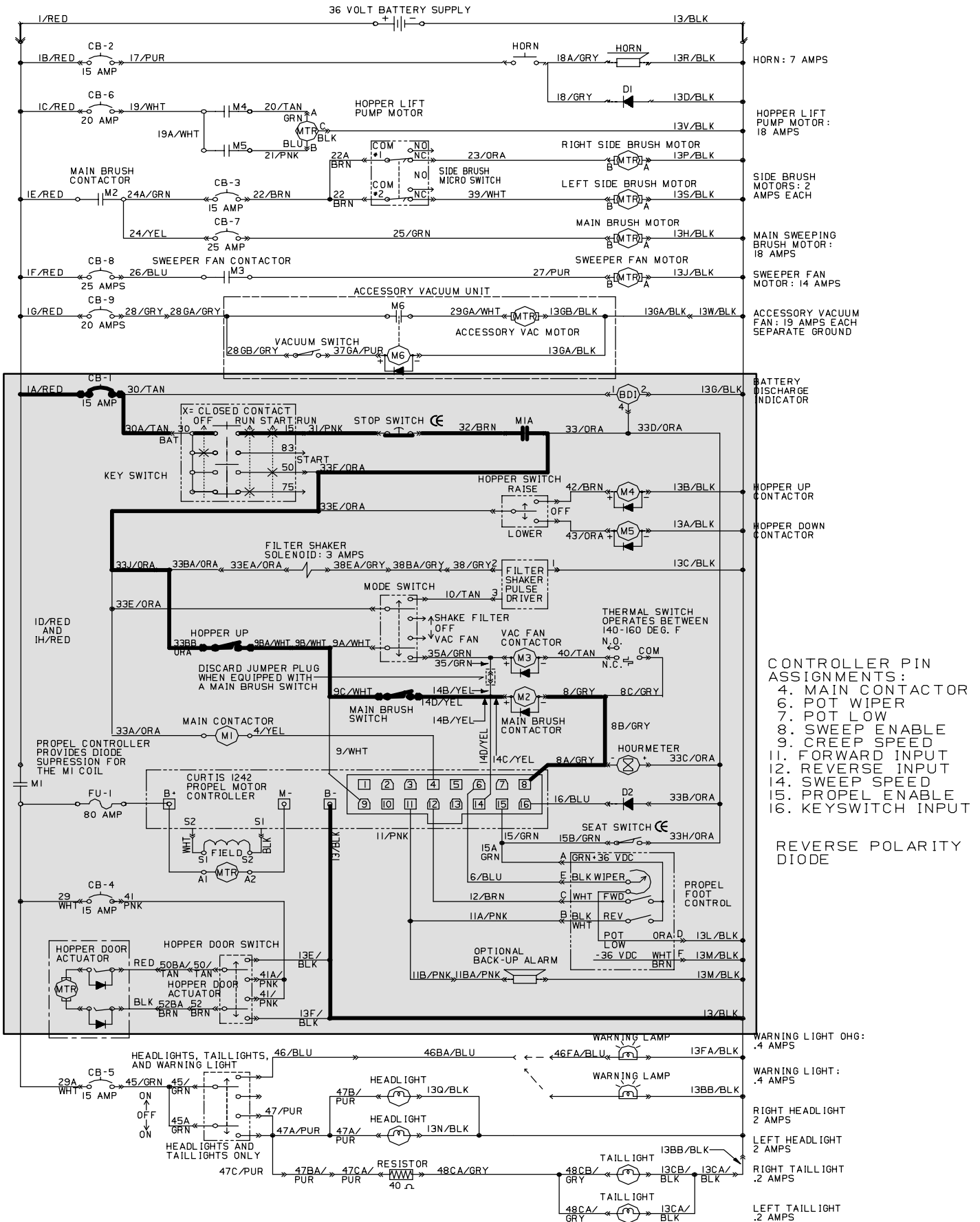

Fig. 8

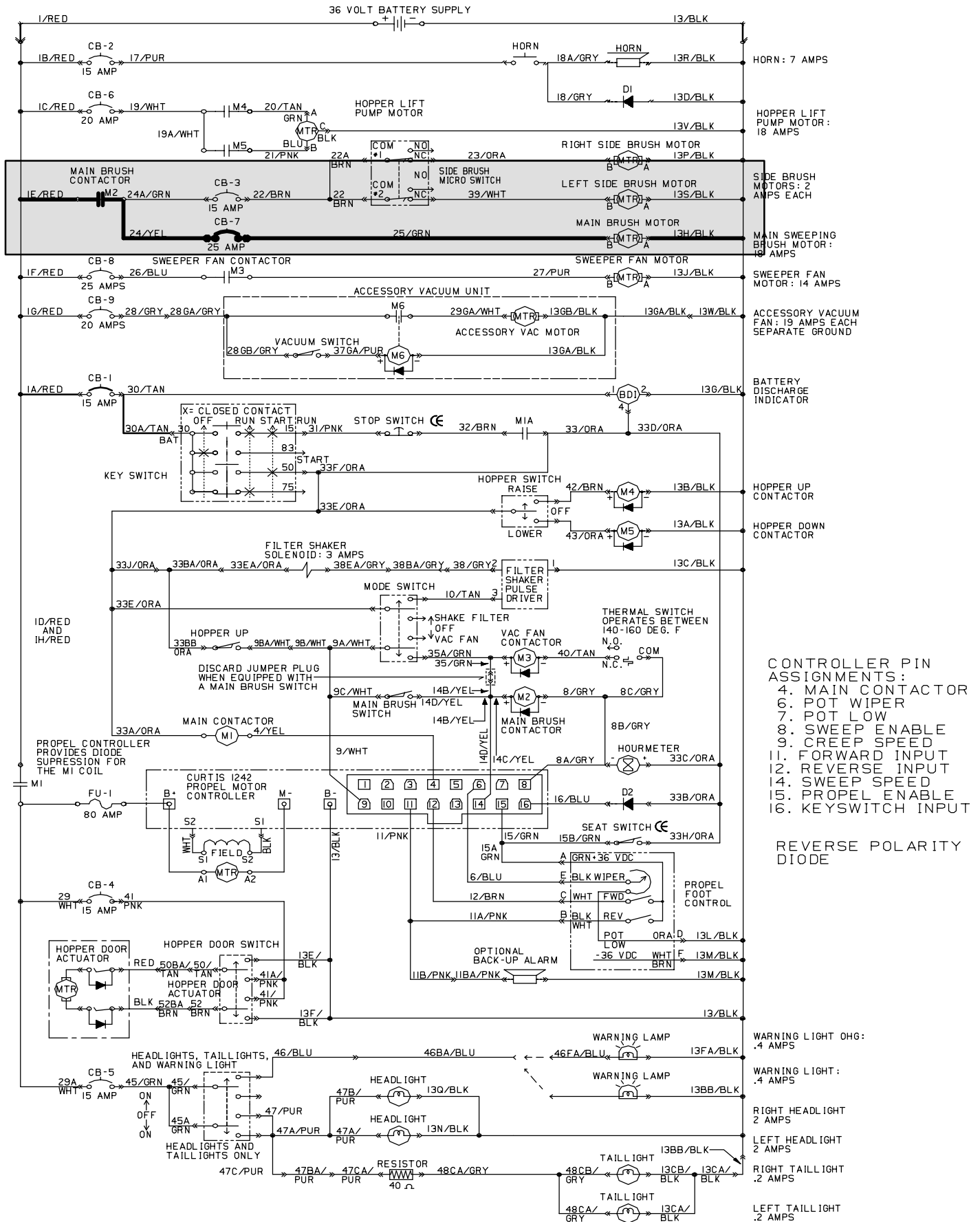

Fig. 9

VACUUM FAN MOTOR

The vacuum fan motor will only operate when the hopper is down, fan/shake filter rocker switch is in the fan position, and the vehicle is in motion.

Electrical components needed to operate the vacuum fan motor circuit:

CB-1, Key switch, Stop switch, M1 main contactor, M1a aux. contact, 1242 motor controller, Fan/shake filter switch, CB-8, M3 brush contactor, Main brush motor.

1. Control circuit. (see fig. 10)

For the vacuum fan motor to operate, the machine must be started with the M1 contactor energized. The hopper should be lowered completely allowing the hopper down switch to close. Engaging the Fan/shake filter rocker switch in the fan position provides +36 volts to the (+) terminal of the vacuum fan contactor coil. Finally, when the machine is commanded to move from the propel foot control, the controller completes the circuit with -36 volts from pin 8 of the motor controller to the (-) coil terminal of the vacuum fan contactor M3.

2. Power circuit. (see fig. 11)

When the M3 contactor is energized, current flows through CB-7, the M3 contacts, and finally the vacuum fan motor.

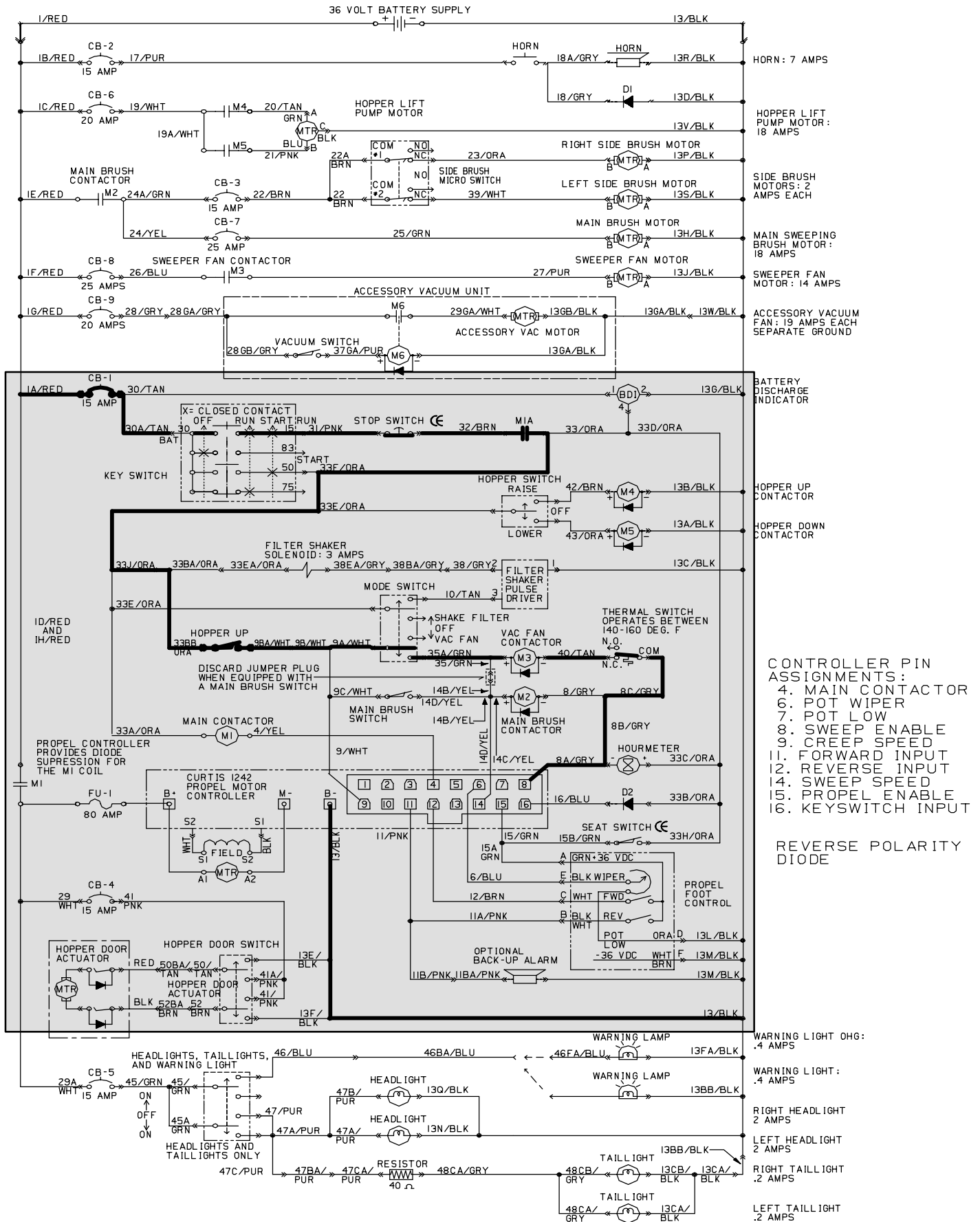

Fig. 10

ELECTRICAL

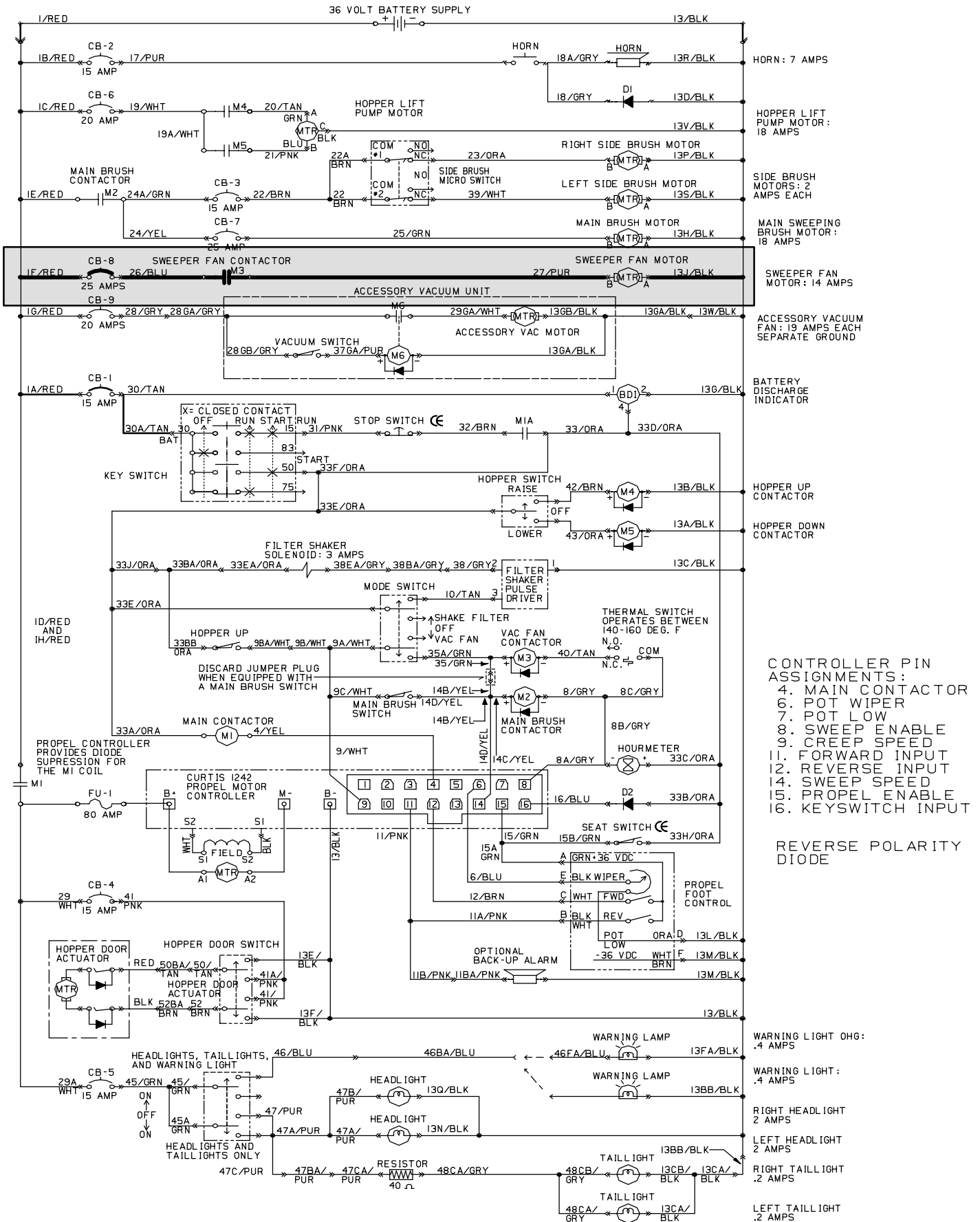

Fig. 11

FILTER SHAKER

The vacuum fan motor will only operate when the machine is started and the fan/shake filter rocker switch is held in the shake filter position.

Electrical components needed to operate the filter shaker solenoid:

CB-1, Key switch, Stop switch, M1 main contactor, M1a aux. contact, 1242 motor controller, Fan/shake filter switch, Filter shaker pulse driver, Filter shaker solenoid

1. Control circuit. (see fig. 12)

For the vacuum fan motor to operate, the machine must be started with the M1 contactor energized. The hopper should be lowered completely allowing the hopper down switch to close. Engaging the Fan/shake filter rocker switch in the fan position provides +36 volts to the (+) terminal of the vacuum fan contactor coil. Finally, when the machine is commanded to move from the propel foot control, the controller completes the circuit with -36 volts from pin 8 of the motor controller to the (-) coil terminal of the vacuum fan contactor M3.

2. Power circuit. (see fig. 13)

When the M3 contactor is energized, current flows through CB-7, the M3 contacts, and finally the vacuum fan motor.

ELECTRICAL

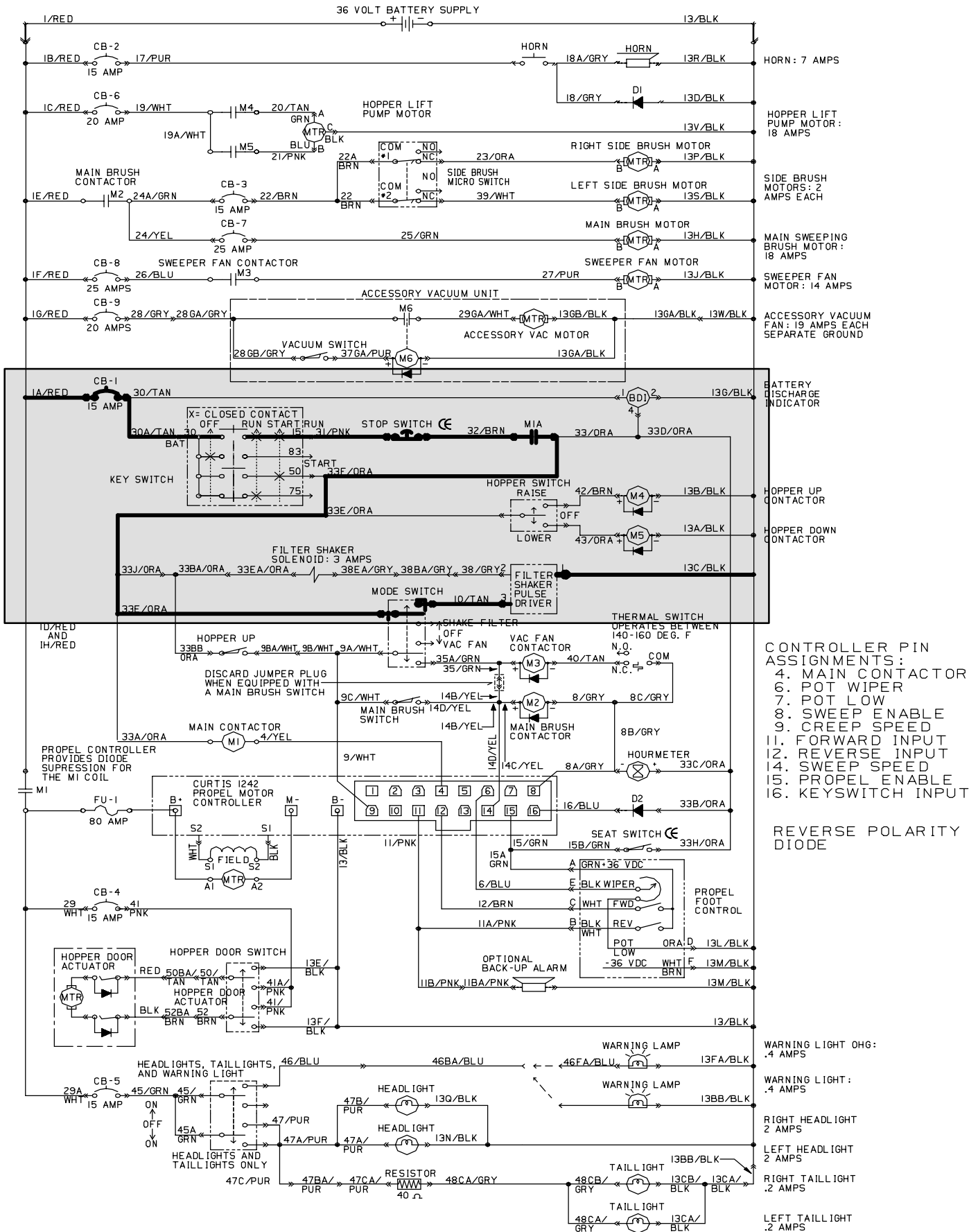

Fig. 12

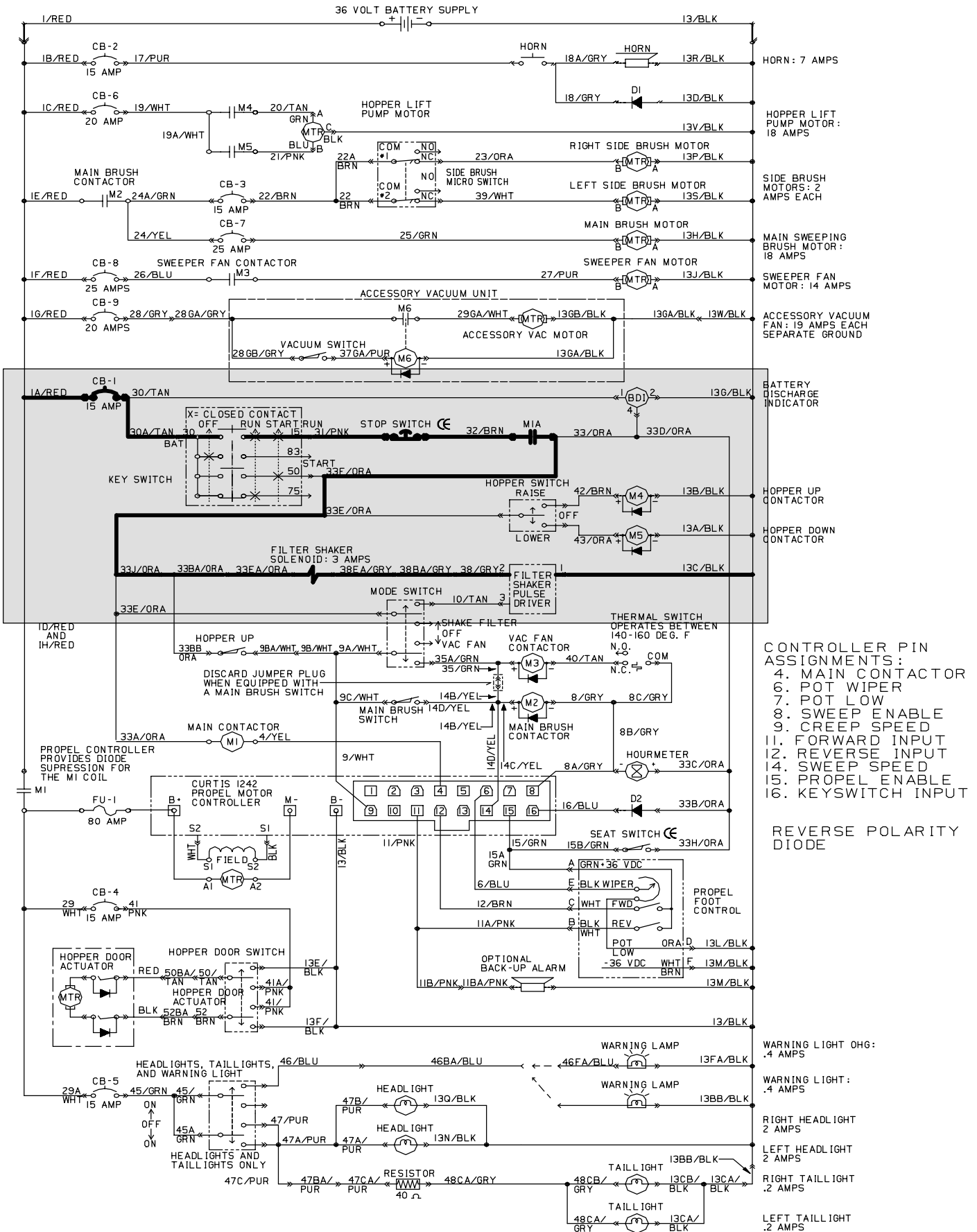

Fig. 13

CONTENTS

	Page
INTRODUCTION	5-3
HYDRAULIC FLUID RESERVOIR	5-4
HYDRAULIC FLUID	5-4
HYDRAULIC HOSES	5-5
TO REPLACE HOPPER LIFT CYLINDER .	5-6
TO REPLACE ELECTRO/HYDRAULIC LIFT UNIT	5-9
HYDRAULIC TROUBLESHOOTING	5-12
HYDRAULIC SCHEMATIC	5-13
HYDRAULIC HOSE GROUP	5-14

INTRODUCTION

The hydraulic system on the model 6200E consists of the electro/hydraulic pump, reservoir, hoses, and hopper lift cylinder.

HYDRAULIC FLUID RESERVOIR

The reservoir is located behind the hopper compartment, under.

A filler cap is mounted on top of the reservoir.

Check the hydraulic fluid level at operating temperature after every 100 hours of operation. Make sure the hopper support bar is in place before checking hydraulic fluid level. The side of the reservoir is marked with FULL and ADD levels to indicate the level of hydraulic fluid in the reservoir.

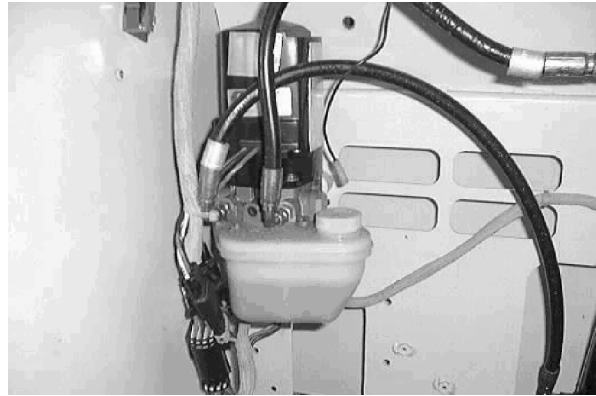

ATTENTION! Do not overfill the hydraulic fluid reservoir or operate the machine with a low level of hydraulic fluid in the reservoir. Damage to the machine hydraulic system may result.

Drain and refill the hydraulic fluid reservoir with new hydraulic fluid after every 800 hours of operation.

The hydraulic fluid filter is located under the engine compartment. Replace the filter element after every 800 hours of operation.

The reservoir has a built-in strainer outlet that filters hydraulic fluid before it enters the system. Replace the strainer after every 800 hours of operation.

HYDRAULIC FLUID

The quality and condition of the hydraulic fluid play a very important role in how well the machine operates. Tennant's hydraulic fluid is specially selected to meet the needs of Tennant machines.

Tennant's hydraulic fluids provide a longer life for the hydraulic components. There are two fluids available for different temperature ranges:

Tennant hydraulic fluid	
Part number	Ambient temperature
65869	above 7° C (45° F)
65870	below 7° C (45° F)

The higher temperature fluid has a higher viscosity and should not be used at the lower temperatures. Damage to the hydraulic pumps may occur because of improper lubrication.

The lower temperature fluid is a thinner fluid for colder temperatures.

If a locally available hydraulic fluid is used, make sure the specifications match Tennant hydraulic fluid specifications. Using substitute fluids can cause premature failure of hydraulic components.

ATTENTION! Hydraulic components depend on system hydraulic fluid for internal lubrication. Malfunctions, accelerated wear, and damage will result if dirt or other contaminants enter the hydraulic system.

HYDRAULIC HOSES

Check the hydraulic hoses after every 800 hours of operation for wear or damage.

Fluid escaping at high pressure from a very small hole can be almost invisible, and can cause serious injuries.

See a doctor at once if injury results from escaping hydraulic fluid. Serious infection or reaction can develop if proper medical treatment is not given immediately.

FOR SAFETY: When servicing machine, use cardboard to locate leaking hydraulic fluid under pressure.

If you discover a fluid leak, contact your mechanic or supervisor.

The hydraulic reservoir on the model 6200E is located on the bottom of the electro/hydraulic unit.

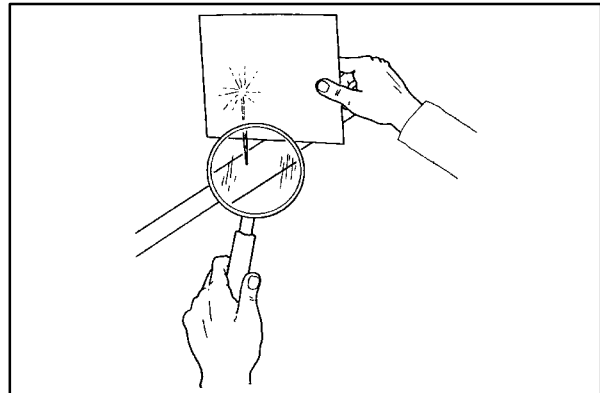

00002

HYDRAULICS

TO REPLACE HOPPER LIFT CYLINDER

FOR SAFETY: Before Leaving Or Servicing Machine; Stop On Level Surface, Set Parking Brake, Turn Off Machine And Remove Key.

1. Un-latch and remove the hopper filter cover.

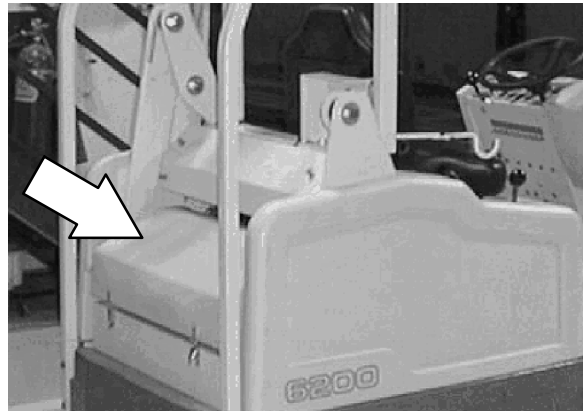

2. Locate the hopper lift cylinder at the rear, center of the machine.

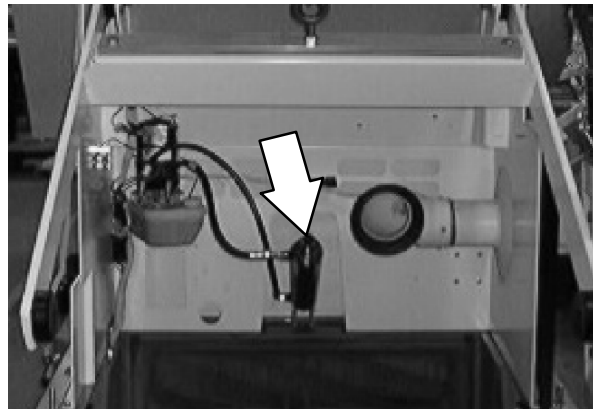

3. Mark, disconnect, and plug the two hoses leading to the lift cylinder.

NOTE: Observe hydraulic cleanliness requirements when opening hydraulic lines.

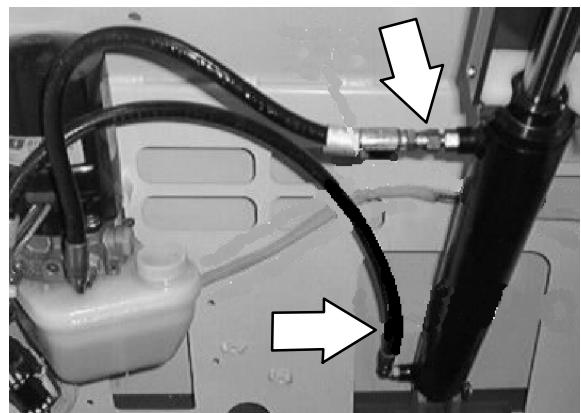

4. Remove the upper cotter pin and clevis pin from the hopper lift cylinder.

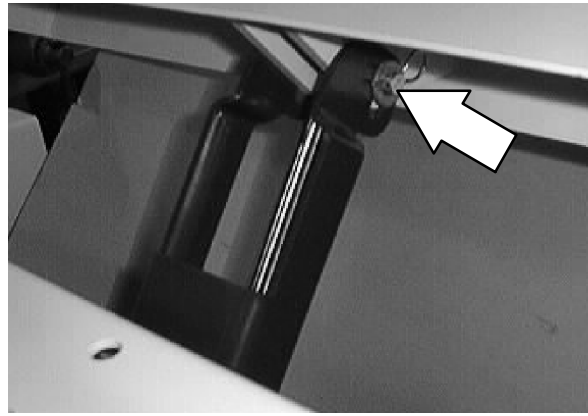

5. Remove the lower cotter pin and clevis pin from the hopper lift cylinder. Remove the lift cylinder from the machine.



6. Remove the hydraulic fittings from the existing lift cylinder and install in the new cylinder in the same orientation.

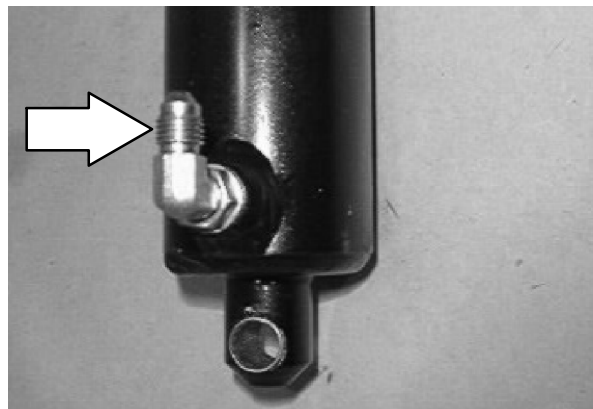

7. Install the new lift cylinder into the machine. Reinstall the upper and lower clevis pins and cotter pins.

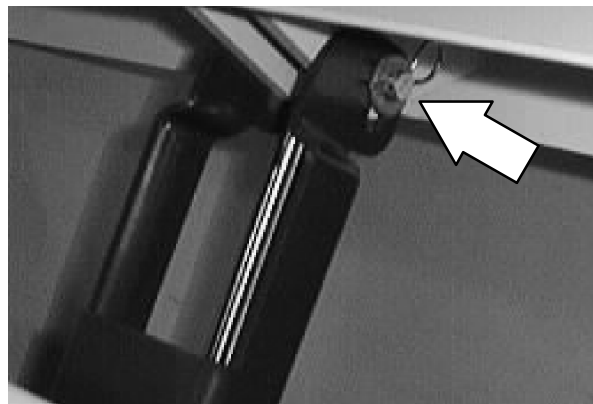

HYDRAULICS

8. Reconnect the two hydraulic hoses to the new hopper lift cylinder.

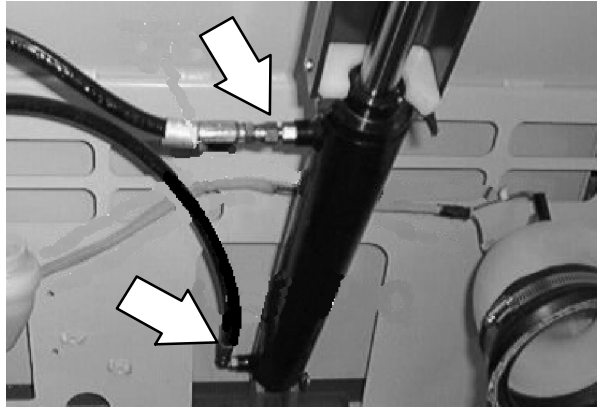

9. Reinstall the hopper cover and engage both latches.

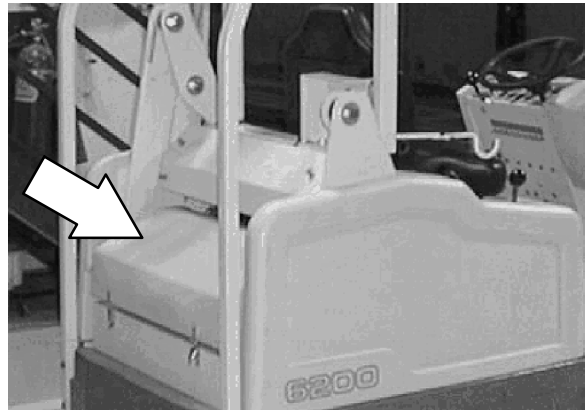

10. Operate the machine. Check the new hopper lift cylinder for proper operation.

TO REPLACE ELECTRO/HYDRAULIC LIFT UNIT

FOR SAFETY: Before Leaving Or Servicing Machine; Stop On Level Surface, Set Parking Brake, Turn Off Machine And Remove Key.

1. Un-latch and remove the hopper filter cover.

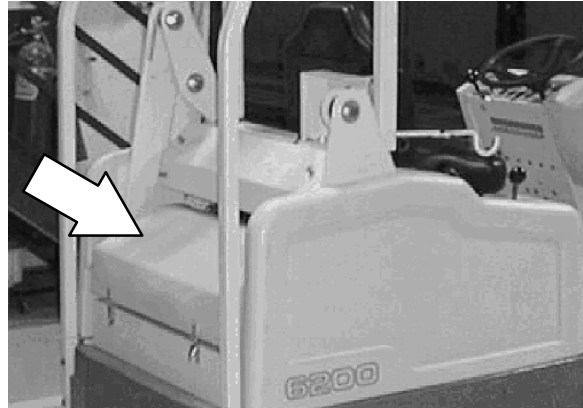

2. Locate the hopper lift electro/hydraulic unit at the rear, left side of the machine.

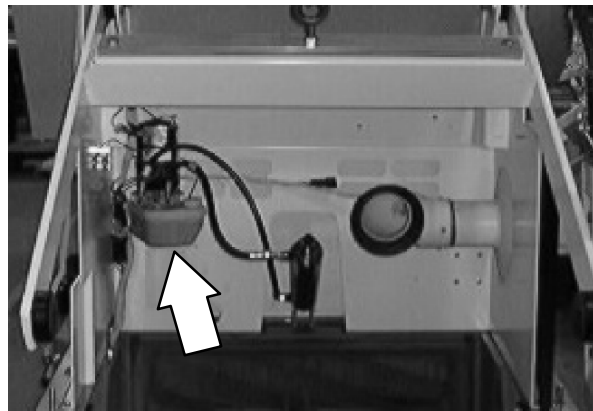

3. Mark, disconnect, and plug the two hoses leading to the hopper lift electro/hydraulic unit.

NOTE: Observe hydraulic cleanliness requirements when opening hydraulic lines.

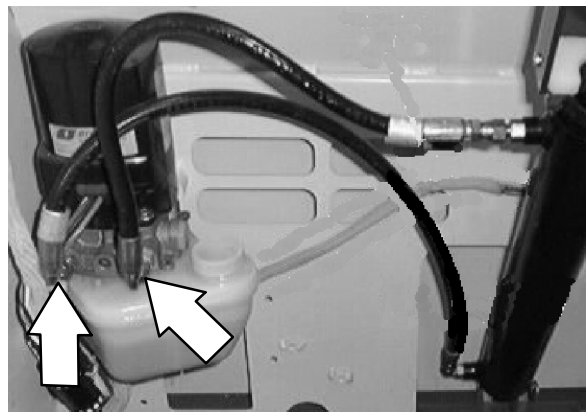

HYDRAULICS

4. Disconnect the hopper lift electro/hydraulic unit from the main harness.

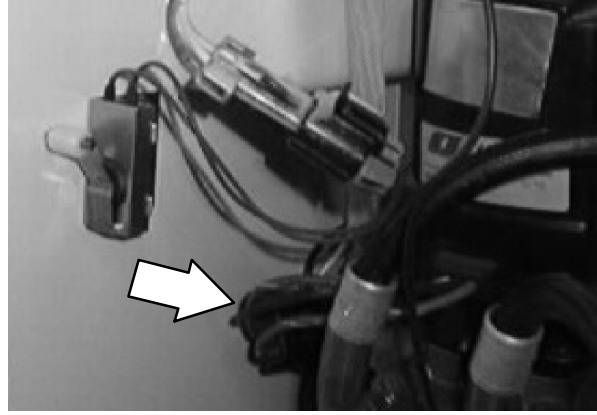

5. Remove the two hex screws holding the electro/hydraulic unit to the lift arm panel. Remove the unit from the machine. Make sure to retain the two spacers.

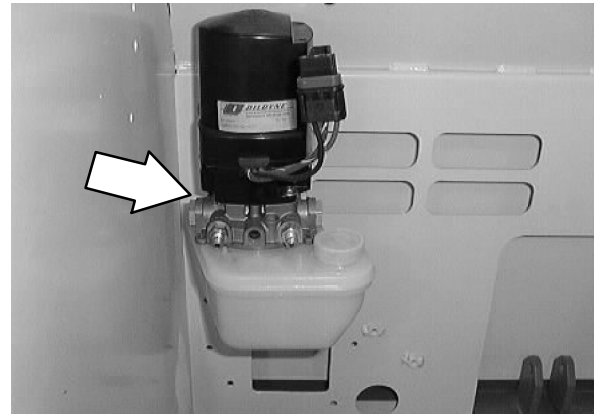

6. Remove the two hydraulic fittings from the existing electro/hydraulic unit. Install the two fittings into the new unit.

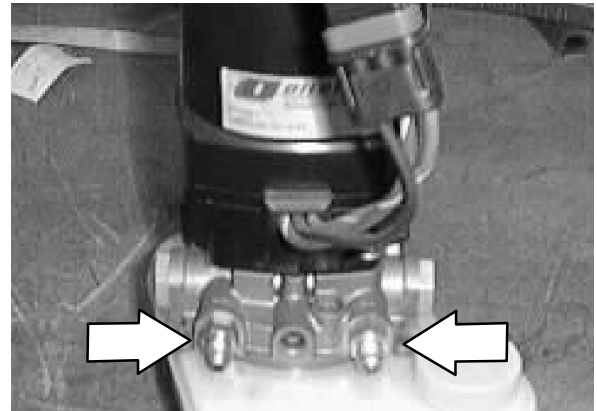

7. Install the new electro/hydraulic unit onto the lift arm panel. Reinstall the two hex screws and spacers (*spacers between unit and panel*). Tighten to 18 - 24 Nm (15 - 20 ft lb).



8. Reconnect the two hydraulic hoses to the new electro/hydraulic unit.

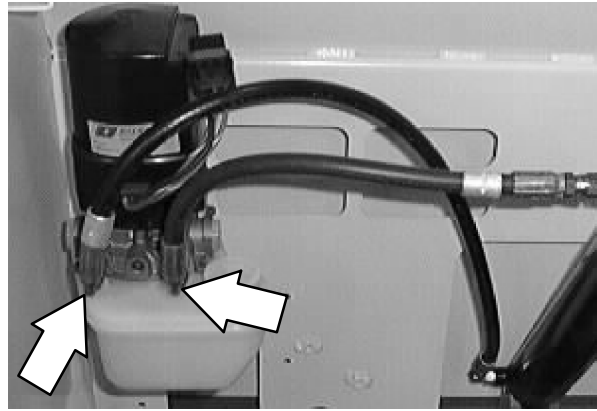

9. Connect the plug from the main electrical harness into the connector from the new unit.

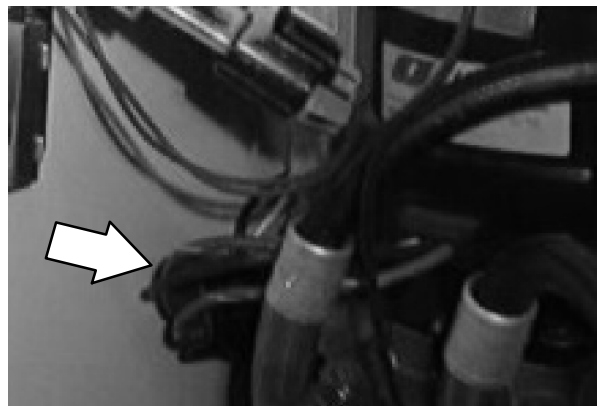

10. Check the hydraulic fluid reservoir tank.

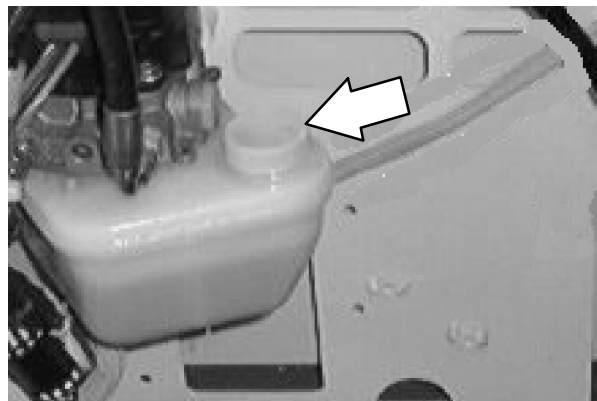

11. Reinstall the hopper cover and engage both latches.

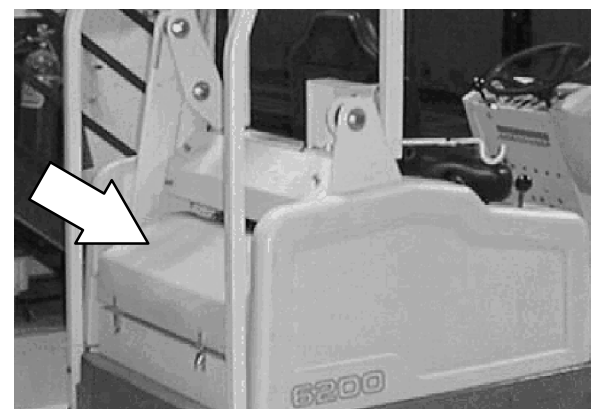

12. Operate the machine. Check the new hopper lift electro/hydraulic unit for proper operation.

HOPPER WILL NOT RAISE/LOWER

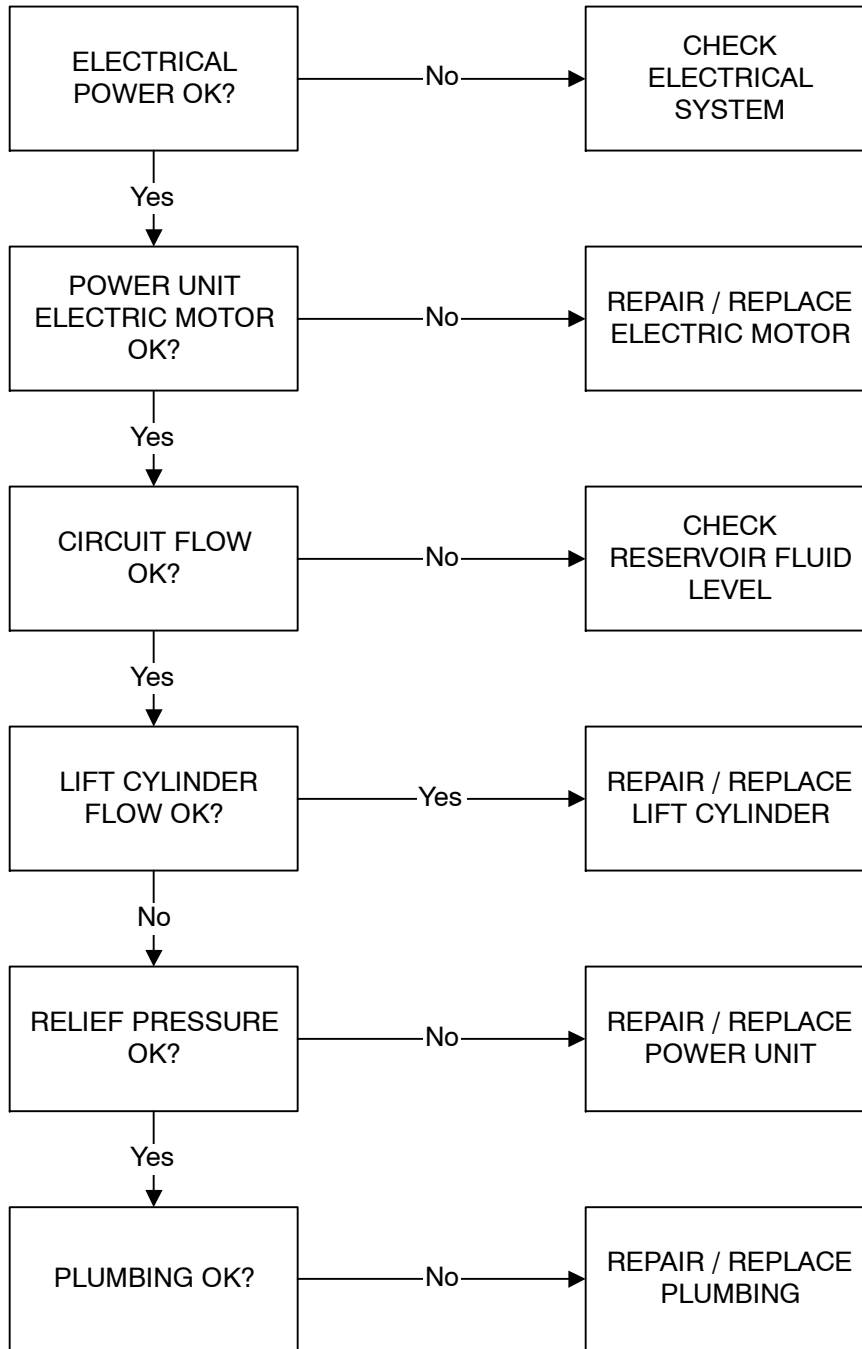

HYDRAULIC SCHEMATIC

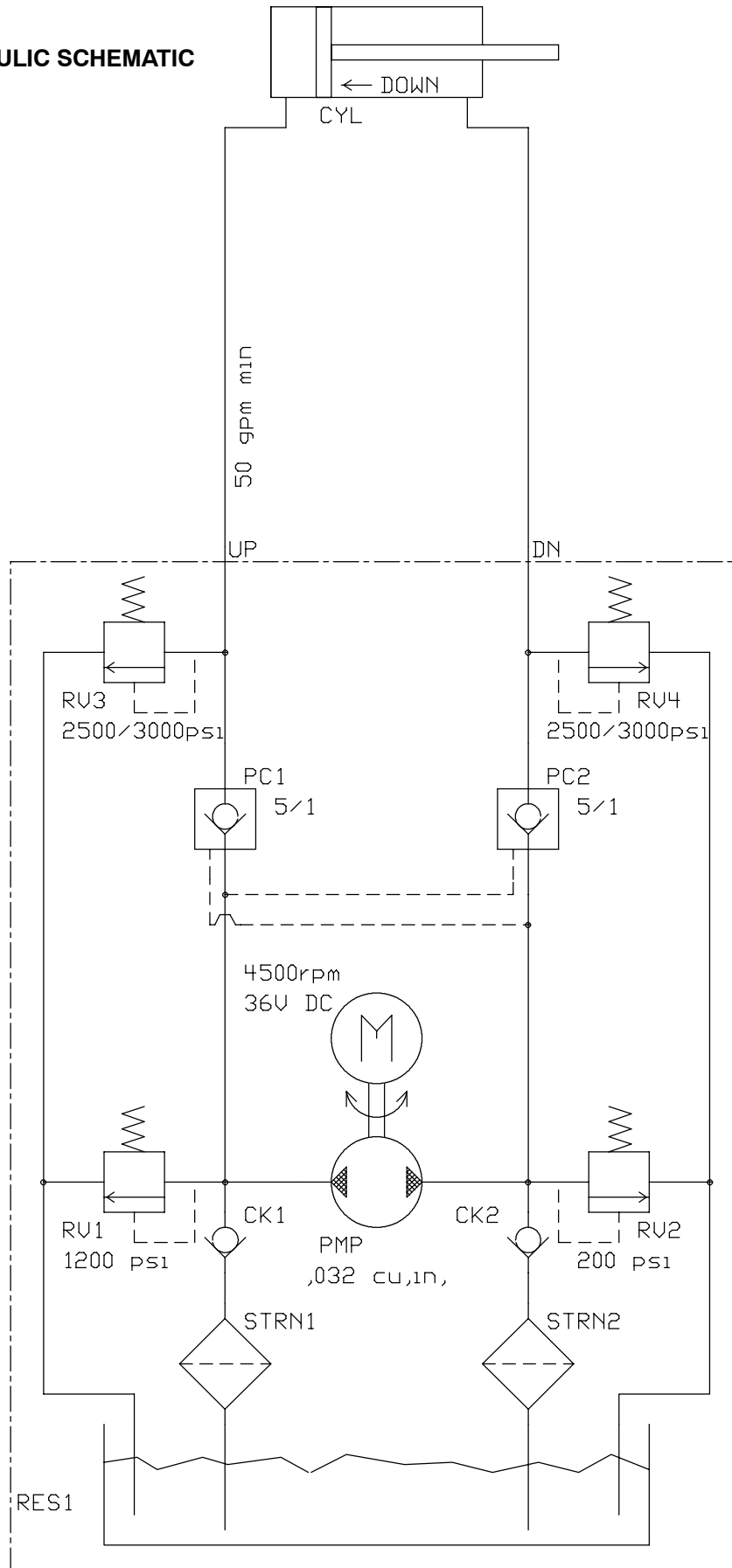

HYDRAULIC HOSE GROUP

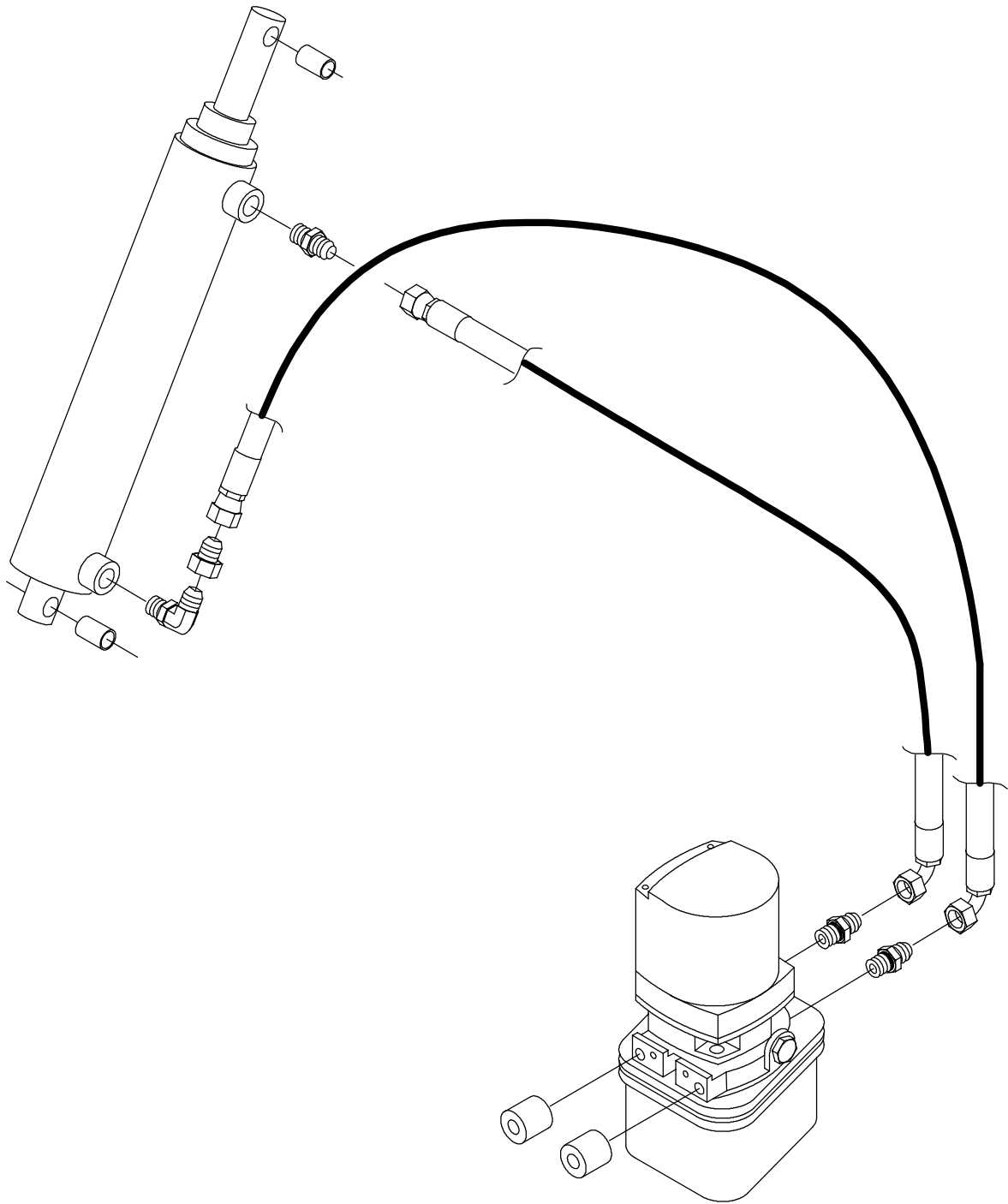



We Need Your Help...

As part of Tennant's Zero Defects Program, we want to know about errors you have found or suggestions you may have regarding our machine manuals. If you find an error or have a suggestion, please complete this postage-paid form and mail it to us. Thank you for helping us make zero defects a way of life at Tennant.

Manual No. _____ Rev. No. _____ Publish Date _____ Page _____
Machine _____ Report Error Suggestion

Name _____ Date _____
Customer Number _____
Company _____
Address _____
City/State/Zip Code _____



TENNANT COMPANY
 Technical Publications #15
 701 North Lilac Drive
 P.O. Box 1452
 Minneapolis, MN 55440-9947

POSTAGE WILL BE PAID BY ADDRESSEE

BUSINESS REPLY MAIL
 FIRST CLASS MAIL PERMIT NO. 94 MINNEAPOLIS, MN



NO POSTAGE
 NECESSARY
 IF MAILED
 IN THE
 UNITED STATES

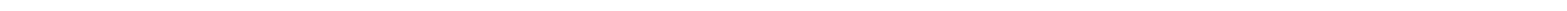
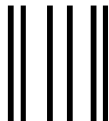

Fold along dotted lines

Tape here

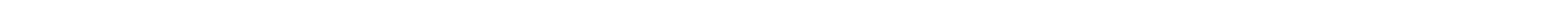



TENNANT COMPANY
 Technical Publications #15
 701 North Lilac Drive
 P.O. Box 1452
 Minneapolis, MN 55440-9947

POSTAGE WILL BE PAID BY ADDRESSEE

BUSINESS REPLY MAIL
 FIRST CLASS MAIL PERMIT NO. 94 MINNEAPOLIS, MN



NO POSTAGE
 NECESSARY
 IF MAILED
 IN THE
 UNITED STATES

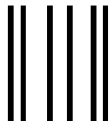

Fold along dotted lines

Tape here

