

ZEUS

Artikel-Nr. Beschreibung

Ersatzteile Einscheibenmaschine Zeus

201027	Schalter elektrisch
201030	Netzkabel, 12 m, Rot
201052	Steckdose Deichsel
201067	Thermoschutzschalter
205101	Steckdosenabdeckung
205106	Zugentlastung
205107	Schalthebel-Set
205108	Verstellhebel, Deichsel
205109	Bedienhebel, Frischwasser
205127	Kabelhaken
206101	Schalter Magentventil
205138	Lagerbock-Set
205139	Zahnradkit, Deichsel

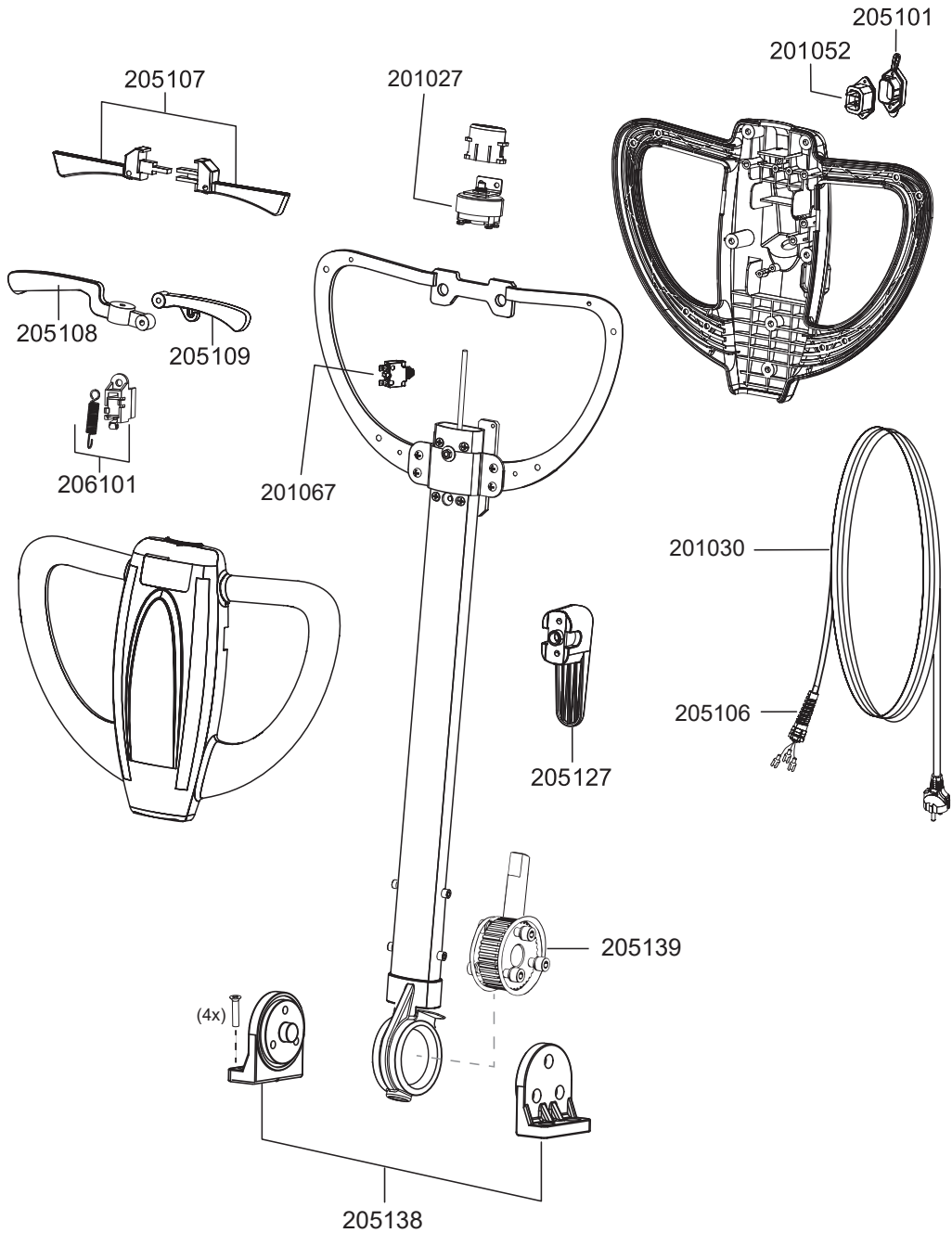

ZEUS

Artikel-Nr. Beschreibung





Ersatzteile Einscheibenmaschine Zeus

203105	Flanschscheibe kplt.
205120	Schrubbürste, 432 mm, (weich)
205121	Schrubbürste, 432 mm, (hart)
205122	Pad-Treibteller, 380 mm
205124	Kondensator, 250 uF (Anlauf)
205125	Kondensator, 30 uF (Betrieb)
206105	Füllschlauch-Set
206106	Motorabdeckung
206107	Klemmleiste
206108	Magnetventil
206110	Frischwasseranschluß kplt.
206111	Gummipuffer
206112	Achse, Rad
206113	Wassertank 10 l
206114	Rad, kplt. Gummiert
206115	Tankventil

Zubehör Einscheibenmaschine Zeus

201005	Pad weiß	17" (VE = 5 Stk.)
201006	Pad rot	17" (VE = 5 Stk.)
201007	Pad schwarz	17" (VE = 5 Stk.)
201008	Pad grün	17" (VE = 5 Stk.)
201009	Queen Bonnet Pad	17"
205131	Bürstenset (205120, 205121, 205122)	
201076	Power Pad	17"
201077	Duo Pad	17"

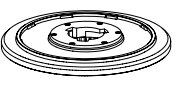
Standardzubehör / Standard Accessories

			
Schrubb-Bürste weich Scrubber Brush soft 205120	Schrubb-Bürste hart Scrubber Brush hard 205121	Padtreibteller Pad disc 205122	Flansch / flange 203105

