

XT 2000

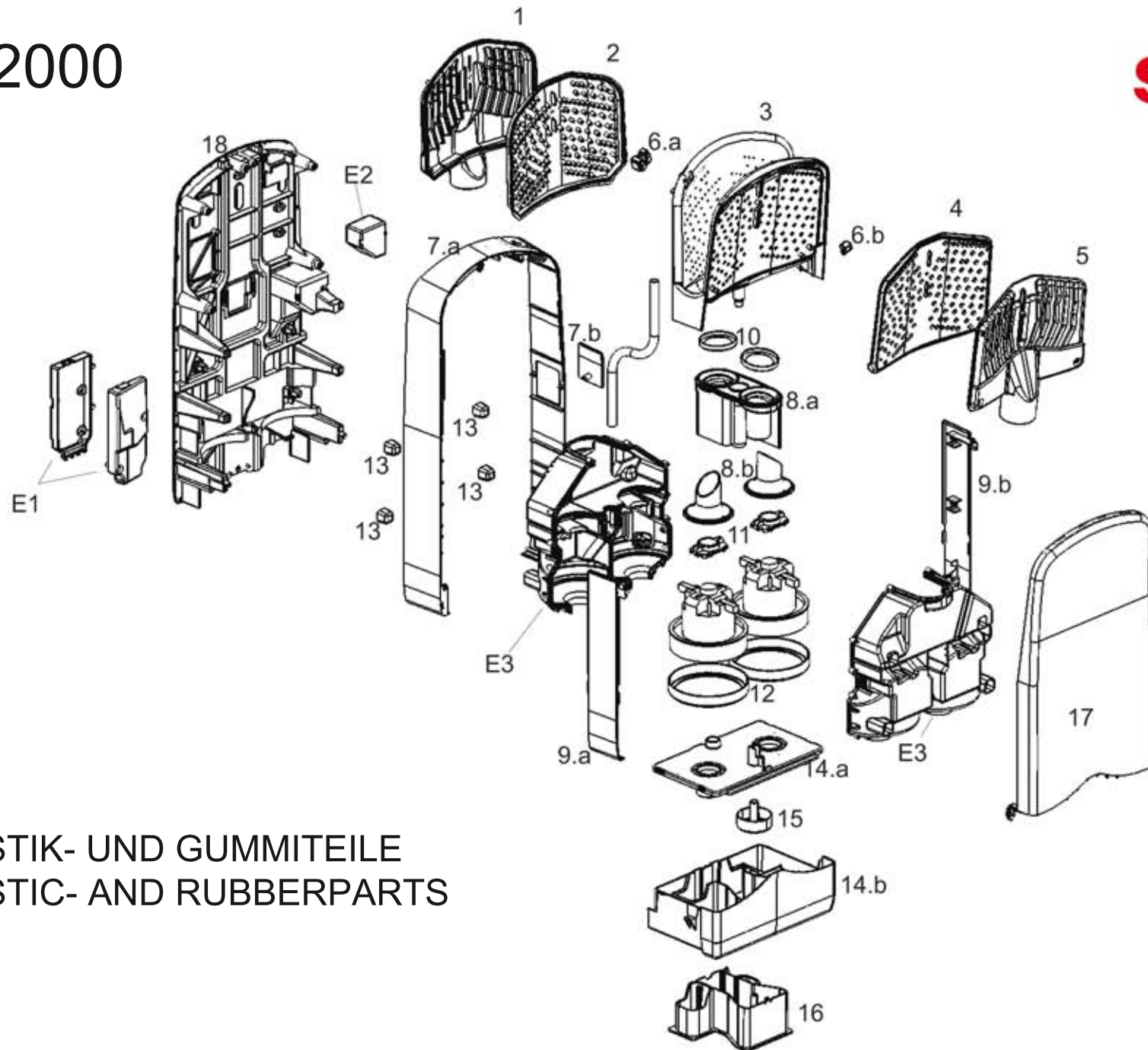

PLASTIK- UND GUMMITEILE
PLASTIC- AND RUBBERPARTS



XT 2000 Ersatzteilliste

XT 2000 Sparepart list

N°	PART
1	Chanel plate
2	Duct plate
3	Drying chamber
4	Duct plate
5	Chanel plate
6-a / 6-b	Big/small window and cover
7-a / 7-b	Side cover and side embelliser
8-a / 8-b	Inlet/outlet air duct
9-a / 9-b	Left/right
10	Air chamber Rubber
11	High Motor rubber
12	Low motor rubber
13	Rubber pad
14-a / 14-b	Base and co
15	Water level sensor
16	Water reservoir
17	Front cover
18	Back panel
E1	PCB box and cover
E2	Conexion box
E3	Motor housing