

PART NO.
OCB451500

© C COPYRIGHT DIMENSIONS IN MILLIMETRES DO NOT SCALE 3RD ANGLE PROJECTION

A2

ITEM	PART No.	PART DESCRIPTION	QTY
1	00-0800-0551	M8 FORM "C" WASHER	6
2	00-0800-0721	M8 NYLOC NUT	3
3	00-0855-0121	M8 x 55 HEX HEAD BOLT Z/P	3
4	02-3853-0000	PAD CENTRE LOCK	1
5	03-6148-0000	ORBIS HANDLE LABEL - TRUVOX	1
6	03-8144-0000	BATT BURN BATTERY COVER	1
7	04-3665-0000	FUSE HOLDER	1
8	04-3761-0000	FUSE 30 A	1
9	04-3948-0500	12V 44AH BATTERY - PEGASUS	2
10	04-3978-0000	CHARGER CORD - EURO	1
11	04-3979-0000	CHARGER CORD - US	1
12	04-3980-0000	CHARGER CORD - AUS	1
13	04-3981-0000	CHARGER CORD - UK	1
14	05-4085-0500	UHS FLEXI-DRIVE 17"	1
15	05-4562-0000	BATTERY BURNISHER DRIVE ASSEMBLY	1
16	05-4564-0000	BATTERY BURNISHER BRUSH GUARD ASSEMBLY	1
17	05-4565-0000	BATTERY BURNISHER HANDLE ASSEMBLY	1
18	05-4566-0000	BATTERY BURNISHER BASE ASSEMBLY	1
19	05-4567-0000	BATTERY BURNISHER MOTOR COVER ASSEMBLY	1
20	05-4696-0000	OCB CHARGER ASSEMBLY - UK	1

PARTS NOT SHOWN

ITEM	PART No.	PART DESCRIPTION	QTY
	02-4558-0000	BATTERY BURNISHER KEYS	2
	05-4579-0000	OCB CHARGER ASSEMBLY - USA (C/W CORD)	
	05-4730-0000	OCB CHARGER ASSEMBLY - AUS (C/W CORD)	
	05-4731-0000	OCB CHARGER ASSEMBLY - EURO (C/W CORD)	

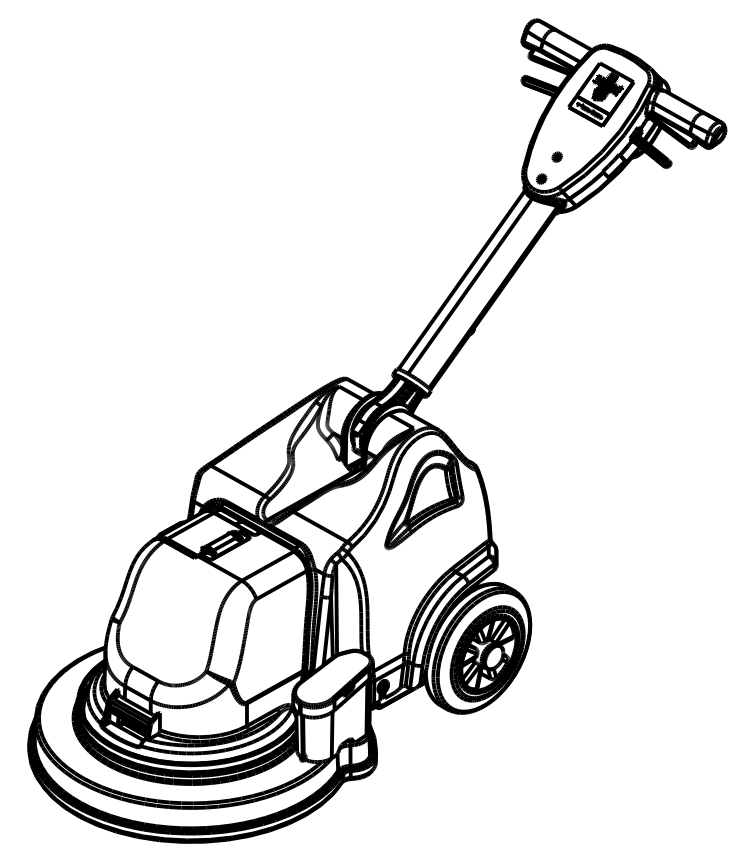
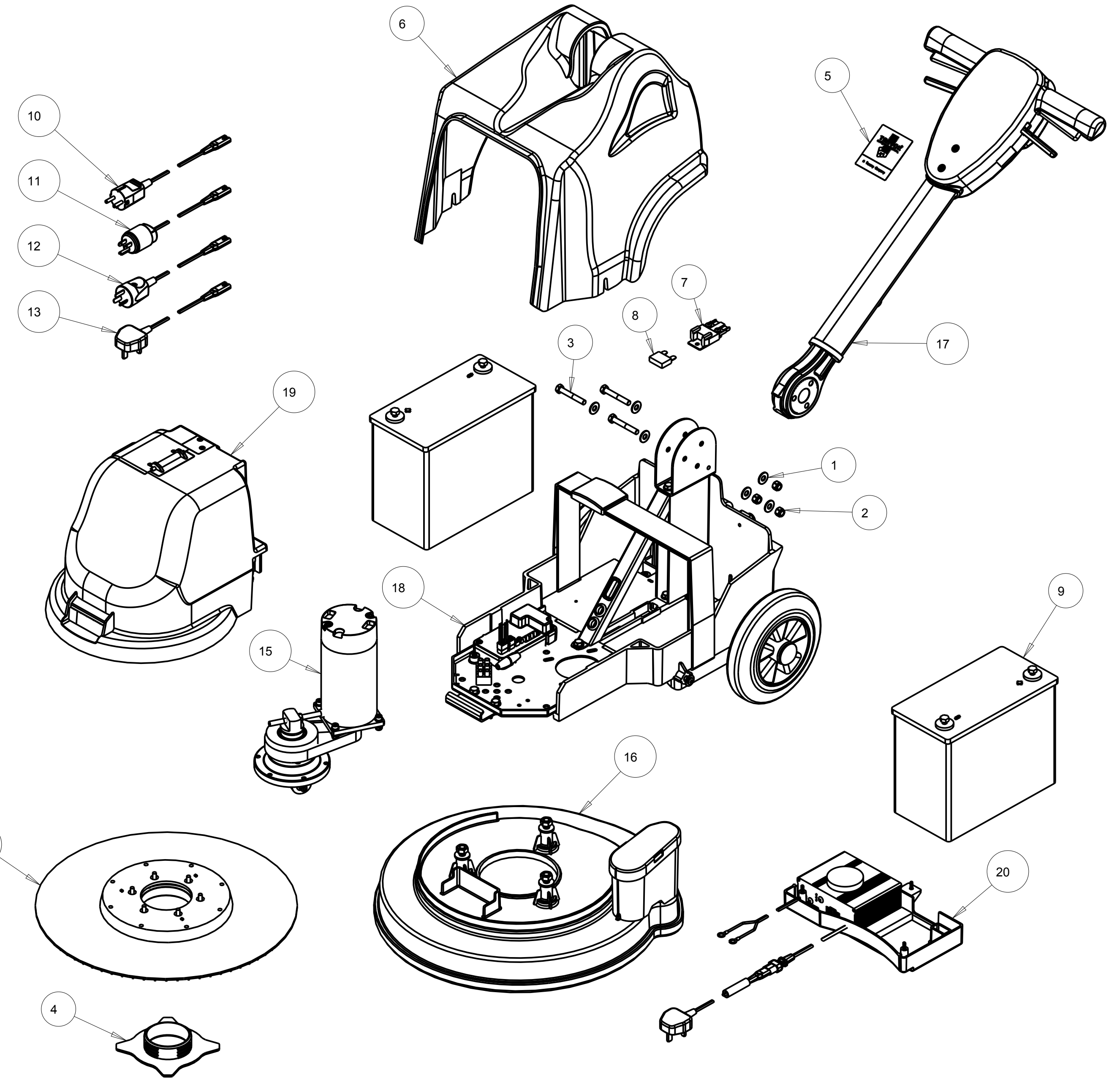

NOTE: CHANGES TO UPDATE ASSEMBLY TO POWER FIRST CHARGER (ISSUE 05 RELEASE) EFFECTIVE FROM SERIAL NUMBER 02500. MACHINE ASSEMBLIES NOW AT SERIES C.

5	1120	CHANGES FOR POWER FIRST CHARGER	NMN	01 SEP 16	MATERIAL:	GEN TOL	TRUVOX™ TRUVOX INTERNATIONAL LIMITED	TITLE:	PART NO.	
4	1118	ADDED PAD CENTRE LOCK	NPD	21 JAN 15		X ± 0.5				
3	1094	UPDATED FLEXI-DRIVE	NPD	28 APR 14	X.X ± 0.2					
2	995	SNAP HOOK ADDED	NMN	11 OCT 10	X.XX ± 0.1					
1	N/A	PRODUCTION RELEASE	NMN	01 MAY 08	ANG ± 0.5°					
ISSUE	ECN	CHANGES	INT	DATE	FINISH:	SCALE: X:X	DRN	CKD	ORBIS CORDLESS BURNISHER	OCB451500
							NMN			

PART NO.
05-4562-0000

© COPYRIGHT

DIMENSIONS IN MILLIMETRES

DO NOT SCALE DRAWING

3RD ANGLE PROJECTION

A3

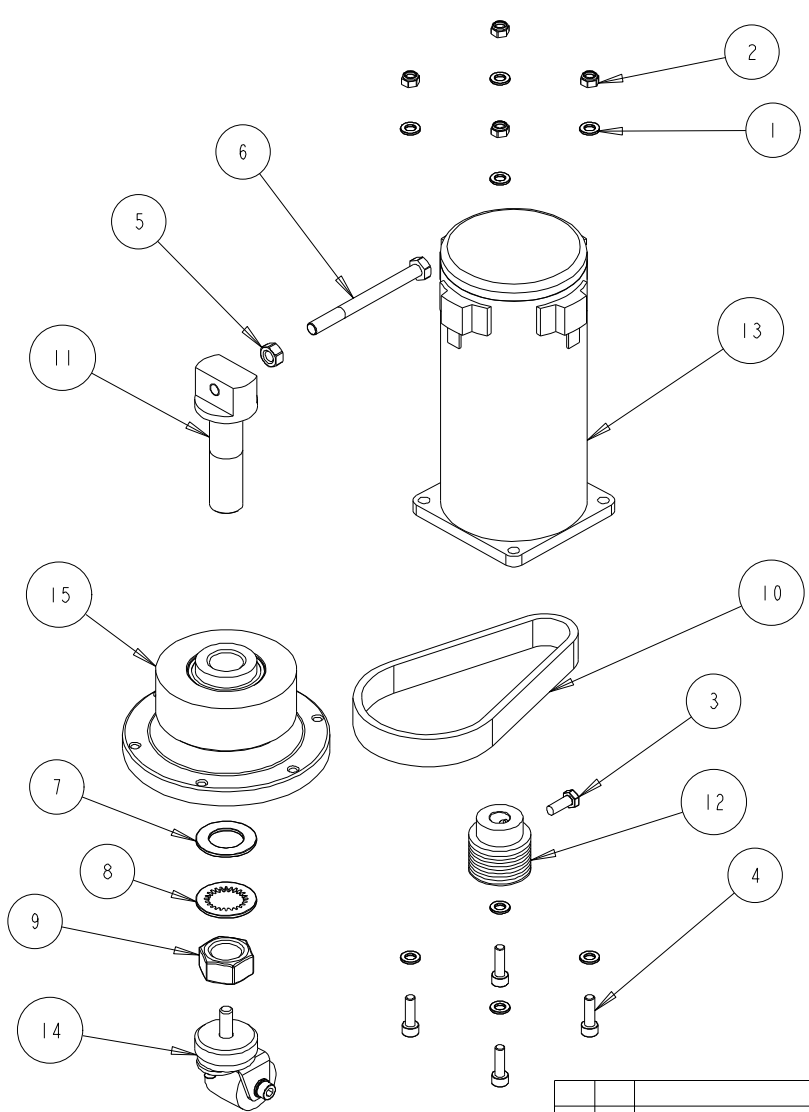

ITEM	PART No.	PART DESCRIPTION	QTY
1	00-0600-0501	M6 FORM "A" PLAIN WASHER	8
2	00-0600-0751	M6 1/2 NYLOC NUT Z/P	4
3	00-0616-0111	M6x 16 HEX HEAD BOLT	1
4	00-0620-0096	M6 X 20 SOCKET HEAD SCREW Z/P	4
5	00-0800-0701	M8 FULL NUT Z/P	1
6	00-0890-0121	M8 x 90 HEX HEAD BOLT Z/P	1
7	00-2000-0501	M20 PLAIN WASHER FORM B Z/P	1
8	00-2000-0521	M20 INTERNAL SHAKEPROOF WASHER	1
9	00-2000-0701	M20 FULL NUT Z/P	1
10	02-4531-0000	VEE BELT	1
11	03-6719-0000	CENTRE SPINDLE	1
12	03-7962-0000	MOTOR PULLEY (BATT BURNISHER)	1
13	04-3930-0500	MOTOR 24V 350 WATT	1
14	05-4560-0000	BATTERY BURNISHER CASTOR ASSEMBLY	1
15	05-4561-0000	BATTERY BURNISHER FLOATING ADAPTOR	1

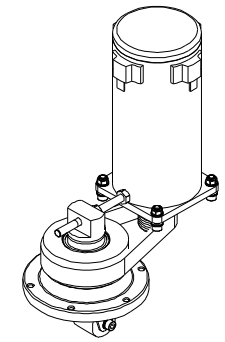

ISSUE	ECN	CHANGES	INT	DATE
3	N/A	UPDATE OF MOTOR P/N	NPD	31 AUG 16
2	N/A	UPDATE OF MOTOR P/N	NPD	17 SEP 14
1	N/A	PRODUCTION RELEASE	NMN	08 APR 09
A	N/A	NEW ASSEMBLY	NMN	25 JUN 08

MATERIAL:	GEN TOL X ±0.5 X.X ±0.2 X.XX ±0.1 ANG ±0.5°
FINISH:	SCALE: X : X
	DRN CKD NMN

TRUVOX™ INTERNATIONAL LIMITED

BATTERY BURNISHER
DRIVE ASSEMBLY

PART NO.
05-4562-0000

PART NO.

05-4560-0000

© COPYRIGHT

DIMENSIONS IN MILLIMETRES

DO NOT SCALE DRAWING

3RD ANGLE PROJECTION

A3

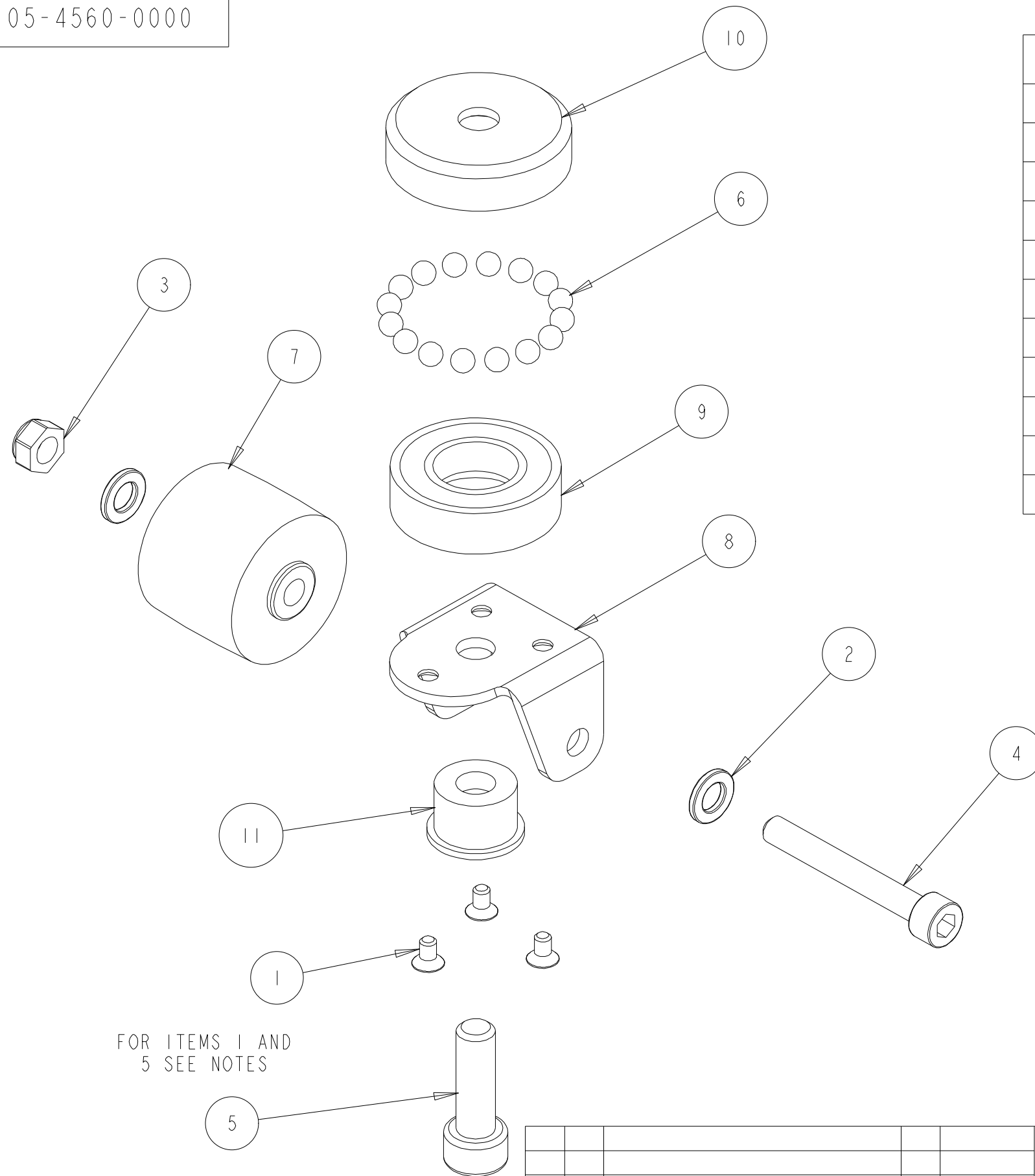

ITEM	PART No.	PART DESCRIPTION	QTY
1	00-0406-0031	M4 X 6 CSK SCREW POZI Z/P	3
2	00-0600-0503	M6 WASHER ST STL	2
3	00-0600-0751	M6 1/2 NYLOC NUT Z/P	1
4	00-0645-0093	M6 X 45 SOCKET HEAD SCREW Z/P	1
5	00-0825-0091	M8 X 25 CAP HEAD SCREW Z/P	1
6	02-4607-0000	4.76 (3/16") DIA BALL	16
7	02-4608-0000	35mm DIA CASTOR	1
8	03-8153-0000	BATT BURN CASTOR CARRIER	1
9	03-8154-0000	BATT BURN CASTOR RACE - LOWER	1
10	03-8155-0000	BATT BURN CASTOR RACE - UPPER	1
11	03-8156-0000	BATT BURN CASTOR BEARING SPIGOT	1

FOR ITEMS 1 AND 5 SEE NOTES

- NOTES:
1. APPLY "THREADLOCK" TO ITEMS 1 (3 OFF) AND ITEM 5 BEFORE FITTING
 2. ITEM 5 TO BE TIGHTENED TO A TORQUE OF 20NM

					MATERIAL:	GEN TOL X ±0.5 X.X ±0.2 X.XX ±0.1 ANG ±0.5°		TRUVOX™ INTERNATIONAL LIMITED	
2	877	NOTES ADDED	NMN	27 AUG 09	FINISH:	SCALE: X : X			
1	N/A	PRODUCTION RELEASE	NMN	08 APR 09		DRN	CKD	BATTERY BURNISHER CASTOR ASSEMBLY	PART NO.
A	N/A	NEW ASSEMBLY	NMN	30 APR 08	ISSUE	ECN	CHANGES	INT	DATE
									05-4560-0000

PART NO.
05-4561-0000

© COPYRIGHT

DIMENSIONS IN MILLIMETRES

DO NOT SCALE DRAWING

3RD ANGLE PROJECTION

A3

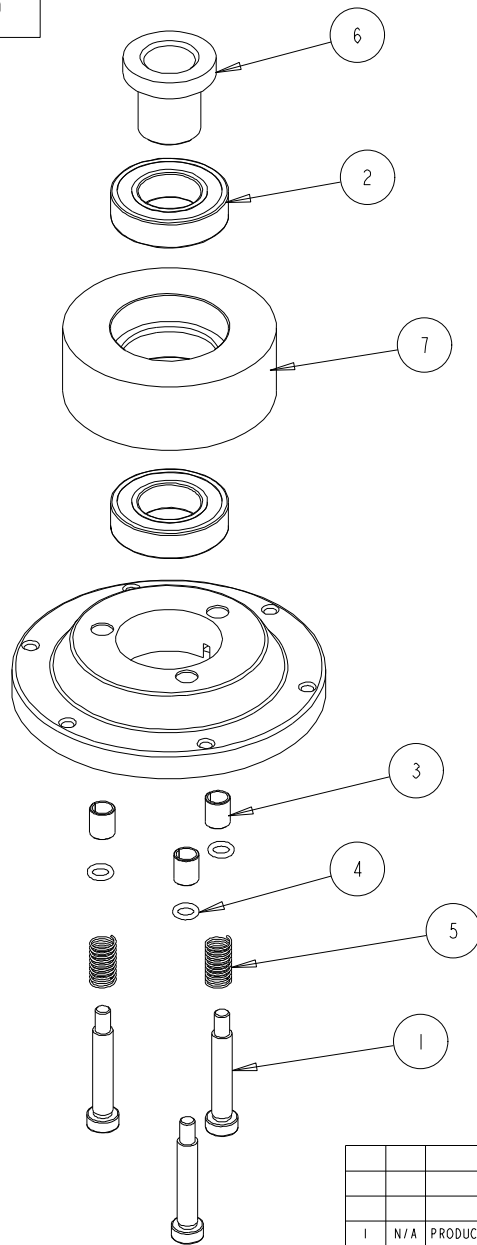

ITEM	PART No.	PART DESCRIPTION	QTY
1	02-3523-0000	M6 X 8 X 40 SHOULDER BOLT	3
2	02-3846-0000	BEARING 6005-2RS	2
3	02-4494-0000	PLAIN BEARING PAP 0812 P10	3
4	02-4496-0000	O-RING 7.5 X 2mm	3
5	02-4541-0000	COMPRESSION SPRING	2
6	03-6718-0000	BEARING SUPPORT SPIGOT	1
7	03-7987-0000	DRIVE PULLEY (BATT BURNISHER)	1

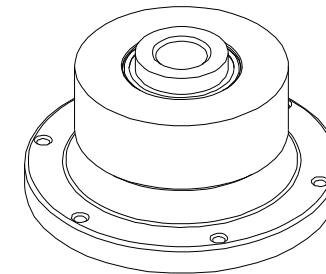

				MATERIAL:		GEN TOL X ±0.5 X.X ±0.2 X.XX ±0.1 ANG ±0.5°		TRUVOX™ INTERNATIONAL LIMITED	
				FINISH:		SCALE: X : X			
I	N/A	PRODUCTION RELEASE	NMN	08 APR 09			DRN CKD		TITLE: BATTERY BURNISHER FLOATING ADAPTOR
A	N/A	NEW ASSEMBLY	NMN	30 APR 08			NMN		
ISSUE	ECN	CHANGES	INT	DATE					PART NO. 05-4561-0000

PART NO.

05-4564-0000

© COPYRIGHT

DIMENSIONS IN MILLIMETRES

DO NOT SCALE DRAWING

3RD ANGLE PROJECTION

A3

ITEM	PART No.	PART DESCRIPTION	QTY
1	00-1000-0513	M10 SPRING WASHER ST/ST	3
2	00-1000-0701	M10 FULL NUT Z/P	3
3	00-1200-0503	M12 WASHER FORM B ST/STL	3
4	02-3653-0000	10mm E-TYPE CIRCLIP	3
5	03-8137-0000	BATT BURN BRUSH GUARD	1
6	03-8138-0000	BATT BURN BRUSH GUARD PILLAR	3
7	03-8151-0000	BATT BURN DUST COLLECTOR	1
8	03-8152-0000	BATT BURN DUST COLLECTOR LID	1
9	03-8158-0000	DUST COLLECTOR GASKET	1
10	03-8194-0000	BATTERY BURNISHER FELT STRIP	1

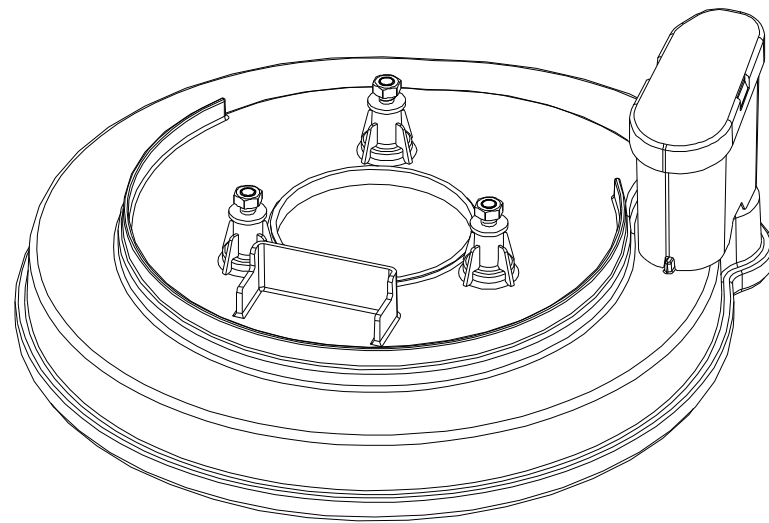
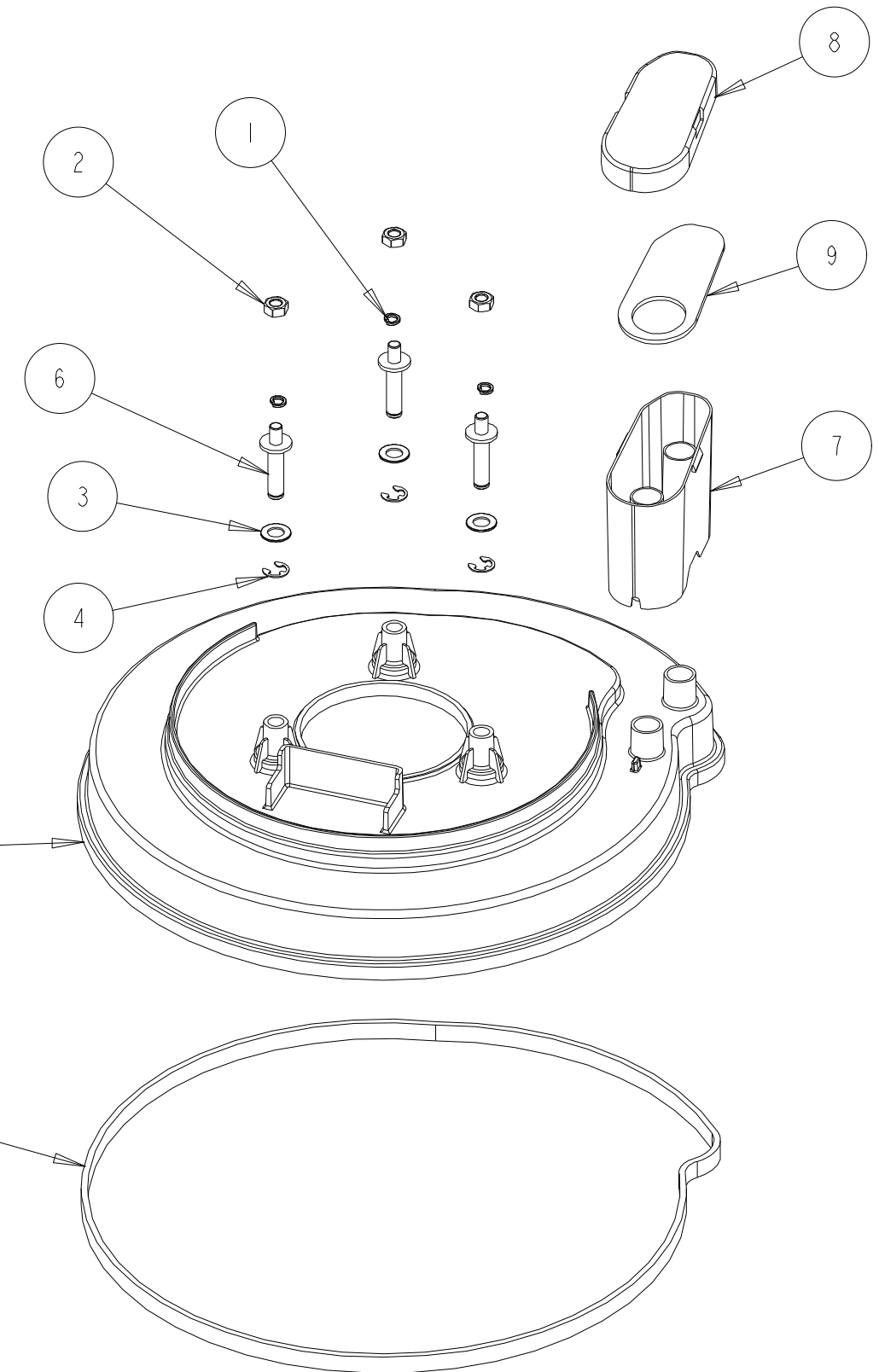

					MATERIAL :	GEN TOL		TRUVOX™ INTERNATIONAL LIMITED	
						X	±0.5		
						X.X	±0.2	TITLE: BATTERY BURNISHER BRUSH GUARD ASSEMBLY	
						X.XX	±0.1		
						ANG	±0.5°		
					FINISH:	SCALE: X : X			
						DRN	CKD		
						NMN			
2	878	CIRCLIPS CHANGED	NMN	26 MAY 09					
1	N/A	PRODUCTION RELEASE	NMN	08 APR 09					
A	N/A	NEW ASSEMBLY	NMN	30 APR 08					
ISSUE	ECN	CHANGES	INT	DATE					

PART NO.
05-4565-0000

© COPYRIGHT DIMENSIONS IN MILLIMETRES DO NOT SCALE 3RD ANGLE PROJECTION

A2

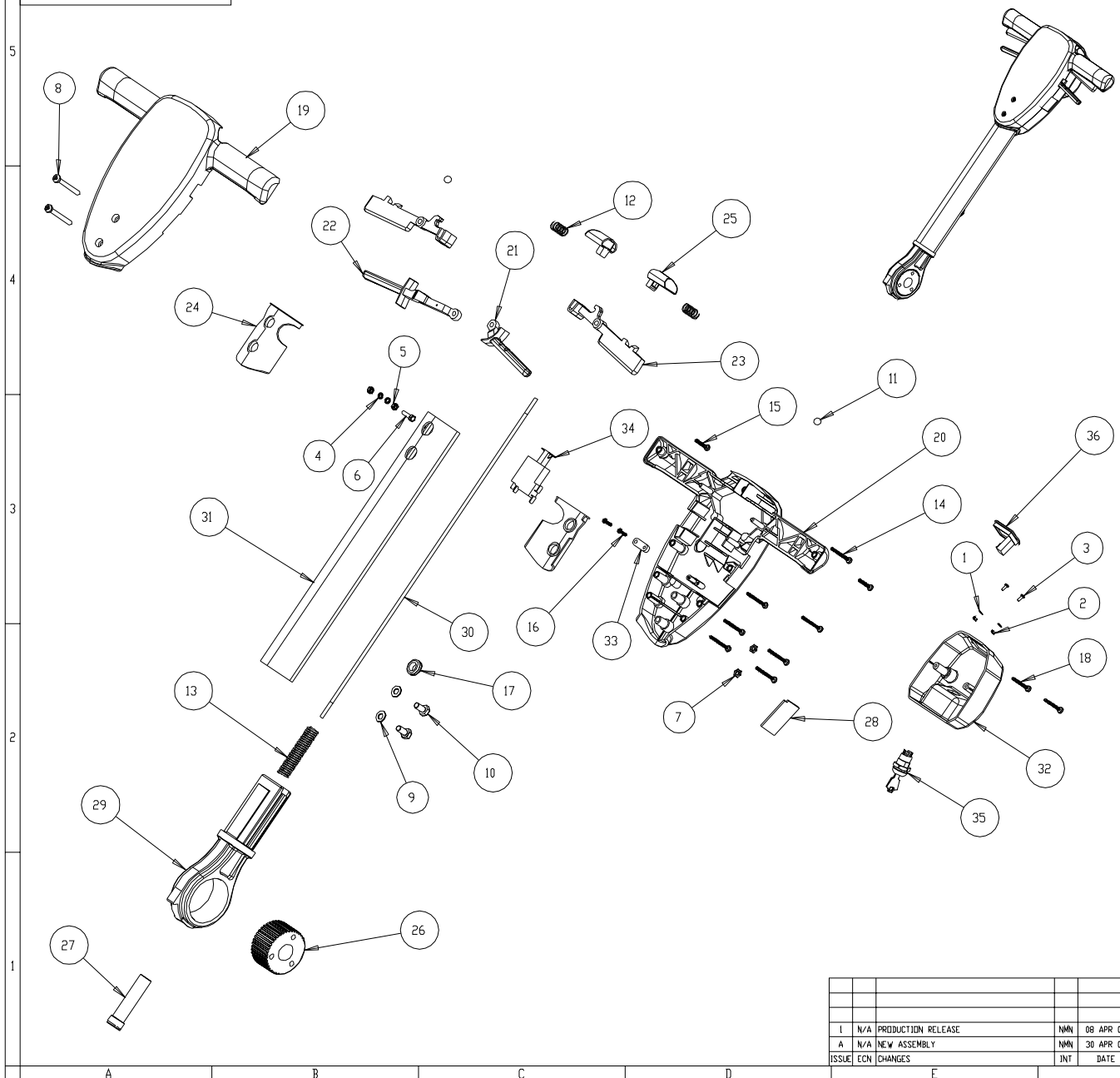

ITEM	PART No.	PART DESCRIPTION	QTY
1	00-0300-0501	M3 FORM A WASHER	2
2	00-0300-0701	M3 FULL NUT Z/P	2
3	00-0308-0011	M3 x 8 POZI PAN SCREW Z/P	2
4	00-0500-0511	M5 SINGLE COIL SPRING WASHER	2
5	00-0500-0701	M5 FULL NUT Z/P	2
6	00-0520-0111	M5 X 20 HEX HEAD SCREW	1
7	00-0600-0771	M6 HALF NUT Z/P	2
8	00-0650-0011	M6 X 50 POZI PAN HEAD SCREW Z/P	2
9	00-0800-0501	M8 WASHER ZINC PLATED	2
10	00-0816-0111	M8 X 16 HEX SET SCREW HTG 8.8 Z1/P	2
11	02-3186-0000	8mm BALL BEARING	2
12	02-3510-0000	HANDLE INTERLOCK SPRING	2
13	02-3511-0000	GEAR DOG SPRING	1
14	02-3516-0000	KB50 X 40 SELF TAP SCREW	7
15	02-3517-0000	KB50 X 25 SELF TAP SCREW	2
16	02-3518-0000	KB40 X 14 SELF TAP SCREW	2
17	02-3520-0000	DIAPHRAGM GROMMET	1
18	02-4613-0000	KB50 X 35 SELF TAP SCREW	2
19	03-6086-0027	CONTROL BOX FRONT	1
20	03-6087-0027	CONTROL BOX REAR	1
21	03-6088-0035	SOLUTION LEVER	1
22	03-6089-0035	GEAR OPERATING LEVER	1
23	03-6090-0035	HANDLE TRIGGER	2
24	03-6091-0000	HANDLE RUBBER BOOT	2
25	03-6092-0035	INTERLOCK BUTTON	2
26	03-6096-0000	HANDLE GEAR	1
27	03-6097-0000	GEAR DOG	1
28	03-6693-0000	ORBIS SOCKET BLANKING PLATE	1
29	03-7831-0000	PRESSURE DIE CAST ALUMINIUM KNUCKLE	1
30	03-7919-0000	GEAR ROD - SOLARIS	1
31	03-7927-0000	OVAL HANDLE TUBE - SOLARIS	1
32	03-8157-0000	BATT BURN HANDLE BDX	1
33	04-0237-0000	CABLE CLAMP	1
34	04-3237-0000	SCHULTE SWITCH	1
35	04-3654-0000	KEYSWITCH	1
36	04-3723-0000	TRUCHARGE MODULE KIT	1

MATERIAL:		GEN: X TOL: ±0.5 XX: ±0.2 XXX: ±0.1 ANG: ±0.5°	TRUVOX™ INTERNATIONAL LIMITED	
I	N/A	PRODUCTION RELEASE	NMN	08 APR 09
A	N/A	NEW ASSEMBLY	NMN	30 APR 08
ISSUE	ECN	CHANGES	INT	DATE
FINISH:		SCALE: X - X	TITLE: BATTERY BURNISHER HANDLE ASSEMBLY - TRUVOX	
		DRN	CKD	PART NO: 05-4565-0000

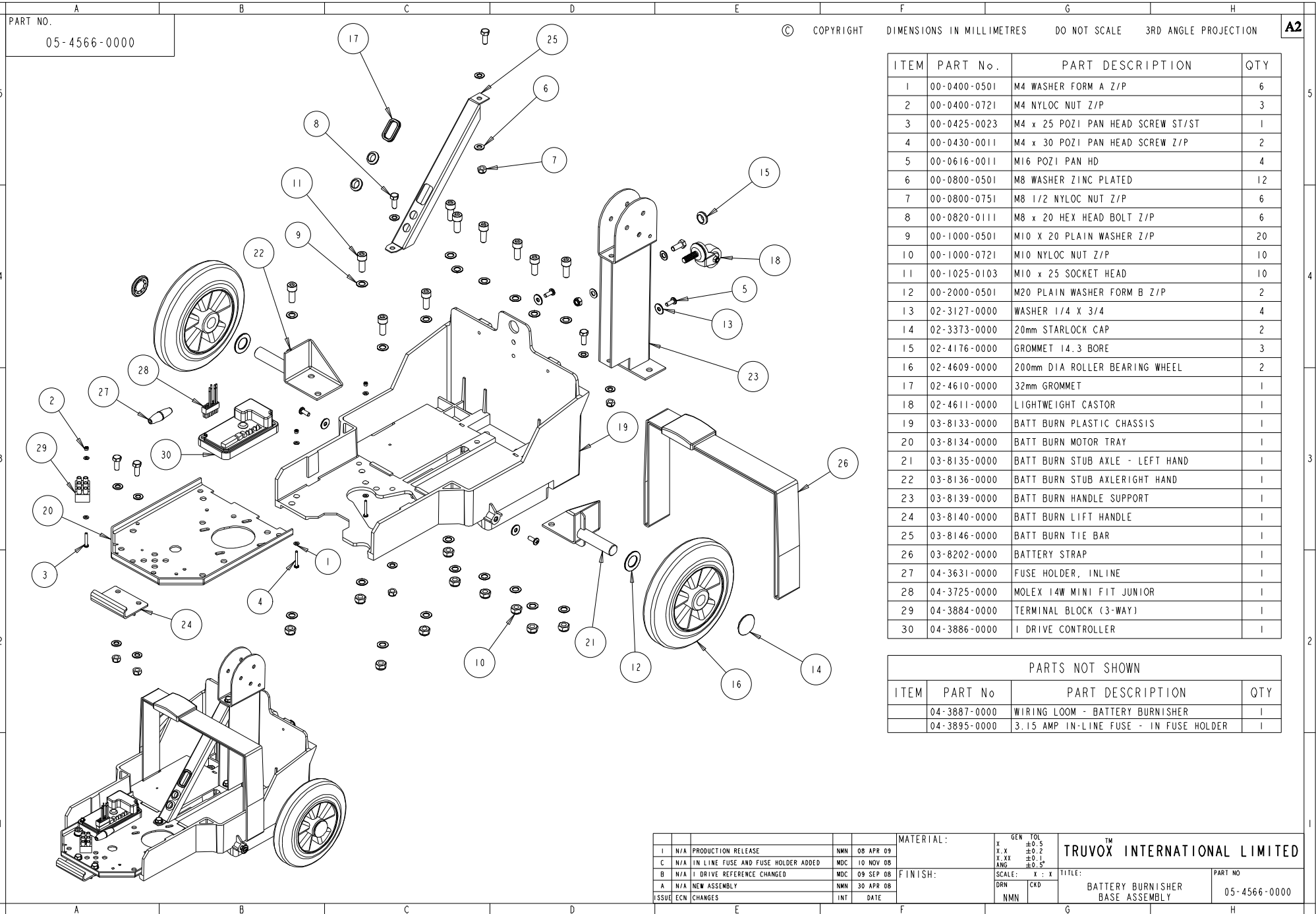

PART NO.
05-4566-0000

© COPYRIGHT DIMENSIONS IN MILLIMETRES DO NOT SCALE 3RD ANGLE PROJECTION **A2**

ITEM	PART No.	PART DESCRIPTION	QTY
1	00-0400-0501	M4 WASHER FORM A Z/P	6
2	00-0400-0721	M4 NYLOC NUT Z/P	3
3	00-0425-0023	M4 x 25 POZI PAN HEAD SCREW ST/ST	1
4	00-0430-0011	M4 x 30 POZI PAN HEAD SCREW Z/P	2
5	00-0616-0011	M16 POZI PAN HD	4
6	00-0800-0501	M8 WASHER ZINC PLATED	12
7	00-0800-0751	M8 1/2 NYLOC NUT Z/P	6
8	00-0820-0111	M8 x 20 HEX HEAD BOLT Z/P	6
9	00-1000-0501	M10 X 20 PLAIN WASHER Z/P	20
10	00-1000-0721	M10 NYLOC NUT Z/P	10
11	00-1025-0103	M10 x 25 SOCKET HEAD	10
12	00-2000-0501	M20 PLAIN WASHER FORM B Z/P	2
13	02-3127-0000	WASHER 1/4 X 3/4	4
14	02-3373-0000	20mm STARLOCK CAP	2
15	02-4176-0000	GROMMET 14.3 BORE	3
16	02-4609-0000	200mm DIA ROLLER BEARING WHEEL	2
17	02-4610-0000	32mm GROMMET	1
18	02-4611-0000	LIGHTWEIGHT CASTOR	1
19	03-8133-0000	BATT BURN PLASTIC CHASSIS	1
20	03-8134-0000	BATT BURN MOTOR TRAY	1
21	03-8135-0000	BATT BURN STUB AXLE - LEFT HAND	1
22	03-8136-0000	BATT BURN STUB AXLERIGHT HAND	1
23	03-8139-0000	BATT BURN HANDLE SUPPORT	1
24	03-8140-0000	BATT BURN LIFT HANDLE	1
25	03-8146-0000	BATT BURN TIE BAR	1
26	03-8202-0000	BATTERY STRAP	1
27	04-3631-0000	FUSE HOLDER, INLINE	1
28	04-3725-0000	MOLEX 14W MINI FIT JUNIOR	1
29	04-3884-0000	TERMINAL BLOCK (3-WAY)	1
30	04-3886-0000	I DRIVE CONTROLLER	1

PARTS NOT SHOWN			
ITEM	PART No.	PART DESCRIPTION	QTY
	04-3887-0000	WIRING LOOM - BATTERY BURNISHER	1
	04-3895-0000	3.15 AMP IN-LINE FUSE - IN FUSE HOLDER	1

I N/A PRODUCTION RELEASE		MMN	08 APR 09	MATERIAL:	GEN TOL	TM	TRUVOX INTERNATIONAL LIMITED
C	N/A IN LINE FUSE AND FUSE HOLDER ADDED	MDC	10 NOV 08		X ±0.5		
B	N/A I DRIVE REFERENCE CHANGED	MDC	09 SEP 08	FINISH:	X ±0.2	SCALE: X : X	TITLE: BATTERY BURNISHER BASE ASSEMBLY
A	N/A NEW ASSEMBLY	MMN	30 APR 08		X ±0.1		
ISSUE CHANGES		INT	DATE	DRN CKD		PART NO. 05-4566-0000	

PART NO.
05-4567-0000

© COPYRIGHT

DIMENSIONS IN MILLIMETRES

DO NOT SCALE DRAWING

3RD ANGLE PROJECTION

A3

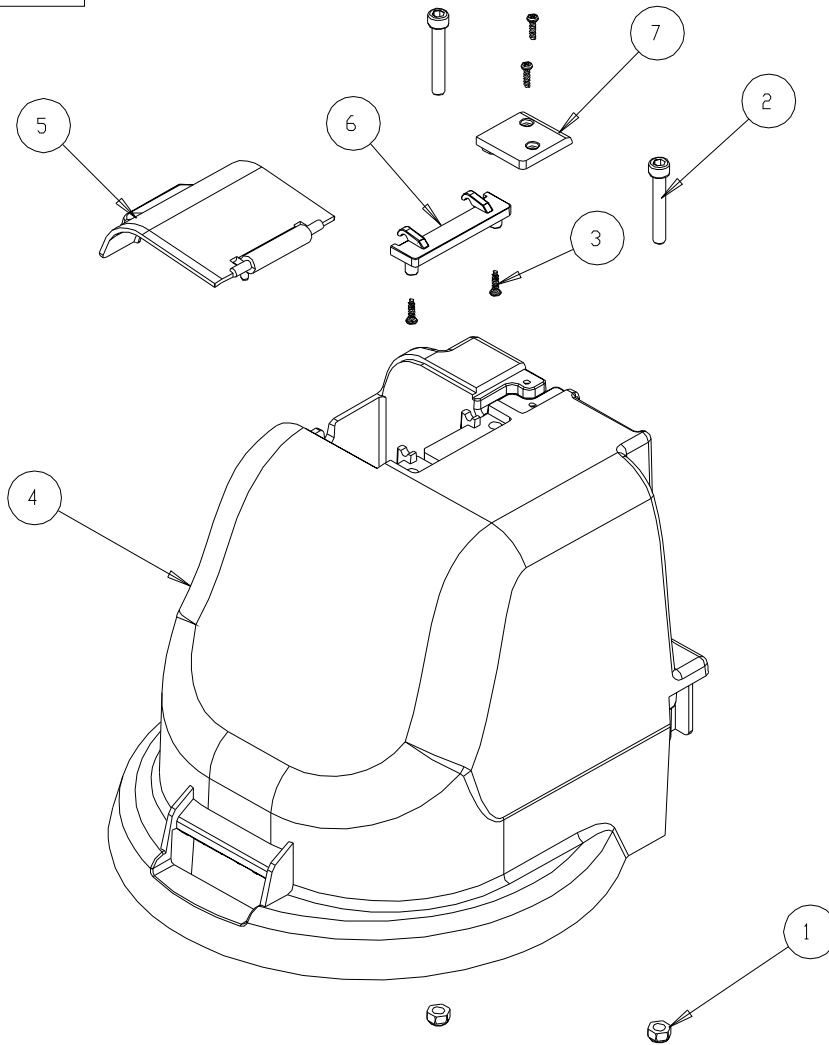

ITEM	PART No.	PART DESCRIPTION	QTY
1	00-0800-0751	M8 1/2 NYLOC NUT Z/P	2
2	00-0850-0091	M8 x 50 SOCKET HEAD SCREW Z/P	2
3	02-3518-0000	KB40 X 14 SELF TAP SCREW	4
4	03-8143-0000	BATT BURN MOTOR COVER	1
5	03-8148-0000	BATT BURN CABLE COVER	1
6	03-8149-0000	BATT BURN HINGE COVER	1
7	03-8150-0000	BATT BURN CABLE CLAMP	1

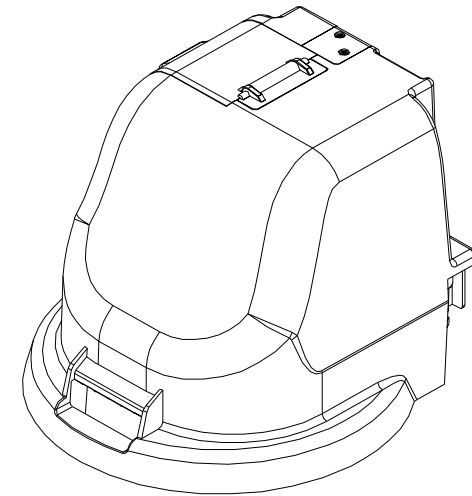

						MATERIAL:	GEN TOL x ±0.5 x.x ±0.2 x.xx ±0.1 ANG ±0.5°	TM TRUVOX INTERNATIONAL LIMITED	
1	N/A	NEW PART	NMN	01 MAY 08		FINISH:	SCALE: x : x	TITLE:	PART NO.
ISSUE	ECN	CHANGES	INT	DATE			DRN CKD NMN	BATTERY BURNISHER MOTOR COVER ASSEMBLY	05-4567-0000

PART NO.

04-3887-0000

© COPYRIGHT DIMENSIONS IN MILLIMETRES
DO NOT SCALE DRAWING 3RD ANGLE PROJECTION

A4

THE OCB WIRING KIT COMPRISES THE FOLLOWING COMPONENTS:

PART NUMBER	DESCRIPTION	QTY
04-3887-0002	POWER LEAD - BLACK	1
04-3887-0003	POWER LEAD - RED	1
04-3887-0004	BATTERY LINK - RED	1
04-3887-0005	BATTERY LINK - BLACK	1
04-3887-0006	I DRIVE LEAD - BLACK	1
04-3887-0007	I DRIVE LEAD - RED	1

FOR DETAILS REFER TO THE COMPONENT DRAWINGS LISTED

NOTE: THE OCB DROP LEAD (04-3887-0001)
IS LISTED SEPARATELY IN THE HANDLE BOM

8	1160	COMPONENTS INDIVIDUALLY LISTED	NMN	21 JUN 16
ISSUE	ECN	CHANGES	INT	DATE

MATERIAL:	GEN TOL X ± 0.5 X.X ± 0.2 X.XX ± 0.1 ANG ± 0.5°	TM TRUVOX INTERNATIONAL LIMITED		
SEE NOTES				
FINISH:	SCALE: X : X	TITLE:	PART NO.	
SEE NOTES	DRN NMN	CKD	OCB WIRING KIT	04-3887-0000

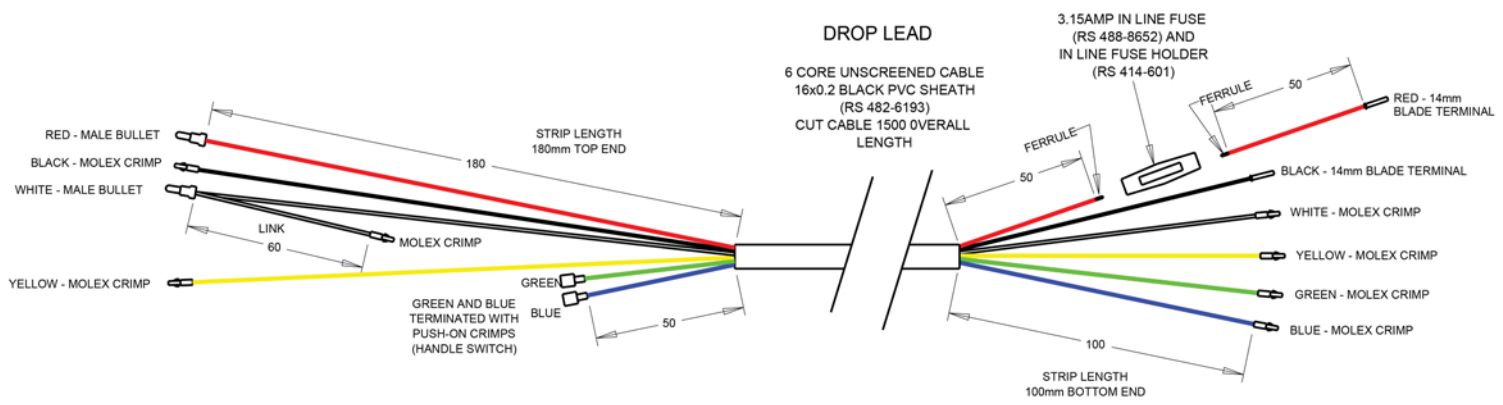

				MATERIAL:		GEN TOL		TM	
				SEE NOTES		X ± 0.5		TRUVOX INTERNATIONAL LIMITED	
						XX ± 0.2			
						XXX ± 0.1			
						ANG ± 0.5°			
1	1160	NEW DRAWING		NMN	21 JUN 16	SCALE: X : X		TITLE:	
ISSUE	ECN	CHANGES		INT	DATE	DRN	CKD	OCB WIRING DROP LEAD	
						NMN		PART NO.	
								04-3887-0001	

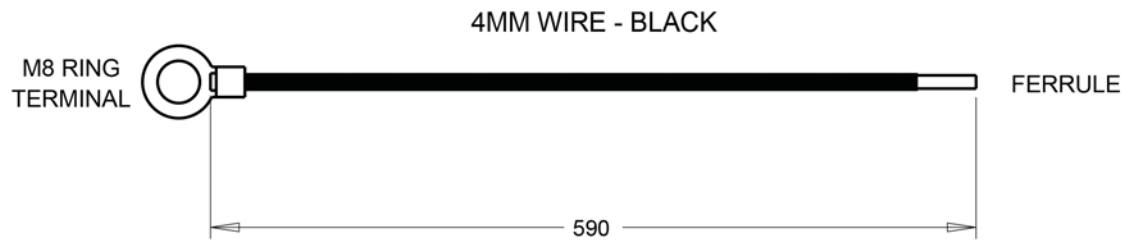

				MATERIAL:		GEN TOL		TM	
				SEE NOTES		X ± 0.5		TRUVOX INTERNATIONAL LIMITED	
						XX ± 0.2			
						XXX ± 0.1			
						ANG ± 0.5°			
1	1160	NEW DRAWING		NMN	21 JUN 16	SCALE: X : X		TITLE:	
ISSUE	ECN	CHANGES		INT	DATE	DRN	CKD	POWER LEAD - BLACK	
						NMN		PART NO.	
								04-3887-0002	

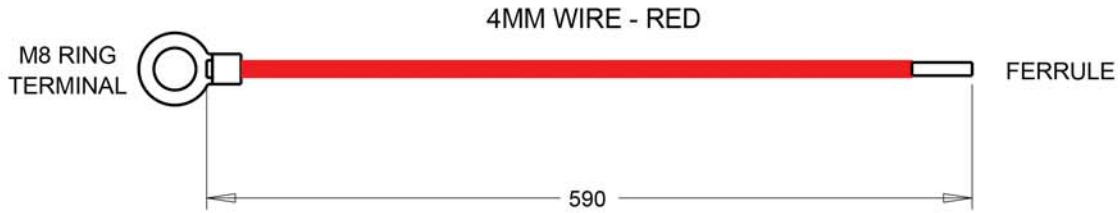

					MATERIAL:	GEN TOL		TRUVOX INTERNATIONAL LIMITED <small>TM</small>		
					SEE NOTES	X ± 0.5				
					FINISH:	SCALE: X : X		TITLE:		PART NO.
					SEE NOTES	DRN	CKD	POWER LEAD - RED		04-3887-0003
1	1160	NEW DRAWING	NMN	21 JUN 16						
ISSUE	ECN	CHANGES	INT	DATE						

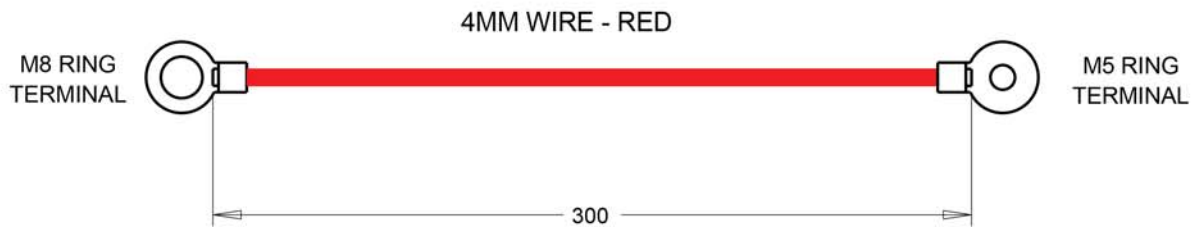

					MATERIAL:	GEN TOL		TRUVOX INTERNATIONAL LIMITED <small>TM</small>		
					SEE NOTES	X ± 0.5				
					FINISH:	SCALE: X : X		TITLE:		PART NO.
					SEE NOTES	DRN	CKD	BATTERY LINK - RED		04-3887-0004
1	1160	NEW DRAWING	NMN	21 JUN 16						
ISSUE	ECN	CHANGES	INT	DATE						

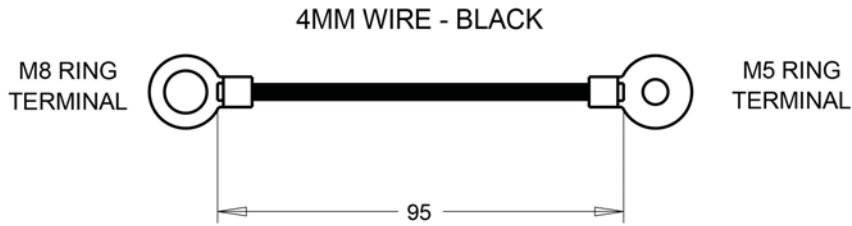

				MATERIAL:		GEN TOL		TM TRUVOX INTERNATIONAL LIMITED	
				SEE NOTES		X ± 0.5 X.X ± 0.2 X.XX ± 0.1 ANG ± 0.5°			
				FINISH:		SCALE: X : X		TITLE:	
				SEE NOTES		DRN CKD		PART NO.	
1	1160	NEW DRAWING		NMN	21 JUN 16			BATTERY LINK - BLACK	
ISSUE	ECN	CHANGES		INT	DATE			04-3887-0005	

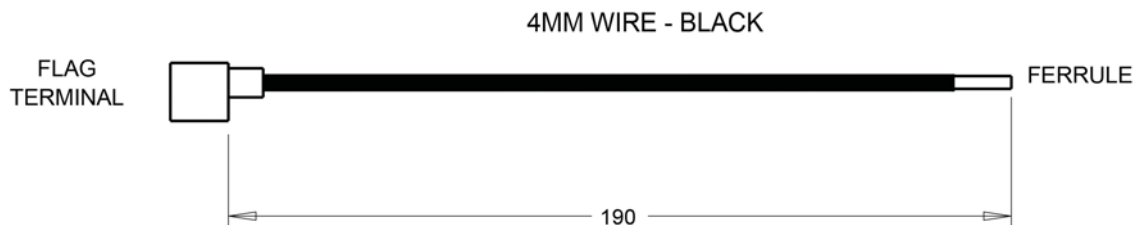

				MATERIAL:		GEN TOL		TM TRUVOX INTERNATIONAL LIMITED	
				SEE NOTES		X ± 0.5 X.X ± 0.2 X.XX ± 0.1 ANG ± 0.5°			
				FINISH:		SCALE: X : X		TITLE:	
				SEE NOTES		DRN CKD		PART NO.	
1	1160	NEW DRAWING		NMN	21 JUN 16			I DRIVE LEAD - BLACK	
ISSUE	ECN	CHANGES		INT	DATE			04-3887-0006	

PART NO.
04-3887-0007

© COPYRIGHT DIMENSIONS IN MILLIMETRES DO NOT SCALE DRAWING 3RD ANGLE PROJECTION

A4

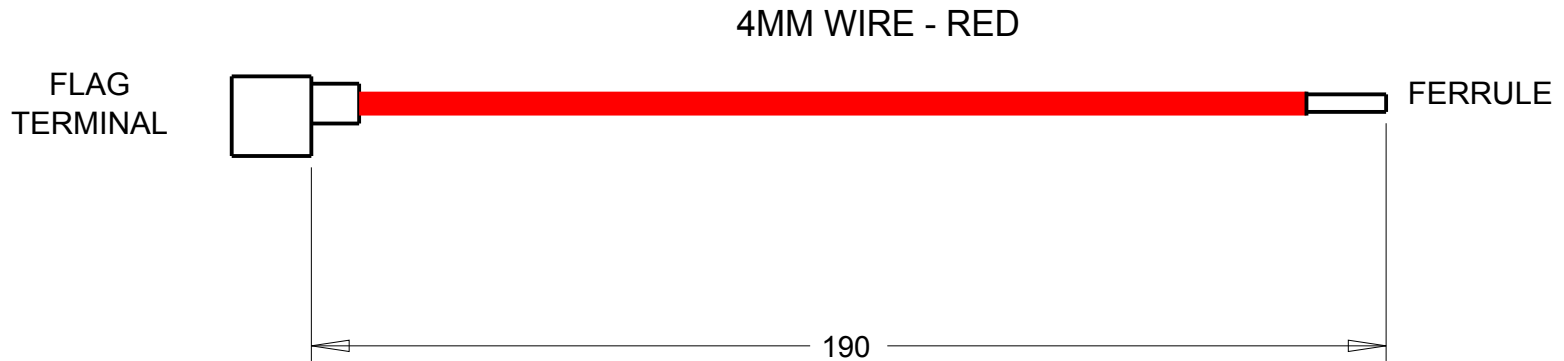

					MATERIAL:	GEN TOL	™	
					SEE NOTES	X ± 0.5	TRUVOX INTERNATIONAL LIMITED	
						X.X ± 0.2		
						X.XX ± 0.1		
						ANG ± 0.5°		
					FINISH:	SCALE: X : X	TITLE:	
					SEE NOTES	DRN	PART NO.	
						CKD		
1	1160	NEW DRAWING	NMN	21 JUN 16		NMN	I DRIVE LEAD - RED	
ISSUE	ECN	CHANGES	INT	DATE			04-3887-0007	