

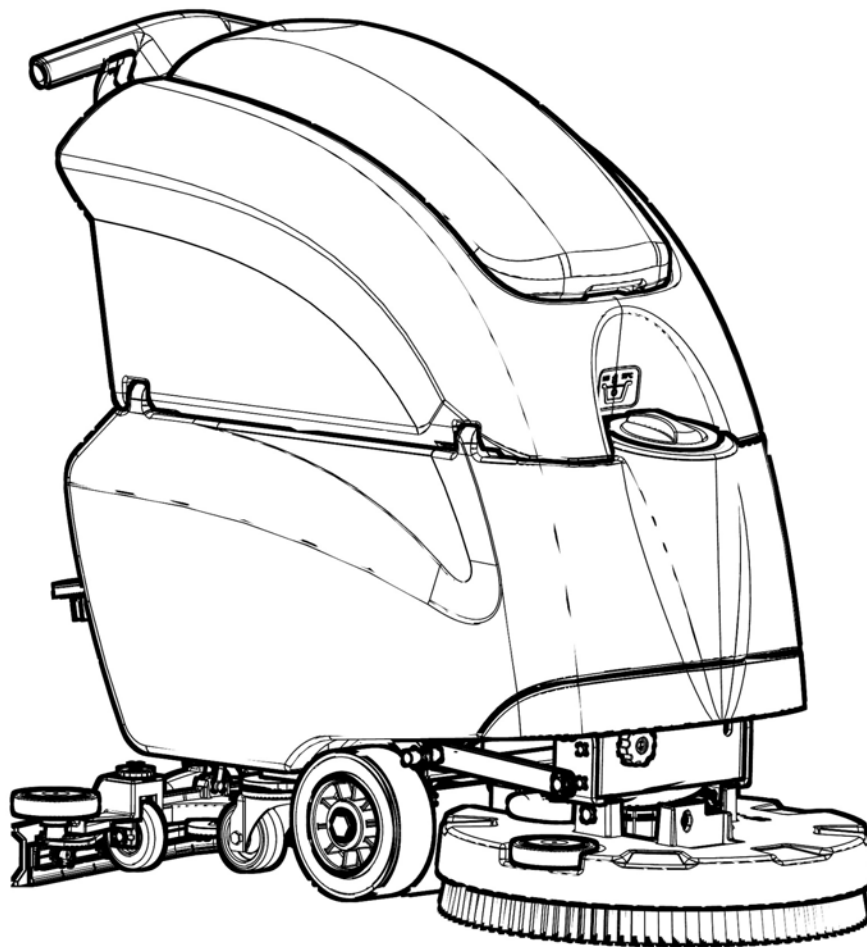

WORKSHOP HANDBOOK

MMx B/BT



Version: **AA**

Date: **November 14, 2014**

Document Number: **10051890**

ATTENTION

This document is valid starting from serial number:

214010589

Contents

I	Product Introduction	5
1	Serial Number and Technical Support	6
1.1	The Serial Tag	6
1.2	Serial Tag location	6
2	Main Technical Features	7
II	Anomalies Resolution Guide	9
3	Trouble-shooting for the most common anomalies.	10
3.1	Electrical system: what to do if.	10
3.2	Mechanical scrubbing system: what to do if.	12
3.3	Drying system: what to do if.	13
3.4	Frame and traction system: what to do if.	15
3.5	Solution delivery system: what to do if.	16
4	Disassembling Procedures	17
4.1	Electrical Installation	18
4.2	Mechanical Friction System	22
4.3	Drying System	26
4.4	Frame and Traction System	31
4.5	Solution Delivery System	32
III	Machine Description	36
5	Electrical System	37
5.1	Structure	37
5.2	Description	37
5.3	Location of Electrical components	38
5.4	Adjustments	42
5.5	Maintenance and Checks	44
5.6	Alarm Tables	45
5.7	Technical Features	46
5.8	Recommended Spare Parts	46

6 Mechanical Rubbing System	47
6.1 Description	47
6.2 Adjustments	48
6.3 Maintenance and checks	49
6.4 Technical Features	52
6.5 Consumable Spare Parts	52
6.6 Recommended Spare parts	53
7 Drying System	54
7.1 Structure	54
7.2 Description	54
7.3 Adjustments	55
7.4 Maintenance and Checks	55
7.5 Technical Features	59
7.6 Consumable Spare Parts	59
7.7 Recommended Spare Parts	59
8 Machine Frame and Traction System	60
8.1 Structure	60
8.2 Description	60
8.3 Adjustments	61
8.4 Maintenance and Checks	61
8.5 Technical Features	63
8.6 Consumable Spare Parts	63
8.7 Recommended Spare Parts	63
9 Cleaning Solution Supply System	64
9.1 Description	64
9.2 Structure	64
9.3 Dosing System Structure	65
9.4 Maintenance and Checks	65
9.5 Technical Features	68
9.6 Recommended Spare Parts	68
IV Accessories and Add-On	69
10 Accessories	70
10.1 Accessories List	70
10.2 On board Charger Kit - 437657	70

Part I

Product Introduction

Chapter 1

Serial Number and Technical Support

1.1 The Serial Tag

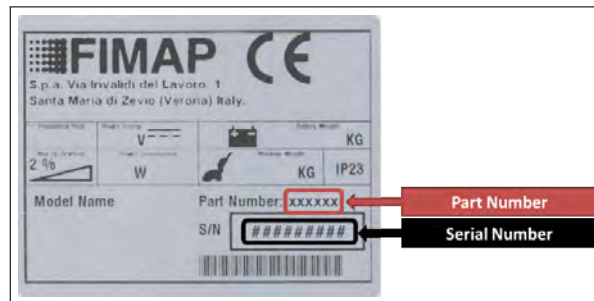

1.2 Serial Tag location

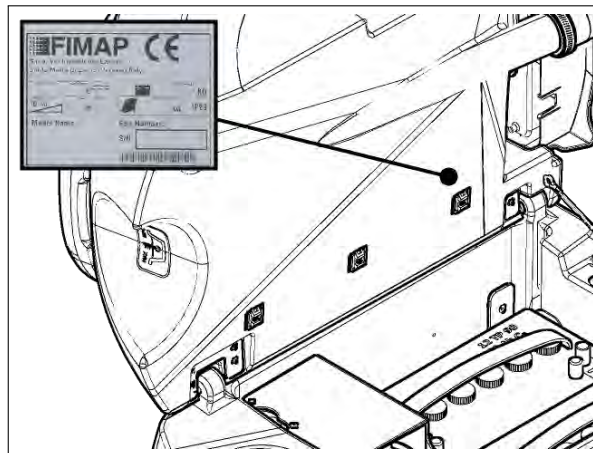

To have access to the Serial Tag is necessary to lift the recovery tank. The Serial Number is an extremely important information which has to be provided each time a Technical Support is required or is necessary to buy spare parts or accessories. The serial number is the only way to identify the machine by model, production date type equipments in general.

Chapter 2

Main Technical Features

Technical Data

TECHNICAL DESCRIPTION	U/M	MMx			
		50B	50BT	52B	52BT
Working width	mm	510	510	490	490
Working capacity, up to	$\frac{m^2}{h}$	1500	1600	1400	1500
Maximum Ramp Gradient	%	2	10	2	10
Steering Diameter	mm	1200	1200	1200	1200
Total power	W	825	975	725	875
Machine Length	mm	1170	1170	1098	1098
Machine Height	mm	1009	1009	1009	1009
Machine Width <i>(without squeegee)</i>	mm	591	591	591	591
Machine Width <i>(with squeegee)</i>	mm	680	680	680	680
Machine Width <i>(with optional squeegee)</i>	mm	780	780	780	780
Sound pressure level <i>(ISO 11201)</i>	LpA dB (A)	≤ 70	≤ 70	≤ 70	≤ 70
Hand vibration level <i>(ISO 5349)</i>	$\frac{m}{s^2}$	≤ 0.75	≤ 0.75	≤ 0.75	≤ 0.75

Weights and Pressures¹

TECHNICAL DESCRIPTION	U/M	MMx			
		50B	50BT	52B	52BT
Machine Weight <i>(empty and without batteries)</i>	kg	80	90	85	95
Machine Gross Weight, work condition <i>(machine + batteries + water)</i>	kg	175	185	180	190

TECHNICAL DESCRIPTION	U/M	MMx
Weight on front right wheel	kg	35.70 ÷ 55.20
Weight on front left wheel	kg	39.40 ÷ 58.60
Weight on rear right wheel	kg	10.00 ÷ 40.50
Weight on rear left wheel	kg	7.50 ÷ 47.20

¹Weight and Pressures depends on how much water there is in the tanks and on what type of battery the machine fits.

Part II

Anomalies Resolution Guide

Chapter 3

Trouble-shooting for the most common anomalies.

3.1 Electrical system: what to do if...

The machine doesn't switch on

- | | | |
|---|---|--|
| 1) The key is in position 0 | ⇒ | <i>Rotate the key in position I.</i> |
| 2) The key switch is not properly connected | ⇒ | <i>Restore the proper connections.</i> |
| 3) The key switch doesn't work | ⇒ | <i>Replace the key switch (see section 4.1.4 at page 18).</i> |
| 4) The batteries don't work properly | ⇒ | <i>Refer to the proper section (see section 3.1 at page 11).</i> |
-

The display shows an alarm message

- | | | |
|---------------------------------------|---|---|
| 1) The display shows an alarm message | ⇒ | <i>Check what alarm message is shown and solve the related issue by following the proper instructions (see section 5.6 at page 45).</i> |
|---------------------------------------|---|---|
-

The machine has a very limited working autonomy

- | | | |
|---|---|---|
| 1) The BDI (Battery Discharge Indicator) is not properly adjusted | ⇒ | <i>Verify the type of battery used on the machine and adjust properly the BDI (see section 5.4.2 at page 42).</i> |
| 2) The batteries have been working for several cycles | ⇒ | <i>Replace the batteries.</i> |
-

The batteries don't work properly

- | | | |
|--|---|--|
| 1) The batteries are not properly connected | ⇒ | <i>Restore the proper battery connections.</i> |
| 2) Battery are discharged | ⇒ | <i>Perform a complete charge cycle.</i> |
| 3) Battery terminal are oxidized | ⇒ | <i>Disconnect the batteries, clean the batteries terminals and reconnect properly the batteries.</i> |
| 4) With the machine in working conditions one battery has a voltage lower (difference higher than 2 V) than the other ones | ⇒ | <i>Replace the battery with lower voltage.</i> |
| 5) The fuse on the loop wire is damaged | ⇒ | <i>Check for possible short circuits, If not present replace the loop wire.</i> |
| 6) The power wires are damaged | ⇒ | <i>Replace the damaged wires.</i> |
| 7) The battery charger is not properly adjusted | ⇒ | <i>Adjust properly the battery charger (see section 5.4.3 at page 43).</i> |
| 8) The battery charger doesn't work | ⇒ | <i>Check the proper section (see section 3.1 at page 11).</i> |
-

The battery charger doesn't work

- | | | |
|--|---|--|
| 1) The battery charger is not connected to the power supply | ⇒ | <i>Connect the charger to a supplied electric socket.</i> |
| 2) The battery charger is not connected to the batteries | ⇒ | <i>Connect the charger to the batteries.</i> |
| 3) The battery charger has one or more lights (or LED) blinking continuously | ⇒ | <i>The battery charger is in error conditions, verify the alarm tables and solve the issue by following the related instructions (see section 5.4.3 at page 43).</i> |
| 4) The battery charger is properly connected but it doesn't switch on | ⇒ | <i>Replace the battery charger (see section 4.1.14 at page 21).</i> |
-

3.2 Mechanical scrubbing system: what to do if...

The machine doesn't clean well		
1)	The machine is switched off	⇒ <i>Switch on the machine.</i>
2)	The machine doesn't switch on	⇒ <i>Refer to the proper section (see section 3.1 at page 10).</i>
3)	The display shows an alarm message	⇒ <i>Check what alarm message is shown and solve the related issue by following the proper instructions (see section 5.6 at page 45).</i>
4)	The machine is in "ECO" mode	⇒ <i>Set the machine in standard mode by pressing again the button "ECO".</i>
5)	The dead man switch doesn't work	⇒ <i>Replace the dead man switch (see section 4.1.5 at page 19).</i>
6)	The brush deck microswitch doesn't work	⇒ <i>Replace the microswitch (see section 4.1.11 at page 20).</i>
7)	The brush deck motor is not supplied	⇒ <i>Verify the motor connections.</i>
8)	The carbon brushes are worn out	⇒ <i>Replace the carbon brushes.</i>
9)	The brush motor is supplied but it doesn't work	⇒ <i>Replace the motor (see section 4.2.6 at page 24)(see section 4.2.7 at page 25).</i>
10)	The brush rotates in opposite way	⇒ <i>Check the motor connections.</i>
11)	The brush deck is lifted from the floor	⇒ <i>Lower the brush deck to let it recline on the floor.</i>
12)	The brush is not properly engaged	⇒ <i>Release and engage properly the brush.</i>
13)	The solution flow rate is not correct or not enough	⇒ <i>Refer to the proper section (see section 3.5 at page 16).</i>

3.3 Drying system: what to do if...

The machine doesn't dry well		
1)	The machine is switched off	⇒ Switch on the machine.
2)	The machine doesn't switch on	⇒ Refer to the proper section (see section 3.1 at page 10).
3)	The recovery tank is full	⇒ Empty the recovery tank following the proper procedure.
4)	The vacuum motor doesn't switch on	⇒ Refer to the proper section (see section 3.3 at page 14).
5)	The machine is in "ECO" mode	⇒ Set the machine in standard mode by pressing again the button "ECO".
6)	The squeegee is lifted up from the floor	⇒ Lower down the squeegee.
7)	The squeegee rubber blades are worn out or broken	⇒ Rotate or replace the squeegee rubber blades (see section 7.4.1 at page 55).
8)	The squeegee is not properly adjusted	⇒ Adjust the squeegee properly following the proper procedure (see section 7.3.1 at page 55).
9)	The squeegee vacuum chamber is stuck or dirty	⇒ Clean the squeegee vacuum chamber.
10)	The squeegee adapter is stuck or dirty	⇒ Clean the squeegee adapter.
11)	The vacuum hose is stuck or broken	⇒ Clean or replace the vacuum hose.
12)	The vacuum hose is not properly fitted in	⇒ Connect the vacuum hose properly.
13)	The intake manifold is stuck or broken	⇒ Clean or replace the intake manifold.
14)	The intake manifold is not properly connected	⇒ Connect the intake manifold properly.
15)	The vacuum filter is dirty or stuck	⇒ Disassemble and clean the vacuum filter (see section 4.3.10 at page 29).
16)	The suction cover is not well positioned	⇒ Position properly the suction cover.
17)	The suction cover gasket doesn't adhere properly	⇒ Replace the suction cover gasket.

The vacuum motor doesn't work properly

- | | | |
|---|---|---|
| 1) The vacuum motor is switched off | ⇒ | <i>Switch on the vacuum motor.</i> |
| 2) The vacuum motor is not powered properly | ⇒ | <i>Check the power connections on the vacuum motor.</i> |
| 3) The display shows an alarm message | ⇒ | <i>Check what alarm message is shown and solve the related issue by following the proper instructions (see section 5.6 at page 45).</i> |
| 4) The squeegee microswitch doesn't work | ⇒ | <i>Replace the microswitch (see section 4.1.12 at page 21).</i> |
| 5) The vacuum motor carbon brushes are worn out | ⇒ | <i>Replace the vacuum motor carbon brushes (see section 7.4.6 at page 58).</i> |
| 6) The vacuum motor is supplied but it doesn't work | ⇒ | <i>Replace the vacuum motor (see section 4.3.11 at page 29).</i> |
-

3.4 Frame and traction system: what to do if...

The machine doesn't go forward

1)	The machine is switched off	⇒	Switch on the machine.
2)	The machine doesn't switch on	⇒	Check the proper section (see section 3.1 at page 10).
3)	The display shows an alarm message	⇒	Check what alarm message is shown and solve the related issue by following the proper instructions (see section 5.6 at page 45).
4)	The dead man lever is not pressed	⇒	Push the dead man lever.
5)	The dead man switch is not properly connected	⇒	Restore the proper connection to the dead man switch.
6)	The dead man switch doesn't work	⇒	Replace the dead man switch.
7)	(BT only) The speed adjuster is at its minimum	⇒	Rotate the speed adjuster to increase the speed.
8)	(BT only) The motor is not supplied	⇒	Verify the motor connections.
9)	(BT only) The traction motor carbon brushes are worn out	⇒	Replace the carbon brushes (see section 8.4.2 at page 61).
10)	(BT only) The traction motor is supplied but it doesn't work	⇒	Replace the traction motor (see section 4.4.4 at page 31).

The machine doesn't move straight

1)	The parking brake is engaged	⇒	Release the brake.
2)	The brush is not properly engaged	⇒	Release the brush and engage it properly.
3)	The brush deck is not properly adjusted	⇒	Adjust properly the brush deck (see section 6.2 at page 48).

3.5 Solution delivery system: what to do if...

The delivered solution is not correct or not enough		
1)	The machine is switched off	⇒ <i>Switch on the machine.</i>
2)	The machine doesn't switch on	⇒ <i>Refer to the proper section (see section 3.1 at page 10).</i>
3)	The solution tank is empty	⇒ <i>Fill up the solution tank.</i>
4)	(DS only) The chemical tank is empty	⇒ <i>Fill up the chemical tank.</i>
5)	The water flow is adjusted at minimum	⇒ <i>Increase the water flow adjustment.</i>
6)	(DS only) The membrane pump doesn't work	⇒ <i>Check the membrane pump connections and, if necessary, replace it (see section 4.5.6 at page 35).</i>
7)	(DS only) The one way valve doesn't pass the chemical	⇒ <i>Check the opening adjustment of the valve and, if necessary, replace it.</i>
8)	(DS only) The flojet pump doesn't work	⇒ <i>Check the flojet pump connections and, if necessary, replace it (see section 4.5.5 at page 34).</i>
9)	The solenoid valve doesn't work	⇒ <i>Check the solenoid valve connections and, if necessary, replace it (see section 4.5.7 at page 35).</i>
10)	The solution filter is stuck	⇒ <i>Clean the solution filter.</i>
11)	The display shows an alarm message	⇒ <i>Check what alarm message is shown and solve the related issue by following the proper instructions (see section 5.6 at page 45).</i>
12)	The detergent doesn't fit the type of dirt	⇒ <i>Replace the detergent with a proper one.</i>

Chapter 4

Disassembling Procedures

WARNING: BEFORE TO PERFORM ANY OPERATION DESCRIBED BELOW VERIFY THAT THE MACHINE TANKS ARE COMPLETELY EMPTY, THE MACHINE HAS TO BE TURNED OFF. DISCONNECT THE BATTERIES AND REMOVE THEM FROM THE MACHINE. AT LAST, VERIFY THAT THE PARKING BRAKE IS ENGAGED AND THE MACHINE IS IN A TOTALLY SAFE CONDITION.

4.1 Electrical Installation

4.1.1 Upper Handle

- Put the machine in safe conditions.
- Loose the screws that block the upper Handle to the lower handle (see fig. 4.1.1-1).
- Unplug the cables connected to the devices on the upper Handle.
- Remove the hinge pin and remove the handlebar (see fig. 4.1.1-2).
- Proceed at reverse to refit the part.

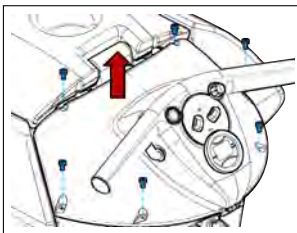

4.1.1-1

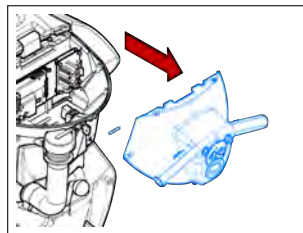

4.1.1-2

4.1.2 Main Card

- Put the machine in safe conditions.
- Open the upper handle by removing the screws.
- Unplug the cables connected to the Main Card (Rif.15) (see section 5.3.1 at page 39).
- Loose the screw that block the Main Card to the Lower handle and remove the card (see fig. 4.1.3-3).
- Proceed at reverse to refit the part.

4.1.3 BDI (Battery Discharge Indicator)

- Put the machine in safe conditions.
- Open the upper handle by removing the screws.
- Unplug the multipolar connector from the BDI (Rif.5) (see section 5.3.1 at page 39).
- Loose the knobs that block the BDI to its bracket.
- Remove the BDI from the upper handle (see fig. 4.1.3-4).
- Proceed at reverse to refit the part.

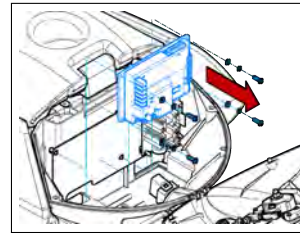

4.1.3-3

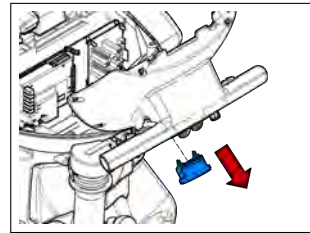

4.1.3-4

4.1.4 Key Switch

- Put the machine in safe conditions.
- Open the upper handle by removing the screws.
- Unplug the cables connected to the key switch (Rif.4) (see section 5.3.1 at page 39).
- Loose the ring that blocks the Key Switch to the Lower handle (see fig. 4.1.5-5).
- Remove the Key Switch.
- Proceed at reverse to refit the part.

4.1.5 Dead Man Microwitch

- Put the machine in safe conditions.
- Open the upper handle by removing the screws.
- Unplug the cables connected to the microswitch (Rif.7;8) (see section 5.3.1 at page 39).
- Remove the screws that secure the microswitch to its support (see fig. 4.1.5-6).
- Remove the Dead Man Switch.
- Proceed at reverse to refit the part.

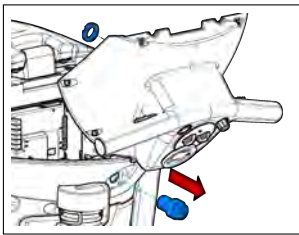

4.1.5-5

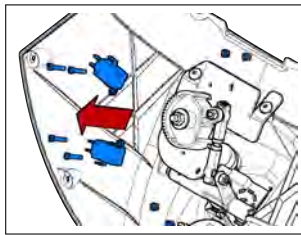

4.1.5-6

4.1.6 Traction control Cam and Levers

- Put the machine in safe conditions.
- Open the upper handle by removing the screws.
- Remove the nuts and screws that connect the levers to the cam and remove the levers.
- Remove the nut that connects the cam to the head of the control rod and remove the cam (see fig. 4.1.7-7).
- Proceed at reverse to refit the part.

4.1.7 ECO/Brush release Button

- Put the machine in safe conditions.
- Open the upper handle by removing the screws.
- Unplug the cables connected to the button (Rif.10) (see section 5.3.1 at page 39).
- Loose the ring that blocks the button to the Upper handle (see fig. 4.1.7-8).
- Remove the button.
- Proceed at reverse to refit the part.

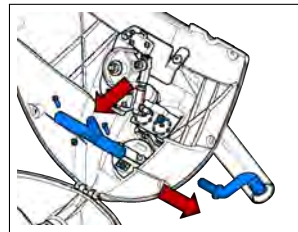

4.1.7-7

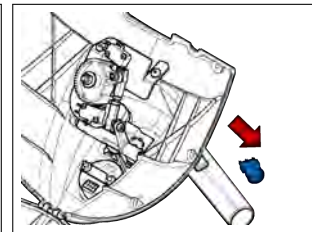

4.1.7-8

4.1.8 Potentiometer (BT only)

- Put the machine in safe conditions.
- Open the upper handle by removing the screws.
- Disconnect the wires from the potentiometer by cutting them (Rif.11) (see section 5.3.1 at page 39).
- Slip out the Potentiometer Adjuster Knob (it's fit with pressure).
- Loose the ring that blocks the potentiometer to the Upper handle.
- Remove the Potentiometer (see fig. 4.1.8-9).
- Proceed at reverse to refit the part taking care to solder the wires.

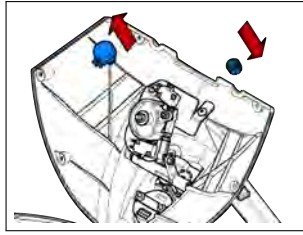

4.1.8-9

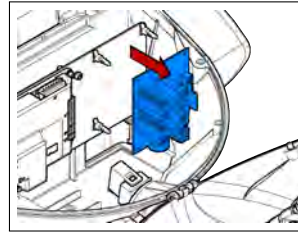

4.1.10-10

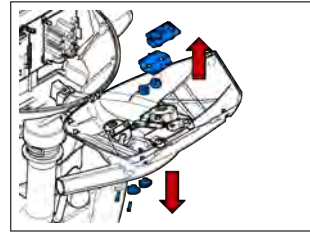

4.1.10-11

4.1.9 Pumps Card (DS only)

- Put the machine in safe conditions.
- Open the upper handle by removing the screws.
- Unplug the cables connected to the card (Rif.13) (see section 5.3.1 at page 39).
- Remove the card from the quick fasteners (see fig. 4.1.10-10).
- Proceed at reverse to refit the part.

4.1.10 Pumps Control Card (DS only)

- Put the machine in safe conditions.
- Open the upper handle by removing the screws.
- Remove the traction control Cam and Levers (see section 4.1.6 at page 19).
- Unplug the flat cable from the card (Rif.12) (see section 5.3.1 at page 39).
- Slip out the water and chemical Adjuster Knobs (they are fit with pressure).
- Remove the nuts that secure the card support to the upper handle.
- Remove the nuts that secure the pumps control card to the support (see fig. 4.1.10-11).
- Proceed at reverse to refit the part.

4.1.11 Brush deck Microswitch

- Put the machine in safe conditions.
- Lower the brush deck in working condition.
- Release the micro switch cables from the clamps.
- Unplug the cables connected to the micro switch (Rif.9) (see section 5.3.1 at page 39).
- Loose the screws that secure the micro switch from the machine frame.
- Remove the micro switch.
- Proceed at reverse to refit the part.

4.1.12 Squeegee Microswitch

- Put the machine in safe conditions.
- Lift the recovery tank.
- Release the micro switch cables from the clamps and the protection sheath.
- Unplug the cables connected to the micro switch (Rif.6) (see section 5.3.1 at page 39).
- Loose the screws that secure the micro switch to its support.
- Remove the micro switch.
- Proceed at reverse to refit the part.

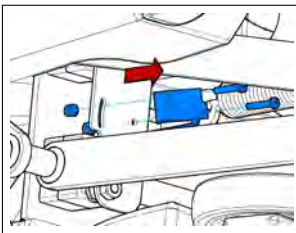

4.1.12-12

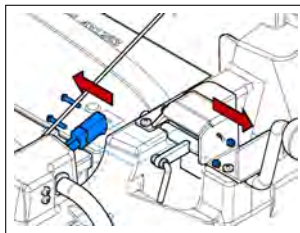

4.1.12-13

4.1.13 Complete Handle

- Put the machine in safe conditions.
- Unhook the drain hose from the clip and lay it on the ground.
- Remove the Suction Cap (see section 4.3.6 at page 27).
- Remove the rear screws that secure the complete handle to the recovery tank.
- Remove the upper screws that secure the complete handle to the recovery tank.
- Remove the complete handle (see fig. 4.1.14-14).
- Proceed at reverse to refit the part.

4.1.14 Battery Charger (CB only)

- Put the machine in safe conditions.
- Open the upper handle by removing the screws.
- Disconnect the power cables of the charger from the electrical harness (Rif.2) (see section 5.3.1 at page 39).
- Disconnect the safety cables of the charger from the electrical harness.
- Open the glove compartment.
- Loose the screws that block the Battery Charger to the lower handle and remove it (see fig. 4.1.14-15).
- Proceed at reverse to refit the part.

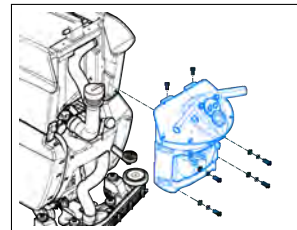

4.1.14-14

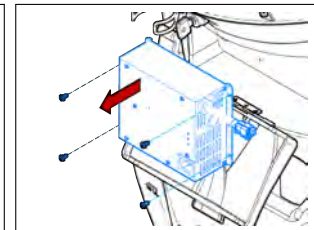

4.1.14-15

4.2 Mechanical Friction System

4.2.1 Brush Deck Assembly (MMx 50)

- Release the brush from the Brush Deck (see fig. 4.2.1-16).
- Put the machine in safe conditions.
- Lower the brush deck in working condition (see fig. 4.2.1-17).
- Remove the front carter (see fig. 4.2.1-18).
- Remove the Knob for the Adjustment of the Machine Direction (No traction version only) (see fig. 4.2.1-18).
- Unplug the Gearmotor Electrical Connector and the Solenoid Valve Connector.
- Unplug the Solution Hose from the solenoid valve (see fig. 4.2.1-19).
- Remove the screws that secure the Brush Deck to the Lifting Arms (see fig. 4.2.1-20) (see fig. 4.2.1-21).
- Remove the Brush Deck Bushings.
- Remove the Complete Brush Deck with a slight inclination.
- Proceed at reverse to refit the part.

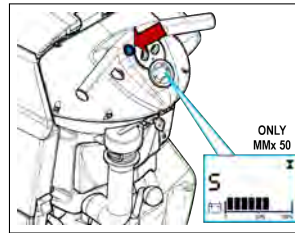

4.2.1-16

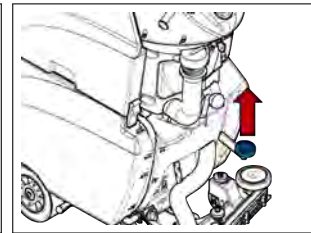

4.2.1-17

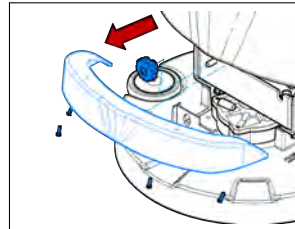

4.2.1-18

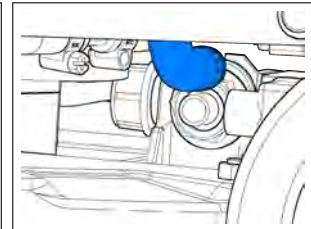

4.2.1-19

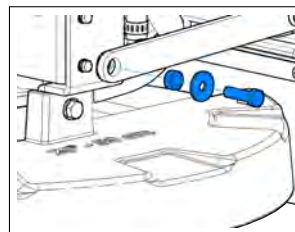

4.2.1-20

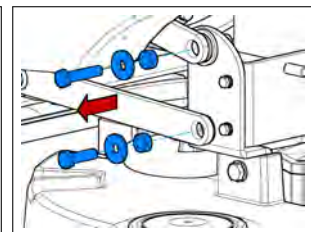

4.2.1-21

4.2.2 Brush Deck Assembly (MMx 52)

- Release the brushes from the Brush Deck (see fig. 4.2.2-22).
- Put the machine in safe conditions.
- Lower the brush deck in working condition.
- Remove the front carter (see fig. 4.2.1-18).
- Unplug the Motor Electrical Connector and the Solenoid Valve Connector.
- Unplug the Solution Hose from the solenoid valve (see fig. 4.2.2-24).
- Remove the screws that secure the Brush Deck to the Lifting Arms (see fig. 4.2.2-25) (see fig. 4.2.2-26).
- Remove the Brush Deck Bushings.

- Remove the Complete Brush Deck with a slight inclination (see fig. 4.2.2-27).
- Proceed at reverse to refit the part.

Note: Before to refit the part lubricate the thread in order to prevent blockages because of dirt or oxide.

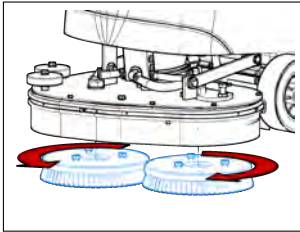

4.2.2-22

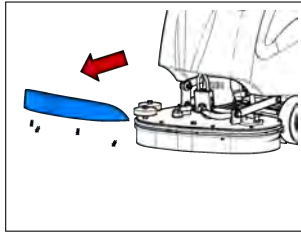

4.2.2-23

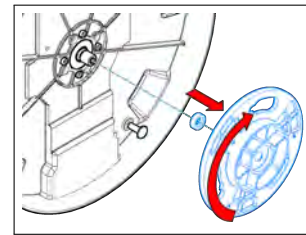

4.2.3-28

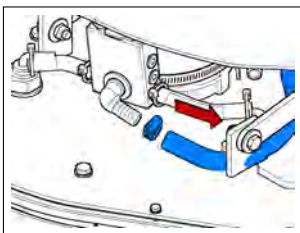

4.2.2-24

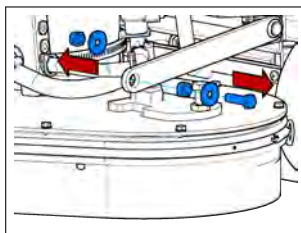

4.2.2-25

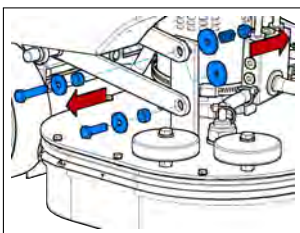

4.2.2-26

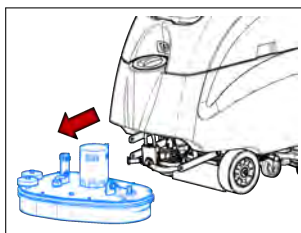

4.2.2-27

4.2.3 Brush Coupling Flange (MMx 50)

- Put the machine in safe conditions.
- Disassemble the Brush Deck from the machine (see section 4.2.1 at page 22).
- Put the Brush Deck to let the Gear-motor Head touch the floor.
- Unscrew the Coupling Flange rotating it in the same direction as the brush in standard working conditions (see fig. 4.2.3-28).
- Remove the spacer.
- Proceed at reverse to refit the part.

4.2.4 Brush Coupling Pulley (MMx 52)

- Put the machine in safe conditions.
- Disassemble the Brush Deck from the machine (see section 4.2.2 at page 22).
- Put the Brush Deck to let the motor Head touch the floor.
- Remove the brush deck lower carter (see fig. 4.2.4-29).
- Loosen the belt through the tension spring (see fig. 4.2.4-30).
- Unscrew the pulley fixing shaft and its nut taking care to spacers and bearings (see fig. 4.2.4-31).
- Remove the pulley.
- Proceed at reverse to refit the part.

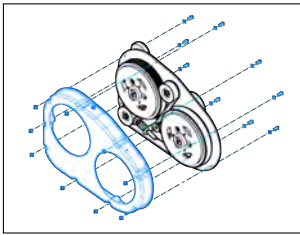

4.2.4-29

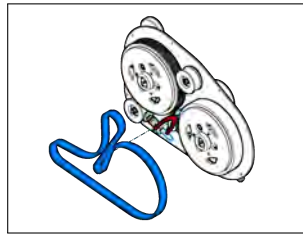

4.2.4-30

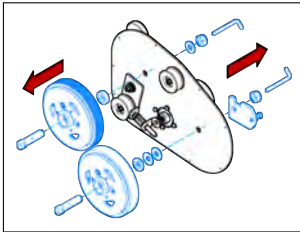

4.2.4-31

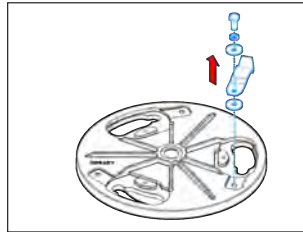

4.2.4-32

4.2.5 Brush Stopper Spring

- Put the machine in safe conditions.
- Disassemble the Brush Coupling Flange/Pulley (see section 4.2.3 at page 23) (see section 4.2.4 at page 23).
- Loose the screw that blocks the Brush Stopper Spring to the Flange/Pulley.
- Remove the Brush Stopper Spring (see fig. 4.2.4-32).
- Proceed at reverse to refit the part.

4.2.6 Brush Gearmotor (MMx 50)

- Put the machine in safe conditions.
- Disassemble the Brush Coupling Flange (see section 4.2.3 at page 23).
- Unplug the Solution Hose that connects the Solenoid Valve to the Brush Gearmotor (see fig. 4.2.6-33).
- Loose the 4 blocking screws and remove the Brush Gearmotor (see fig. 4.2.6-34).
- Proceed at reverse to refit the part taking care to use the countersunk holes.

Note: Use the thread lock liquid on the screw during the assembling.

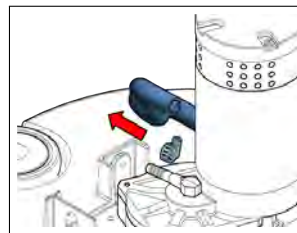

4.2.6-33

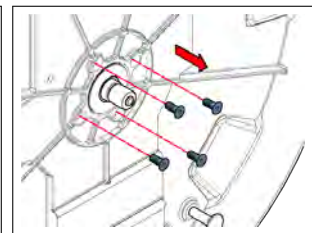

4.2.6-34

4.2.7 Brush Motor (MMx 52)

- Put the machine in safe conditions.
- Disassemble the Brush Deck from the machine (see section 4.2.2 at page 22).
- Remove the Smooth brush coupling Pulley (see section 4.2.4 at page 23).
- Loose the 4 blocking screws and remove the motor (see fig. 4.2.7-35).
- Remove the pulley from the motor shaft taking care to the key (see fig. 4.2.7-36).
- Proceed at reverse to refit the part.

Note: Use the thread lock liquid on the screw during the assembling.

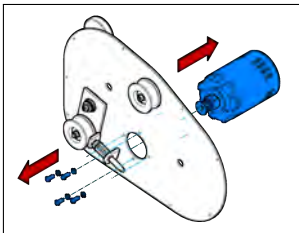

4.2.7-35

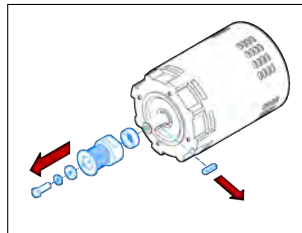

4.2.7-36

4.2.8 Bumper Wheel (MMx 50)

- Release the Brush from the Brush deck.
- Put the machine in safe conditions.
- Make sure the brush deck is lifted.
- Loose the upper bushing of the Bumper Wheel (see fig. 4.2.9-37)
- Remove the Bumper Wheel.
- Proceed at reverse to refit the part.

Note: Use the thread lock liquid on the screw during the assembling.

4.2.9 Bumper Wheel (MMx 52)

- Put the machine in safe conditions.
- Unscrew the screw that secures the Bumper Wheel and remove it (see fig. 4.2.9-38).
- Proceed at reverse to refit the part.

Note: Use the thread lock liquid on the screw during the assembling.

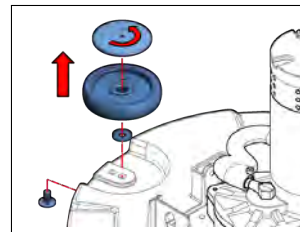

4.2.9-37

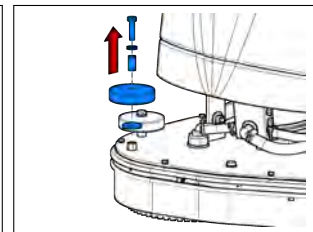

4.2.9-38

4.3 Drying System

4.3.1 Squeegee

- Put the machine in safe conditions.
- Lower the Squeegee in working conditions.
- Unplug the Vacuum Hose from the squeegee (see fig. 4.3.1-39).
- Loosen the knobs that block the Squeegee to the Squeegee Support (see fig. 4.3.1-39).
- Remove the Squeegee from the Squeegee Support (see fig. 4.3.1-40).
- Proceed at reverse to refit the part.
- Perform the adjustment procedure for the Squeegee (see section 7.3.1 at page 55).

Note: The Squeegee has to be refit on the machine with the washers on the upper part of the Squeegee Support (see fig. 4.3.1-41).

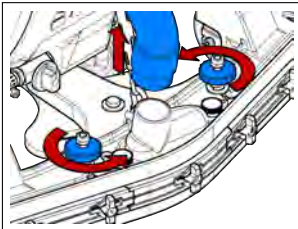

4.3.1-39

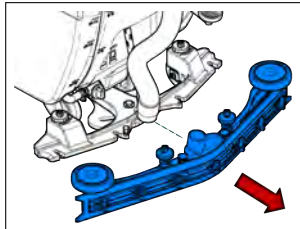

4.3.1-40

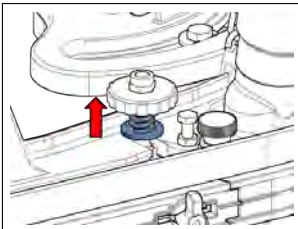

4.3.1-41

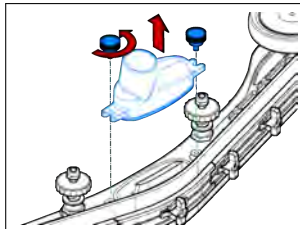

4.3.1-42

4.3.2 Squeegee Adapter

- Put the machine in safe conditions.
- Disassemble the Squeegee from the Machine (see section 4.3.1 at page 26).
- Loosen the knobs that block the Squeegee to the Squeegee Support (see fig. 4.3.1-42).
- Remove the Squeegee Adapter.
- Proceed at reverse to refit the part.

4.3.3 Squeegee Support

- Put the machine in safe conditions.
- Disassemble the Squeegee from the Machine (see section 4.3.1 at page 26).
- Remove the split Pin that fix the lifting chain to the Squeegee Support (see fig. 4.3.3-43).
- Loosen the screws and the nuts that block the Squeegee Support to the Squeegee Rotation Arm (see fig. 4.3.3-44).
- Remove the Squeegee Support (see fig. 4.3.3-45).
- Proceed at reverse to refit the part, paying attention to take care about the bushing positioning.

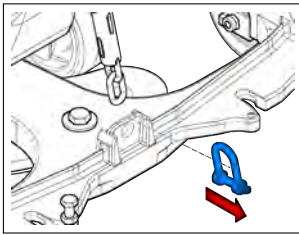

4.3.3-43

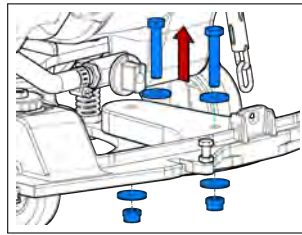

4.3.3-44

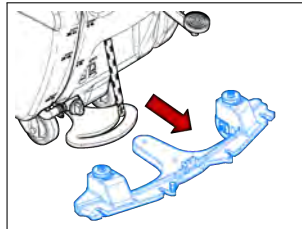

4.3.3-45

4.3.4 Squeegee Rotation Arm

- Put the machine in safe conditions.
- Remove the squeegee support (see section 4.3.3 at page 26) (see fig. 4.3.4-46).
- Remove the screw that fix the Squeegee Rotation Arm to the machine frame (see fig. 4.3.4-47).
- Remove the squeegee rotation arm and the compression spring.
- Proceed at reverse to refit the part paying attention to the correct positioning of the bushings.

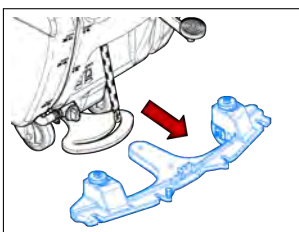

4.3.4-46

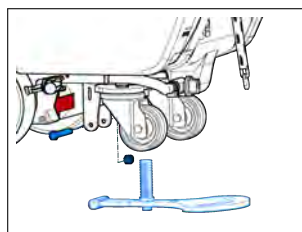

4.3.4-47

4.3.5 Squeegee adjustment wheels

- Put the machine in safe conditions.
- Remove the squeegee support (see section 4.3.3 at page 26).
- Remove the squeegee adjustment knob and the spring (see fig. 4.3.5-48).
- Remove the Adjustment Wheel Assembly.
- Unscrew the fixing screw of the wheel to the support (see fig. 4.3.5-49).
- Proceed at reverse to refit the part.

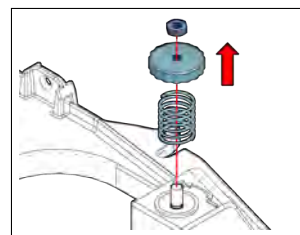

4.3.5-48

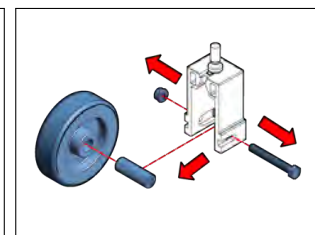

4.3.5-49

4.3.6 Vacuum Cover

- Put the machine in safe conditions.
- Remove the screws securing the vacuum motor carter (see fig. 4.3.6-50).
- Disconnect the electrical connector for power supply.
- Remove the fixing screws of support platelets of the vacuum cover and remove it (see fig. 4.3.6-51).
- Proceed at reverse to refit the part.

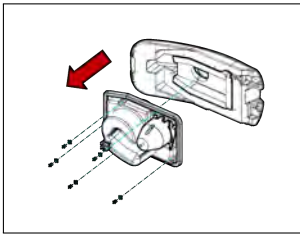

4.3.6-50

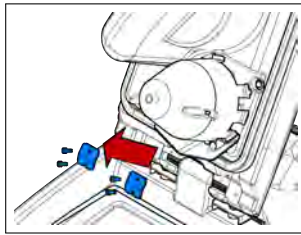

4.3.6-51

4.3.7 Vacuum Hose

- Put the machine in safe conditions.
- Unplug the Vacuum Hose from the Squeegee (see fig. 4.3.7-52).
- Remove the complete handle (see section 4.1.13 at page 21).
- Uncouple the Vacuum Hose from the Recovery tank upper Inlet (see fig. 4.3.7-53).
- Proceed at reverse to refit the part.

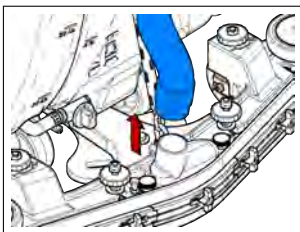

4.3.7-52

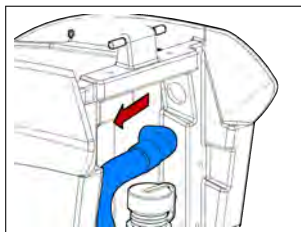

4.3.7-53

4.3.8 Recovery Tank

- Put the machine in safe conditions.
- Remove the Vacuum cover (see section 4.3.6 at page 27).
- Remove the complete handle from the machine (see section 4.1.13 at page 21).
- Lift the recovery tank.
- Unplug the Vacuum hose and the Drain hose from the Recovery Tank (see fig. 4.3.8-54).
- Release the harness from the plastic clamps.
- Remove the screw that secures the retaining rope of the recovery tank.
- Remove the front plate of the tank fixing pin (see fig. 4.3.8-55).
- Lower the recovery tank.
- Unscrew the back threaded pin from the tank.
- Remove the recovery tank from the machine.
- Proceed at reverse to refit the part.

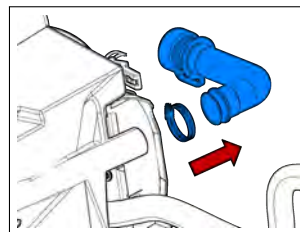

4.3.8-54

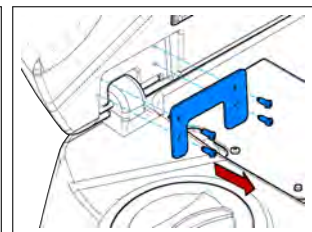

4.3.8-55

4.3.9 Drain Hose

- Put the machine in safe conditions.
- Lift the recovery tank.
- Loosen the clamp that blocks the Drain Hose to the Recovery Tank (see fig. 4.3.8-54).
- Unplug the Drain Hose from the recovery tank.
- Proceed at reverse to refit the part.

4.3.10 Vacuum Filter

- Put the machine in safe conditions.
- Lift the vacuum cover from the recovery tank.
- Uncouple the Filter Cover.
- Remove the Vacuum Filter and its strap by pulling it down (see fig. 4.3.10-56).
- Proceed at reverse to refit the part.

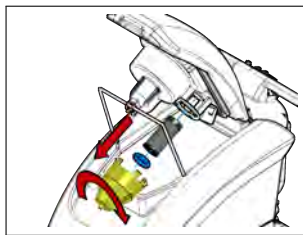

4.3.10-56

4.3.11 Vacuum Motor

- Put the machine in safe conditions.
- Remove the screws securing the vacuum motor carter (see fig. 4.3.11-57).
- Disconnect the electrical connector of the Vacuum Motor.
- Remove the vacuum motor (see fig. 4.3.11-58) (see fig. 4.3.11-59).
- Proceed at reverse to refit the part.

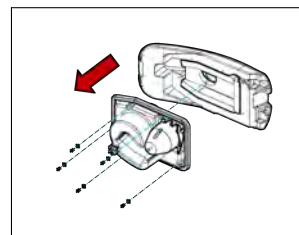

4.3.11-57



4.3.11-58

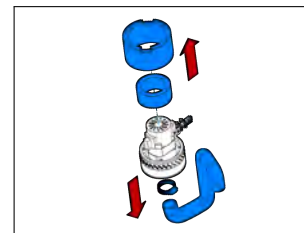

4.3.11-59

4.3.12 Squeegee Lifting Chain

- Put the machine in safe conditions.
- Disassemble the Squeegee from the Machine (see section 4.3.1 at page 26).
- Open the fork's clip that secures the lifting chain to the Squeegee lifting lever hook (see fig. 4.3.12-60).
- Remove the split Pin that fix the lifting chain to the Squeegee Support (see fig. 4.3.12-61).
- Remove the Squeegee Lifting Chain.
- Proceed at reverse to refit the part.

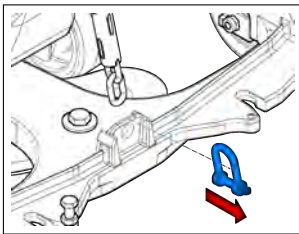

4.3.12-60

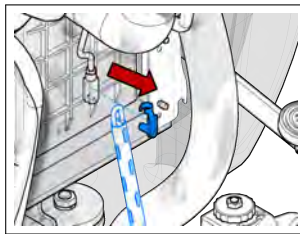

4.3.12-61

4.3.13 Squeegee Lifting Lever

- Put the machine in safe conditions.
- Lift the recovery tank.
- Remove the squeegee microswitch (see section 4.1.12 at page 21).
- Loosen the screw that secures the lifting hook to the lever.
- Remove the support cover by unscrewing the fixing screws.
- Remove the Squeegee Lifting Lever from the Machine (see fig. 4.3.13-62).
- Proceed at reverse to refit the part.

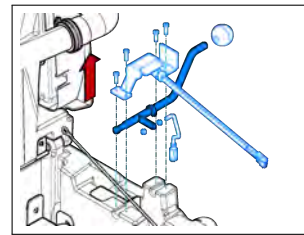

4.3.13-62

4.4 Frame and Traction System

4.4.1 Front Wheels

- Put the machine in safe conditions.
- Lift up the wheel from the ground.
- Loose the screw that blocks the wheel to the Drive Shaft (see fig. 4.4.2-63).
- Remove the wheel pulling it by hands or using a extractor.
- Proceed at reverse to refit the part (Use the thread lock liquid on the screw during the assembling).

4.4.2 Traction Front Wheels (BT only)

- Put the machine in safe conditions.
- Lift up the wheel from the ground.
- Loose the screw that blocks the wheel to the Drive Shaft (see fig. 4.4.2-64).
- Remove the wheel pulling it by hands or using a extractor.
- Proceed at reverse to refit the part (Use the thread lock liquid on the screw during the assembling).

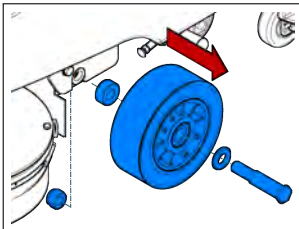

4.4.2-63

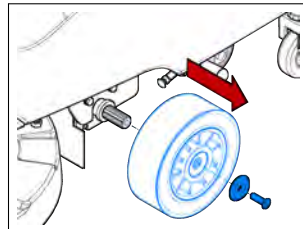

4.4.2-64

4.4.3 Rear Wheels

- Put the machine in safe conditions.
- Lift up the rear wheels from the ground.
- Remove the screw and nut securing the wheel to the frame (see fig. 4.4.3-65).
- Remove the wheel.
- Proceed at reverse to refit the part (Use the thread lock liquid on the screw during the assembling).

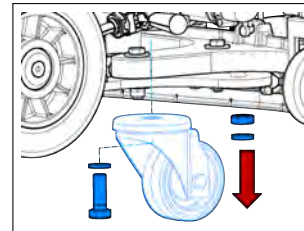

4.4.3-65

4.4.4 Gearmotor and Drive Shafts (BT only)

- Put the machine in safe conditions.
- Remove the Front wheels (see section 4.4.2 at page 31).
- Disconnect the electrical connector of the traction gearmotor.
- Remove the spacer and the screws fixing the gearmotor to the machine frame (see fig. 4.4.4-66).
- Open the bearings support removing the screws (see fig. 4.4.4-67).
- Remove the traction gearmotor (see fig. 4.4.4-68).
- Remove the drive shafts from the traction motor pulling them by hands or using an extractor (see fig. 4.4.4-69).

- Remove the bearings from the Drive Shafts using an extractor (see fig. 4.4.4-69).
- Proceed at reverse to refit the part.

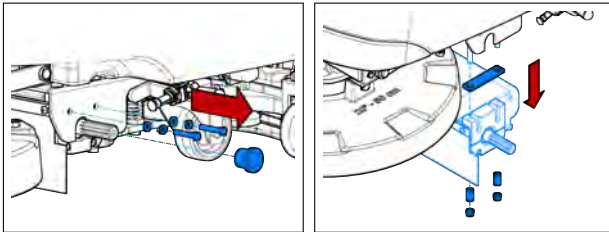

4.4.4-66

4.4.4-67

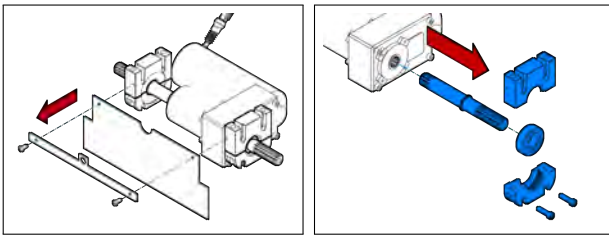

4.4.4-68

4.4.4-69

4.4.5 Parking Brake

- Put the machine in safe conditions.
- Remove the screws that secure the Parking Brake to the machine frame and remove the brake.
- Proceed at reverse to refit the part.

4.5 Solution Delivery System

4.5.1 Solution Tank

- Put the machine in safe conditions.
- Remove the recovery tank (see section 4.3.8 at page 28).
- Disconnect the water supply hose from the solenoid valve.
- Remove the dosing system if present (see fig. 4.5.1-70) (see fig. 4.5.1-71) (see fig. 4.5.1-72).
- Disconnect the solution supply hose from the water valve (see fig. 4.5.1-73).

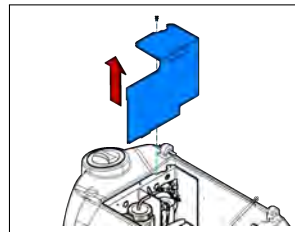

4.5.1-70

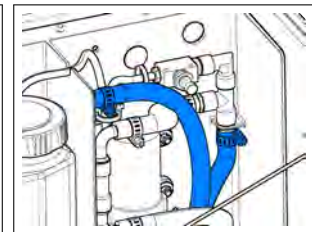

4.5.1-71

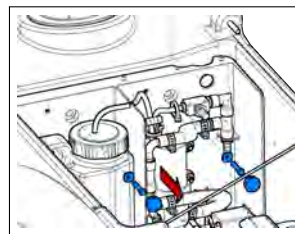

4.5.1-72

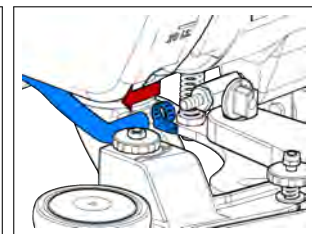

4.5.1-73

- Remove the dosing system housing and the battery tray (see fig. 4.5.1-74).
- Open the fork's clip that secures the lifting chain to the Squeegee lifting lever hook (see fig. 4.5.1-75).
- Remove the split Pin that fix the lifting chain to the Squeegee Support (see fig. 4.3.12-61).
- Remove the pedal and the pedal cover from the brush deck control lever (see fig. 4.5.1-76).

- Loosen the lower screws fixing the solution tank to the frame, near the rear wheels (see fig. 4.5.1-77).
- Passing through the battery compartment, unscrew the front screws fixing the solution tank to the frame near the front wheels (see fig. 4.5.1-78).
- Remove the solution tank (see fig. 4.5.1-79).
- Proceed at reverse to refit the part.

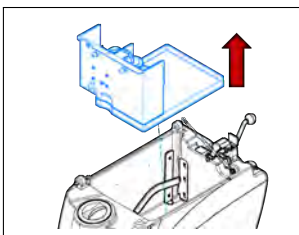

4.5.1-74

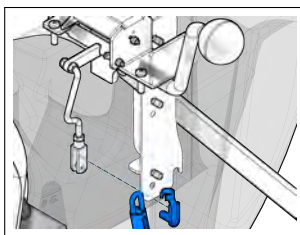

4.5.1-75

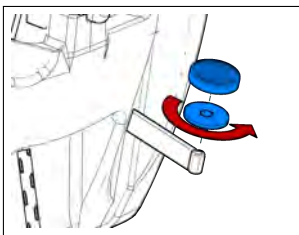

4.5.1-76

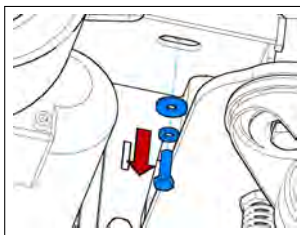

4.5.1-77

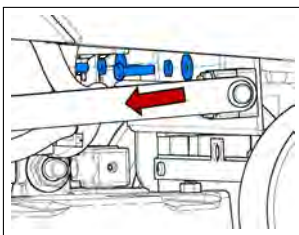

4.5.1-78

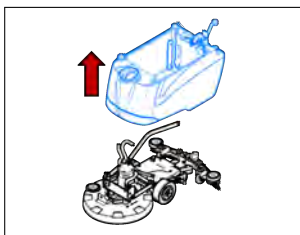

4.5.1-79

4.5.2 Hoses

- Put the machine in safe conditions.
- Loose the clamps that block the hose to the fitting.
- Slip off the hose from the fitting.
- Proceed at reverse to refit the part.

4.5.3 Solution Filter

- Put the machine in safe conditions.
- Loose the filter and remove it from its housing (see fig. 4.5.3-80).
- Slip off the OR gasket from the filter paying attention to not damage it.
- Proceed at reverse to refit the part.

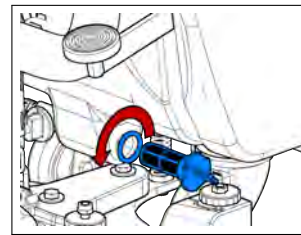

4.5.3-80

4.5.4 Water Valve

- Put the machine in safe conditions.
- Unplug the hose from the Water Valve losing the hose clamp.
- Unscrew the adjustment Water Valve from the tank (see fig. 4.5.4-81).
- Remove the fitting.
- Loosen the screw that fix the Adjustment Knob and remove the valve body from the Adjustment Knob.
- Proceed at reverse to refit the part (Use sealing liquid on the fitting to refit the part).

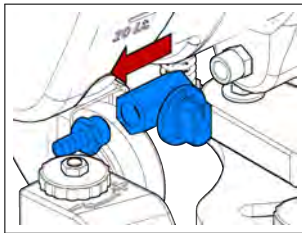

4.5.4-81

4.5.5 Flojet Pump

- Put the machine in safe conditions.
- Lift the recovery tank.
- Remove the pumps compartment cover by loosening the screw.
- Remove the pumps compartment from the tank by unscrewing the mounting screws underneath the protective caps (see fig. 4.5.5-82).
- Disconnect the hoses of the water system from the pump (see fig. 4.5.5-83).
- Disconnect the electrical wiring from the pump.
- Unscrew the fixing screws and remove the pump (see fig. 4.5.5-84).
- Proceed at reverse to refit the part.

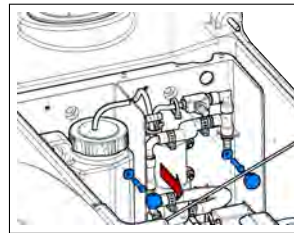

4.5.5-82

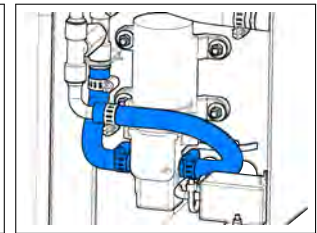

4.5.5-83

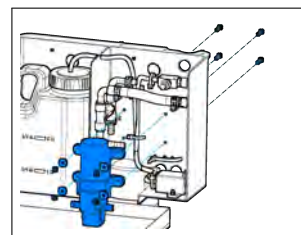

4.5.5-84

4.5.6 Membrane Pump

- Put the machine in safe conditions.
- Lift the recovery tank.
- Remove the pumps compartment cover by loosening the screw.
- Remove the pumps compartment from the tank by unscrewing the mounting screws underneath the protective caps (see fig. 4.5.6-85).
- Disconnect the hoses of the water system from the pump (see fig. 4.5.6-86).
- Disconnect the electrical wiring from the pump.
- Unscrew the fixing screws and remove the pump (see fig. 4.5.6-87).
- Proceed at reverse to refit the part.

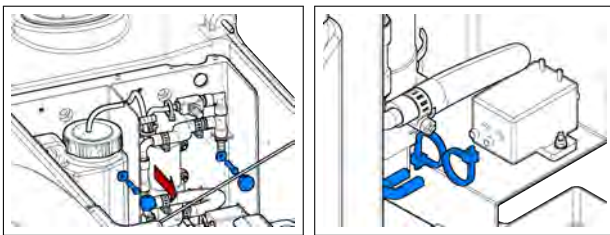

4.5.6-85

4.5.6-86

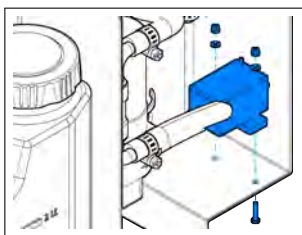

4.5.6-87

4.5.7 Solenoid Valve

- Put the machine in safe conditions.
- Lower the Brush Deck in working conditions.
- Unplug the hoses connected to the Solenoid Valve (see fig. 4.5.7-88) (see fig. 4.5.7-90).
- Loose the plastic nut that block the Solenoid Valve to its support (see fig. 4.5.7-89).
- Loose the solenoid Valve cap and remove the OR gasket (see fig. 4.5.7-91).
- Proceed at reverse to refit the part (Position the spacer washer properly to refit the valve).

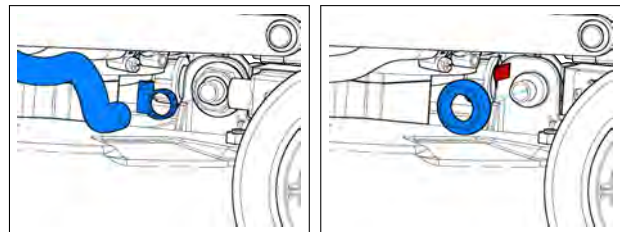

4.5.7-88

4.5.7-89

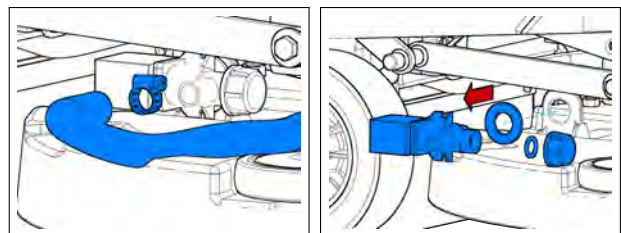

4.5.7-90

4.5.7-91

Part III
Machine Description

Chapter 5

Electrical System

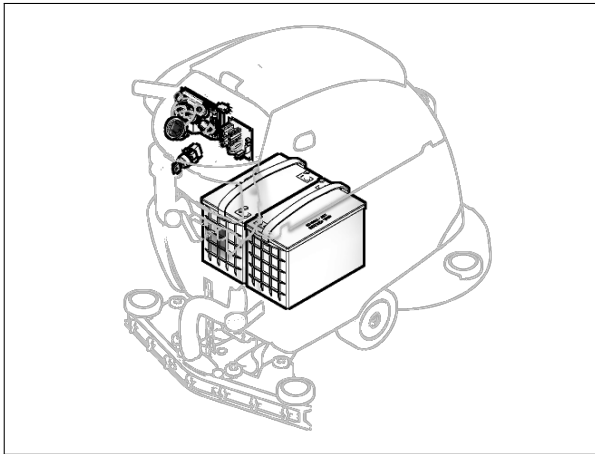

5.1 Structure

- Main Card
- Hourmeter/Display/Battery control card
- Key Switch
- Deadman Microswitch
- "ECO"/brush release Switch
- Speed Potentiometer
- Batteries
- Battery Charger

5.2 Description

A main card runs all the functions of the machine, traction, brush base, vacuum and water.

The BT versions feature a traction motor and a control for the speed adjusting.

The main card receive as input, all the information from the dashboard, the deadman micro and all the electronic devices of the machine.

These signals are translated from the main card to run correctly the scrubber dryer and to prevent any safety problem to the operator.

The Hourmeter of the machine has a triple function:

Hourmeter, to count the total number of worked hours of the machine.

Display, that allows to check the setting of the Main card and any alarm messages.

Battery Control card, to monitor the level of remaining charge.

5.3 Location of Electrical components

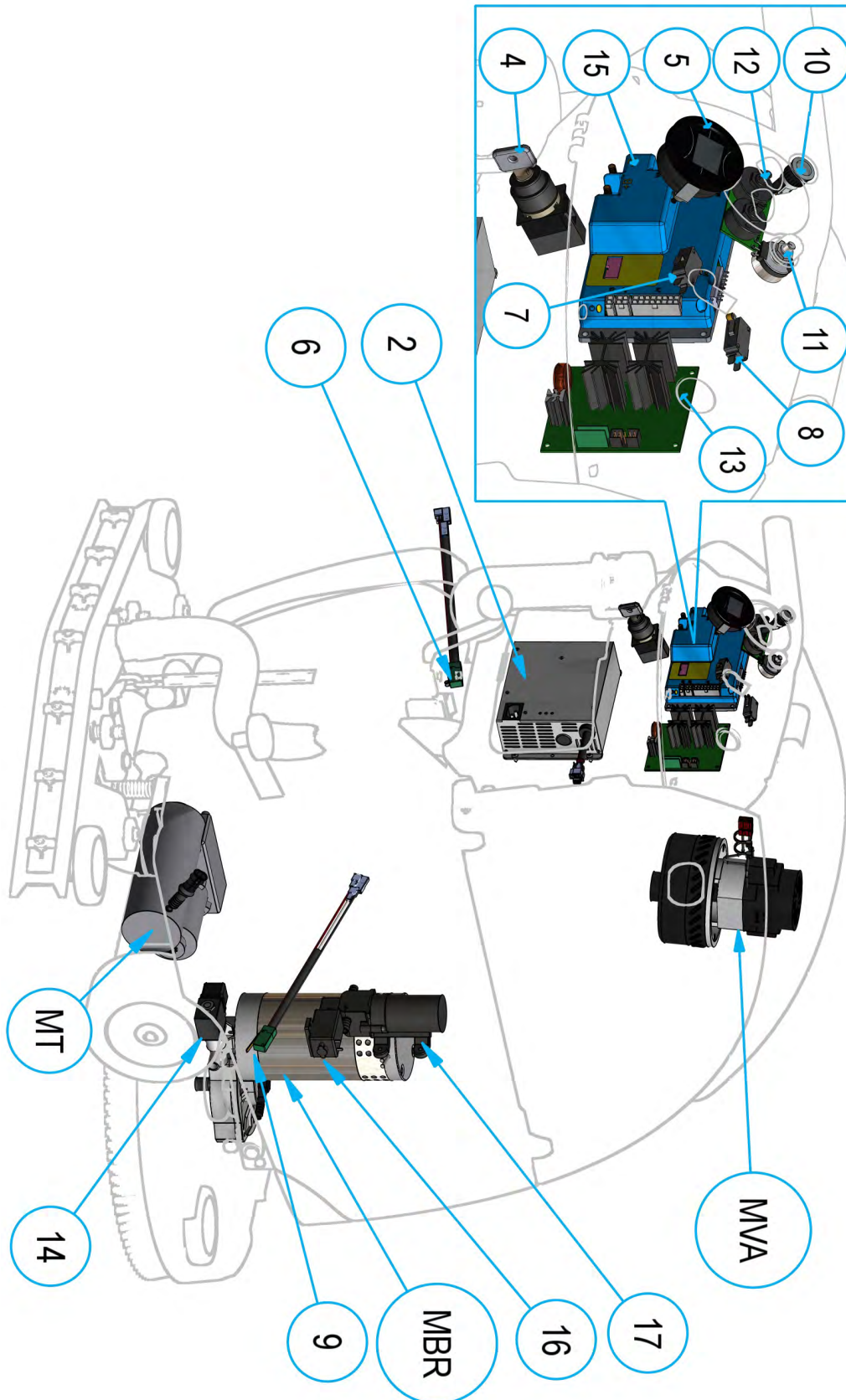

5.3.1 List of Components

- 2 Charger¹
- 4 Key Switch
- 5 Hourmeter and Battery control card
- 6 Vacuum Motor Microswitch
- 7 Forward Microswitch
- 8 Backward Microswitch
- 9 Brush Motor Microswitch
- 10 Brush Release Switch
- 11 Potentiometer²
- 12 Pumps Control Card³
- 13 Pumps Card³
- 14 Solenoid Valve
- 15 Main Card
- 16 Membrane Pump
- 17 Flojet Pump
- MT Traction Motor
- MBR Brush Gearmotor
- MVA Vacuum Motor

¹Optional

²BT only

³DS only

5.3.2 Main Card

The Main Card is the heart of the machine and, depending of the input information, decides how to use the devices of the machine during normal work. On the table here below, is possible to identify the input/output signals of the card.

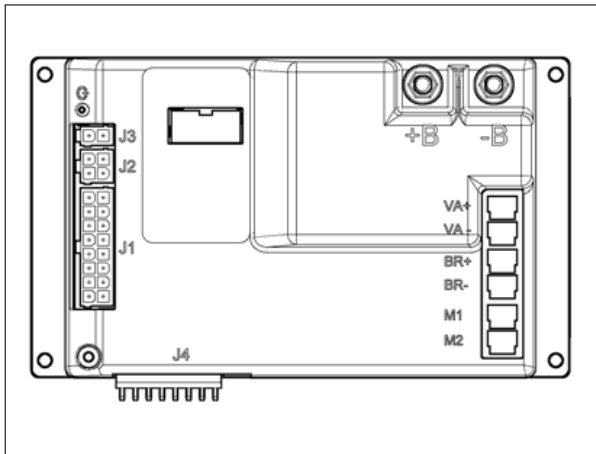

Main Card

Input & Output Signals

- J1 Input Signal from key
Charger
Deadman Microswitch
Potentiometer (BT only)
Brush Release Switch
Supply to the Solenoid
 - J2 Setup B/BT
 - J3 Supply to the Pumps card
 - VA Supply to Vacuum Motor
 - BR Supply to Brush Motor
 - M1 Supply to Traction Motor
 - M2 Supply to Traction Motor
-

5.3.3 Operator Lever Microswitches

The machine is equipped with one or more safety microswitches, located inside of the handle of the machine and operated by the levers. **These microswitches** runs the functionality of the hourmeter, the mechanical rubbing system and the machine traction if present (BT only).

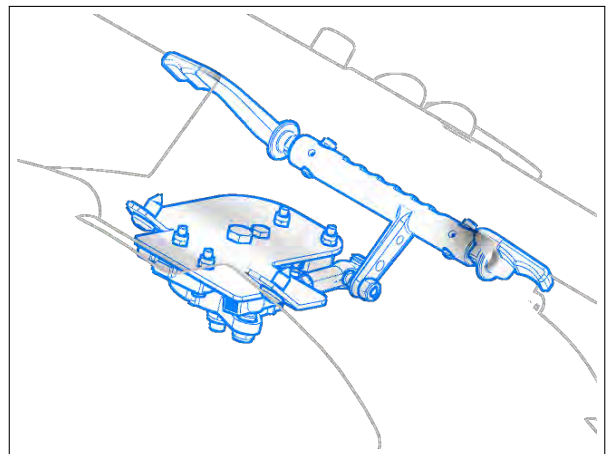

5.3.4 Potentiometer (BT only)

The adjustment knob of the potentiometer, located on the control panel, allows to adjust the speed of the machine, and send the appropriate control signals to the Main card.

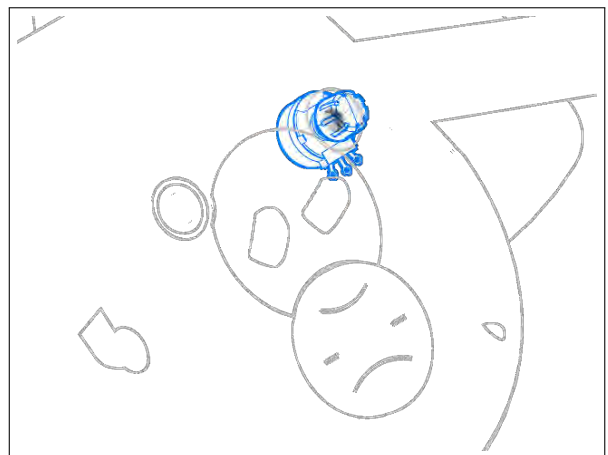

5.3.5 Hourmeter

The machine is equipped with an **electronic hourmeter** installed on the dashboard. The hourmeter shows the **total worked hours** of the machine and the **battery charge level** on the display. The hourmeter can stop the machine if the residual charge of the batteries is under a minimum threshold which could compromise its life cycle. **The hourmeter** can be set up according to the battery type fitted on the machine.

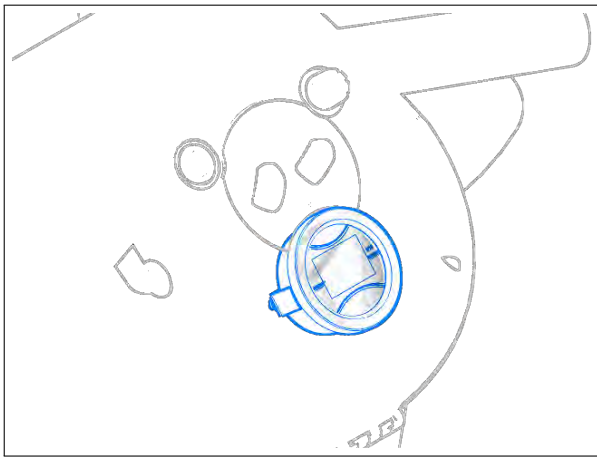

5.3.7 Pumps Control Card (DS only)

The machine is available with the chemical dosing system as optional. Thanks to the two knobs located on the control panel, it is possible to adjust both the amount of water and the chemical that is needed for the application.

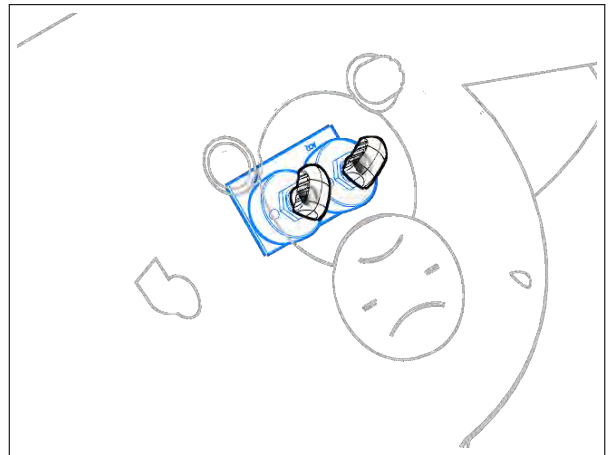

5.3.6 Batteries

On the machine is possible to install different type of batteries.

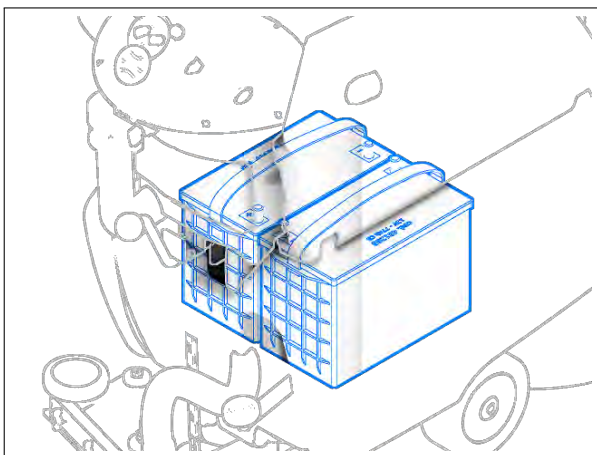

5.3.8 Charger

The charger is available as optional. The charger is placed inside the glove compartment of the machine, with free access to connect the charger to the power supply.

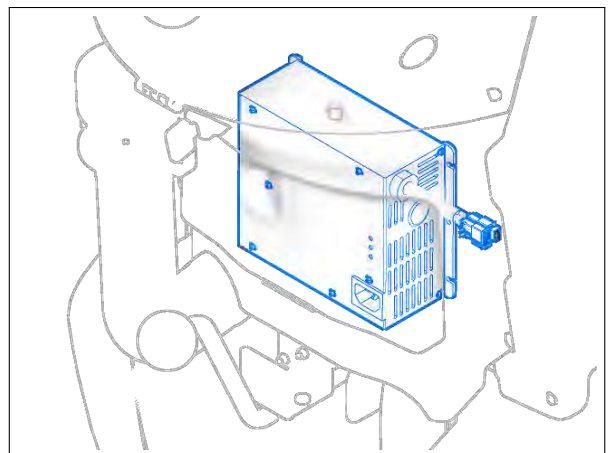

5.4 Adjustments

5.4.1 Operator Lever microswitches

Check the functionality and the status of the safety microswitches. When the microswitch is pressed, it have to remain **0,5 mm** of free space, between the lever and the microswitch. Check the functionality of the lever. If not working properly, replace the microswitch.

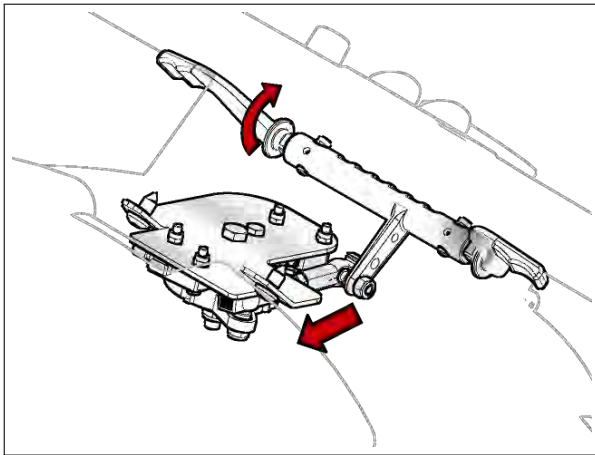

5.4.2 Battery Control Card

Check that, when switching on the machine, the battery control card (included in the hourmeter) has the following starting sequence:

- For the first 2 seconds, display the setting of the dip switches
- Then display the total worked hours and level of residual charge of the battery

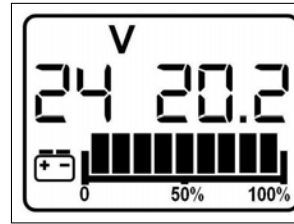

5.4.2-92 Switch On

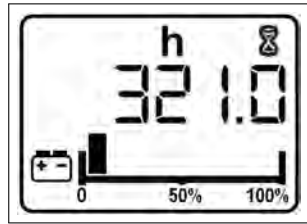

5.4.2-93 After 2 seconds

It is possible to check the settings of the battery control card, simply turning the machine on and check for the first 2 seconds the reading on the display. The value on the left indicates the rated voltage set for the battery (eg. 24V). The value on the right indicates the maximum threshold of discharge (eg. 20.2V).

For **Wet Cell** batteries the value of the right must be equal to **20.2V**, For **GEL/AGM** batteries instead, the value of the right must be equal to **21.8V**. To adjust the battery control card depending on the batteries installed, set the microswitch located behind the hourmeter, (Picture) as shown in the table.



Hourmeter Dip switch Setting						
1	2	3	4	5	6	Setup
OFF	ON	OFF	OFF	OFF	OFF	Wet Cell
OFF	ON	ON	OFF	OFF	OFF	GEL / AGM

5.4.3 Charger (CB)

The charger is located on the rear side of the machine and easy to access for the operator. When connected to the power supply, a red led will blink once, the yellow led blink once and the green led blink depending of the type of battery for which the charger is set.



A Proper Charging cycle follows the below phases order.

Phase	LED	Description
A	Red	Blinking, check of battery status
B	Red	First charging phase
C	Yellow	Second charging phase
D	Green	Charged battery

Check if the charger is properly set according to the installed batteries.

Charging curve Set Up

To set up the charger, follow the instructions:

- Use a screwdriver to remove the small black plastic cap.
- Set-up the internal dipswitches according to the following table.

The dipswitches are divided in two couple. The higher couple are the dipswitches 1 and 2, the couple down are the dipswitches 3 and 4. The following table shows how to setup the dipswitches 1 and 2

Set-up of Charging Curve			
DP1	DP2	Set-up	Flash
OFF	OFF	Wet cell batteries	1
ON	ON	Gel TROJAN	2
OFF	ON	Generic GEL or AGM batteries	3
ON	OFF	Gel EXIDE SON-NENSCHHEIN	4

DP3: OFF (not used)

DP4: OFF (not used)

Restore the the small black plastic cup.

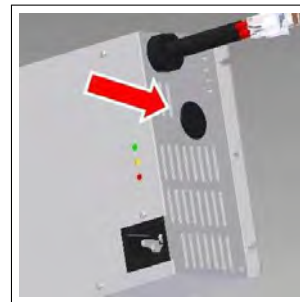

5.4.3-94 Cap

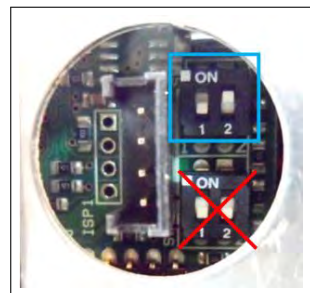

5.4.3-95 Dip switch

Error Codes of Charger

The charger have an alarm system. The alarm code is shown by blinks of the yellow led.

Error code	
Flash	Description
1	Wrong battery, Inverted polarity, short circuit to the exit
2	Timeout alarm, Defect of the battery
3	Defect of the Charger
4	Over temperature alarm

5.4.4 ECO Function

Press the ECO button, and let the vacuum motor and the brush motor work. With the ECO mode activated, check if the noise of the vacuum motor and the brush motor is reduced. Connect a Clamp meter to the positive cable of the batteries and check if the current consumption is less than normal function (without ECO mode).

ATTENTION: We don't give the amps values because it can change depending of the working conditions.

5.5 Maintenance and Checks

5.5.1 Electrical System

Check *(to perform every 150h)*

Check the functions and the proper connections of the switches, microswitches, motors, solenoid valve and battery loop cable. Check periodically, the wiring connections. To check the wiring, open the upper handle by removing the screws.

5.5.2 Batteries

Check *(to perform every 150h)*

Check the proper connection of the plug cable, the oxidation of the cables and the connectors.

5.6 Alarm Tables

Alarms of Over current and Temperature

Id Alarm	Meaning	Solution
ALL_01	Brush Amperage Protection	Check consumption of the brush motor. Detected high current on brush motor.
ALL_02	Vacuum Amperage Protection	Check consumption of the vacuum motor. Detected high current on vacuum motor.
ALL_03	Damage of Power	Damage power of brush or vacuum: replace the main card. This alarm could be shown also during the trailing of the machine.
ALL_04	Output over current on brush or vacuum	Detect a short circuit on output brush motor or vacuum motor: Check connections and motors.
ALL_05	Thermal protection on brush/vacuum	Over temperature of brush/vacuum motor: check consumption of motors.

Traction Alarms

Id Alarm	Meaning	Solution
ALL_14	Safety lever pressed before starting	Detected safety microswitch pressed before starting : release the safety lever.
ALL_15	Thermal protection on traction	Over temperature on traction : check consumption of traction motor (BT only).
ALL_16	Power of traction damage	Replace the main card. This alarm could be shown also during the trailing of the machine. (BT only)
ALL_17	Traction Over current	Detected a short circuit on the traction motor output: Check connections and traction motor (BT only).
ALL_18	Traction Amperage protection	Check how the traction function is used. Detected too high working current on traction motor (BT only).

General Alarms

Id Alarm	Meaning	Solution
ALL_20	Error reading internal memory	Replace the main card.
ALL_21	Error key sequence	Error on key signal: Check the key connection. Check, also, the batteries connections and main card
ALL_22	Damage of general relay	Check the traction motor connections. If the connection are OK, the general relay on the main card is damaged: replace the main card. The same alarm is present also if power fuse is damaged
ALL_23	Over voltage	Detected a over voltage on the main card. Check the batteries connections.
ALL_24	Battery not connected to the main card	Check the traction motor, Detected high voltage on traction motor (BT only)
ALL_25	No communication between control card and main card	Check the connections between control card and main card.

5.7 Technical Features

TECHNICAL DESCRIPTION	U/M	MMx50	MMx52
Dimension of Battery compartment (l x L x h)	mm	355x337x230	
Batteries Rated Voltage	V	24	
Maximum batteries weight	kg	66	

5.8 Recommended Spare Parts

PN	Description	MMx	
		50	52
210516	COMPLETE KEY SWITCH (ELFI D.22)	✓	✓
438057	MAIN CARD 7CFS0000	✓	✓
440063	ELECTRONIC HOURMETER D=51,5 L=25	✓	✓
216691	SQUEEGEE COMPLETE MICROSW.	✓	✓
216999	BRUSH DECK COMPLETE MICROSW.	✓	✓
409491	MICROSW.10A 3X22	✓	✓
428981	ECO/BRUSH RELEASE BUTTON	✓	✓
428665 ¹	POTENTIOMETER 2.5 KOHM	✓	✓
437657 ²	BATTERY CHARGER NE286 24V 11A	✓	✓
425593 ³	PUMPS CARD	✓	✓
427115 ³	PUMPS CONTROL CARD	✓	✓

¹BT Only

²CB Only

³DS Only

Chapter 6

Mechanical Rubbing System

6.1 Description

The washing function of the machine is obtained by the interaction of the cleaning solution with the dirt present on the floor.

To facilitate and enhance this interaction, is used a system of mechanical rubbing which consists in a device which rubs on the floor.

This device can be of various nature (pad or brush), in each case, its function is to mechanically remove the dirt from the ground and facilitate the reaction between the dirt and cleaning solution.

A direct current electric motor provides the rotational movement of the brush coupling flange.

To the flange is coupled the brush (or the pad holder provided with pad) that rotates together with the flange. After lowering the brush deck to the ground, the brush touches and rubs on the floor providing the desired mechanical rubbing.

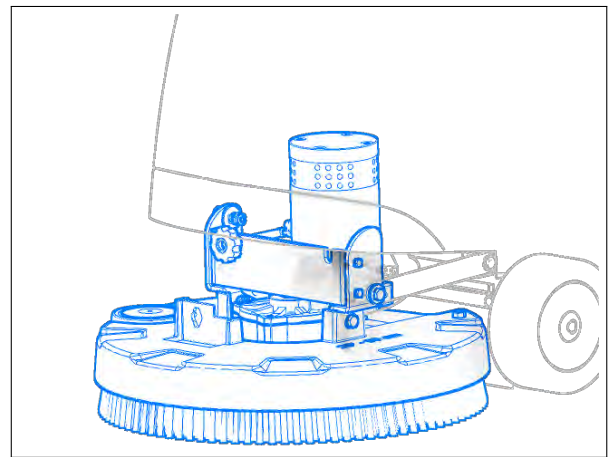

Figure 6.1: MMx 50 Brush Deck

6.1.1 Structure MMx50

- Gearmotor
- Brush Deck
- Brush coupling Flange
- Brass bushings
- Bumping Wheel

6.1.2 Description MMx 50

The brush deck of the 50 version is equipped with one disc brush.

It is composed from a deck on which is centrally fixed a gearmotor which threaded shaft connected to the flange provides the rotational movement.

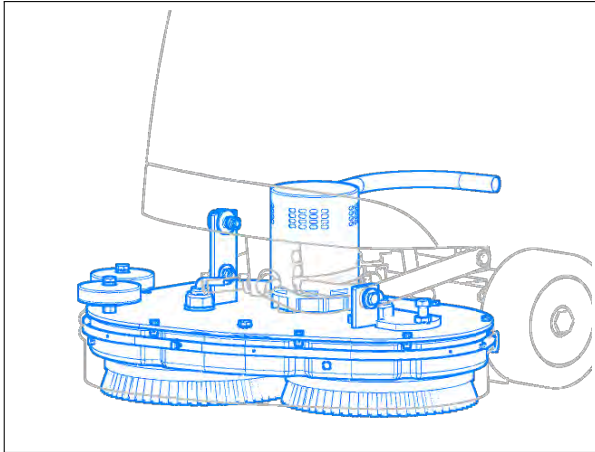

Figure 6.2: MMx 52 Brush Deck

6.1.3 Structure MMx 52

- Motor
- Brush Deck
- Brush coupling Pulleys
- Belt
- Brass bushings
- Bumping Wheels
- Splashguard carter

6.1.4 Description MMx 52

The brush deck of the 52 version is equipped with two disc brushes.

It is composed from a deck on which is centrally fixed a motor which threaded shaft connected to the brush coupling pulleys through a drive belt, provides the rotational movement.

6.2 Adjustments

The brush deck must be free to move pivoted to its support so that the brush acts parallel to the floor.

This allows the brush to evenly lean to the ground and perform its function properly.

Requirements: mounted brush, switched off machine.

6.2.1 MMx 50

MMx 50B

Procedure:

- Hook the brush and lower the scrub deck.
- Loosen the screw that secures the scrub deck to the left arm (see fig. 6.2.1-1).
- While holding up the left arm, tighten the screw at high edge of the adjustment slot.
- Adjust the knob for the direction adjustment (see fig. 6.2.1-2) so that in working conditions the brush aid the advancement of the machine.

Note: The factory setting foresees the thread of the adjustment rod flush with the knob brass insert.

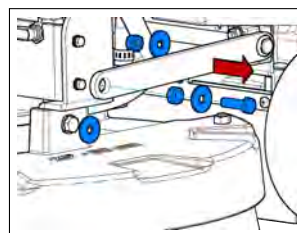

6.2.1-1

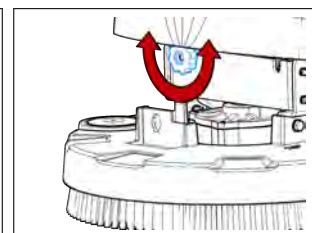

6.2.1-2

MMx 50BT

Procedure:

- Hook the brush and lower the scrub deck.
- Loosen the screw that secures the scrub deck to the upper right arm (see fig. 6.2.1-3).
- Move the machine so that the brush lies uniformly and parallel to the floor.
- Tighten the screw **flush with the self locking nut** to fix the adjustment.

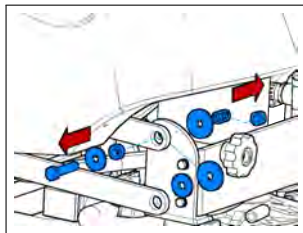

6.2.1-3

6.2.2 MMx 52

Procedure:

- Hook the brushes and lower the scrub deck.
- Loosen the screw that secures the scrub deck to the left arm (see fig. 6.2.2-4).
- Move the machine so that the brush lies uniformly and parallel to the floor.
- Tighten the screw to secure the flat adjustment of the scrub deck.

Belt Tension Spring Adjustment

Procedure:

- Disassemble the Brush Deck from the machine (see section 4.2.2 at page 22).
- Put the Brush Deck to let the motor Head touch the floor.
- Remove the brush deck lower carter (see fig. 6.2.2-5).
- Adjust the belt tension spring to bring it to about 27mm under compression (see fig. 6.2.2-6).

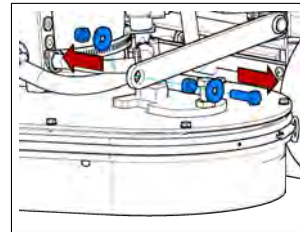

6.2.2-4

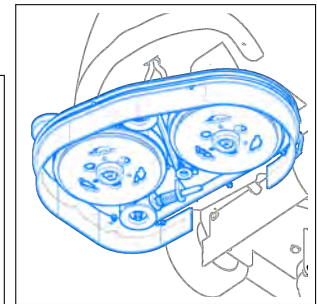

6.2.2-5

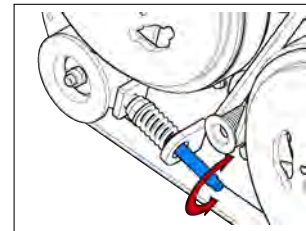

6.2.2-6

6.3 Maintenance and checks

6.3.1 Motor

Check (to perform every 150h)

Remove the brush/es.

Slightly lift the brush deck and turn on the motor; **the current absorption** measured on the single motor must be less than **2,7 Amps** (MMx 50) and less than **5,5 Amps** (MMx 52).

The motor should rotate evenly and smoothly and doesn't have to produce unusual noises. The motor contacts have to be clean, they have not to show signs of wear or heating in general.

The motor wires insulation has to be intact in all its parts and does not show signs of cracks. The single cable have to be flexible.

The carbon brushes must be 4-6 mm long and they have not to be abnormally worn out.

Maintenance (to perform every **600h**)
Motor carbon brushes replacement:
Procedure:

- Secure the machine.
- Remove the scrub deck from the machine.



- Loosen the screws that secure the collar brush guard.

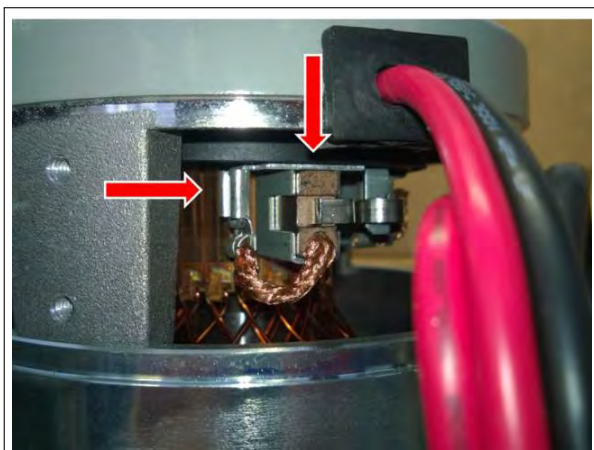

- Unscrew the Carbon brushes connector from the input power line to the motor.

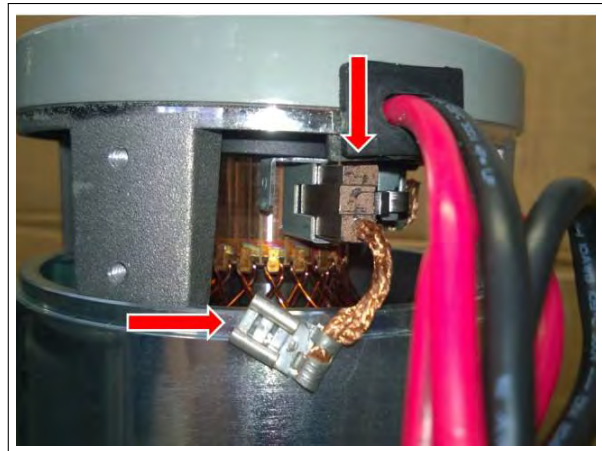

- Replace the carbon brushes being careful not to ruin them during assembly.
- Proceed to the reverse operations to reassemble it all.

6.3.2 Brass bushings

Check (to perform every **150h**)

The brass bushings allow a fluid and little tiring rotational movement of the brush deck. To prevent the deck is locked in a position without the possibility of movement, is important that the brass bushings are in good condition and clean. In case of excessive wear it is necessary to proceed with the replacement.

Maintenance (to perform every **900h**)

Brass bushings replacement:
Procedure:

- Secure the machine.
- Remove the screws that secure the brush deck to the machine body.
- Remove the brush deck from the machine.
- Remove the bushings and replace them with new bushings.

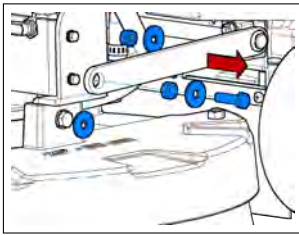

6.3.2-7 MMx50

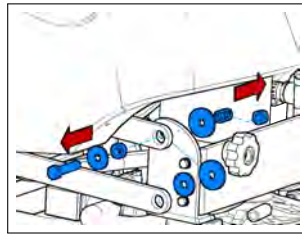

6.3.2-8 MMx50

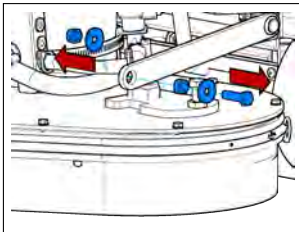

6.3.2-9 MMx52

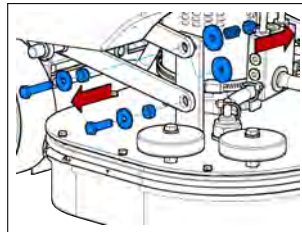

6.3.2-10 MMx52

- Proceed to the reverse operations to reassemble it all, sprinkle the new bushings with lubricating grease before mounting.
- Adjust to the brush deck once finished.

6.3.3 Bumping Wheel

Check (to perform every 150h)

The bumping wheel must be free to rotate and its diameter must not be too small due to wear. A bumping wheel in poor condition can lead to cracking of the brush deck when working skimming some obstacles (walls, shelving, etc).

If necessary, replace it (see section 4.2.8 at page 25) (see section 4.2.9 at page 25).

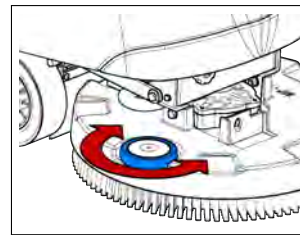

6.3.3-11 MMx 50

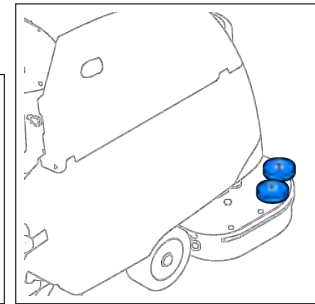

6.3.3-12 MMx 52

6.3.4 Brush Deck

Check (to perform every 150h)

The brush deck must be kept clean and intact. A ruined deck may be dangerous to the machine and the operator that uses it.

If necessary, replace it.

6.3.5 Brush coupling flange

Check (to perform every 150h)

The brush coupling flange is of plastic material and is not subject to particular wear. Like the other components its cleanliness is essential to allow the brush to engage and disengage smoothly. It is also essential that the brush locking spring has full functionality in order to keep the brush in the correct position. If necessary, replace it (see section 4.2.3 at page 23) (see section 4.2.4 at page 23).

6.4 Technical Features

TECHNICAL DESCRIPTION	U/M	MMx 50	MMx 52
Maximum diameter of the active part of the brush	ϕ mm	510	490
Brush turns	rpm	150	275
Brush motor voltage	V	24	24
Brush motor power	W	500	400
Max weight on brush	kg	20	23

6.5 Consumable Spare Parts

MMx 50					
PN	Description	ϕ (mm)	Bristle	ϕ Bristle (mm)	Colour
404654	BRUSH PPL 0,3	508	PPL	0,3	Blue
405631	BRUSH PPL 0,6	508	PPL	0,6	White
404653	BRUSH PPL 0,9	508	PPL	0,9	Black
405632	BRUSH TYNEX	508	ABRASIVE	0,9	Gray
405527	PAD HOLDER	475	-	-	-
Carbon Brushes					
422462	BR.MOT.CARBON BR.	-	-	-	-

MMx 52					
PN	Description	ϕ (mm)	Bristle	ϕ Bristle (mm)	Colour
405601	BRUSH PPL 0,3	255	PPL	0,3	Blue
405604	BRUSH PPL 0,6	255	PPL	0,6	White
405602	BRUSH PPL 0,9	255	PPL	0,9	Black
405603	BRUSH TYNEX	255	ABRASIVE	0,9	Gray
405513	PAD HOLDER	255	-	-	-
Carbon Brushes					
415982	BR.MOT.CARBON BR.	-	-	-	-

6.6 Recommended Spare parts

PN	Description	MMx	
		50	52
223301	GEAR MOTOR 24V 500W 140RPM MOLEX	✓	
436120	BUMPER WHEEL D=100 H=20	✓	
407716	MOTOR 24V 400W 2300G		✓
405708	BUMPER WHEEL D=80 L=23		✓

Chapter 7

Drying System

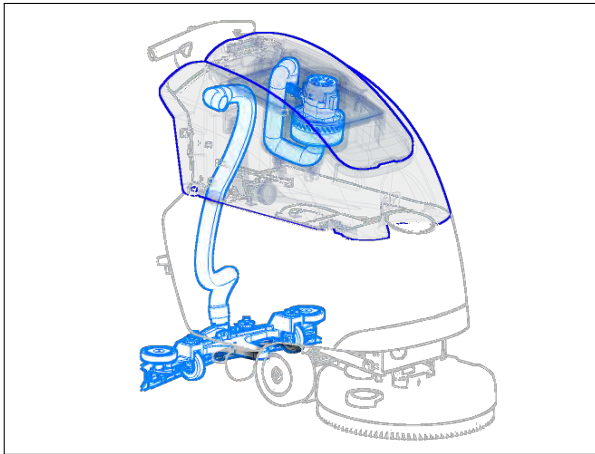

7.1 Structure

- Squeegee
- Squeegee adjustment
- Vacuum Hose
- Recovery Tank
- Filter and Floating
- Vacuum Manifold
- Vacuum Motor

7.2 Description

The machine dries the floor using an integrated Drying System.

After the washing, the solution used with the mechanical action of the brush to remove the dirt, is collected by a system which vacuum it out from the floor.

The system is basically made by a vacuum motor which produces a vacuum in the system. This vacuum causes an air flow which flows in the whole vacuum circuit.

The air that flows in the squeegee (when it is lowered on the floor) allows it to collect the water on the floor mixing it with the water and, via the vacuum system, is brought to the recovery tank.

In the recovery tank the water mixed with the dirt stops and the air keep flowing throughout the circuit reaching the vacuum motor and being **discharged** in the environment.

7.3 Adjustments

7.3.1 Squeegee Support

The Squeegee Support has to be adjusted with the Squeegee fitted on, lowered on the floor and vacuum system on. The goal of the adjustment is to let the squeegee blade be angled 45 degrees to the floor for its whole length.

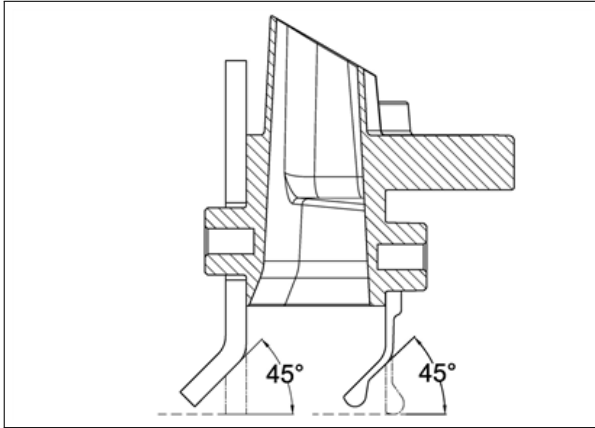

To obtain the proper squeegee adjustment act on the wing nuts to adjust the wheels of the squeegee support to obtain the proper height of the squeegee from the floor (see fig. 7.3.1-13) and the inclination screw to let the blade be bended equally for its whole length (see fig. 7.3.1-14).

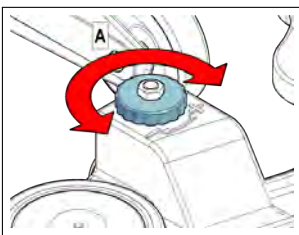

7.3.1-13 Height/Pressure

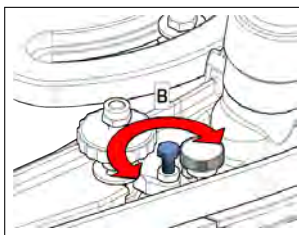

7.3.1-14 Inclination

Procedure

- Lower the squeegee on the floor with the rubber blades in vertical positions.
- Adjust the wheel of the squeegee support through the fixing screw (see fig. 7.3.1-13) until the wheels are lifted 2 mm from the floor $\pm 0,1\text{mm}$ (eventually help the adjustment with a spacer of that thickness).
- After having fixed the wheel, switch on the machine, advance slowly in working condition and act on the inclination screw (see fig. 7.3.1-14) in order to let the blade be equally angled for its whole length.
- Check the obtained adjustment with a functional test.

7.4 Maintenance and Checks

7.4.1 Squeegee

Check (to perform every 4h)

To have a good performance of the squeegee the blades have to be in a good conditions. The squeegee chamber and the squeegee adapter have to be clean and completely free from debris. Blades have to adhere perfectly to the squeegee body and have to be kept in that position by the plastic blade holder which are kept by the plastic wing nuts.

Maintenance (to perform every 45h)

- Put the machine in safe conditions.
- Remove the squeegee from the machine
- Rotate the wing nut that block the blade holders (see fig. 7.4.1-15)

- Remove the blade holder (see fig. 7.4.1-17)
- Remove the front blade and replace it with a new one (see fig. 7.4.1-19)
- Repeat the same operations for the rear blade. The rear blade can be used 4 times (one for each edge) before being replaced.
- Proceed at reverse to reinstall properly the blade holders.

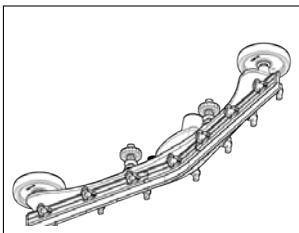

7.4.1-15 Front

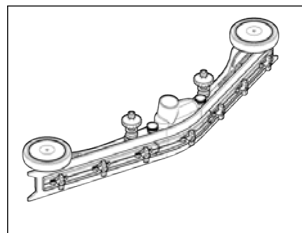

7.4.1-16 Rear

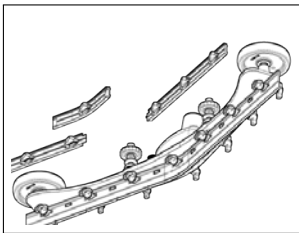

7.4.1-17 Front

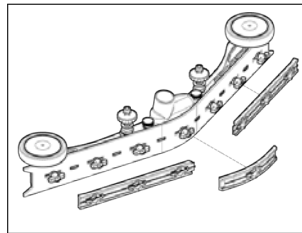

7.4.1-18 Rear

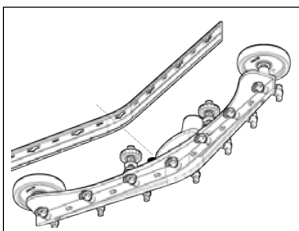

7.4.1-19 Front

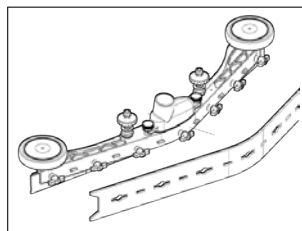

7.4.1-20 Rear

7.4.2 Squeegee Support

Check (to perform every 150h)

The squeegee support has to be completely free to move to lie perfectly on the floor. It is important that it can rotate freely and it is properly pressed on the floor by the spring.

Maintenance (to perform every 600h)

- Put the machine in safe conditions.
- Remove the squeegee from the squeegee support (see fig. 7.4.2-21), (see section 4.3.1 at page 26).

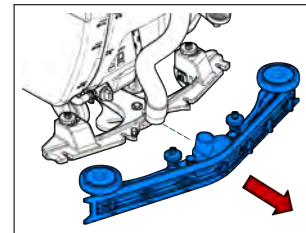

7.4.2-21 Squeegee Removal

- Remove and replace the squeegee support wheels loosening the adjustment wing nuts (see fig. 7.4.2-22) and the squeegee wheels screws (see fig. 7.4.2-23), (see section 4.3.5 at page 27).

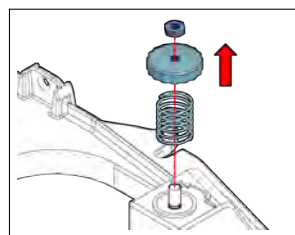

7.4.2-22 Adjustment Wing Nut Removal

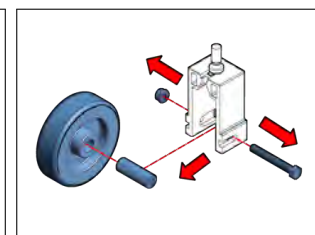

7.4.2-23 Blocking Screw Removal

- Proceed at reverse to reinstall the parts.
- During the assembly lubricate the squeegee support eyelet.

- At the end of the assembly perform the proper squeegee adjustment (see fig. 7.3.1-13), (see fig. 7.3.1-14).

7.4.3 Vacuum Hose

Check (to perform every 4h)

The vacuum hose has to be clean and intact (see fig. 7.4.3-24), (see fig. 7.4.3-25). It is mandatory that the hose has no crack to not decrease the vacuum. To verify the vacuum hose goodness turn on the vacuum motor and block the lower part of the hose with the hand, in this way there must be no air passage.

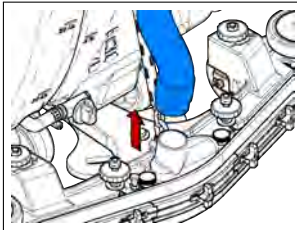

7.4.3-24 Vacuum Hose

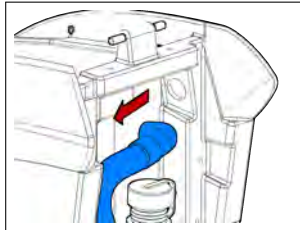

7.4.3-25 Vacuum Hose

7.4.4 Filter and Floater

Check (to perform every 4h)

The filter has to be clean and it is important that nothing blocks or reduces the floater mobility. The filter has to be clean to avoid that water or dirt goes inside the vacuum motor, the floater has to be free to move and has to block completely the air flow when it is in blocking position (UP).

Maintenance (to perform every 4h)

- Put the machine in safe conditions.
- Check that the recovery tank is completely empty.
- Lift the Recovery tank.

- Loose the filter protection and remove the filter (see fig. 7.4.4-26). Verify that the filter ball is free to move and intact.

- Remove and clean (replace if necessary) the filter.

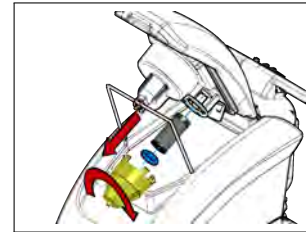

7.4.4-26 Filter Cup and Ball Filter

7.4.5 Recovery Tank

Check (to perform every 150h)

The recovery tank has to be clean and has not to have cracks or, in general, any kind of damage. The Lid housing has to be even and flat to allow the gasket to adhere perfectly to the tank to avoid any air infiltration. The hose fittings have to be in optimum condition in order to avoid any dirty water leakage or any pressure drop during the job.

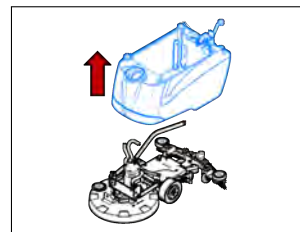

7.4.5-27 Recovery Tank

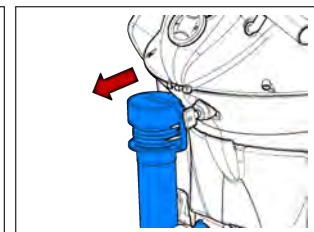

7.4.5-28 Drain Hose

7.4.6 Vacuum Motor

Check (to perform every 150h)

The vacuum motor with the vacuum hose disconnected from the squeegee has to **absorb** less than **14 Amps**.

The motor should rotate evenly and smoothly and doesn't have to produce unusual noises. The motor contacts have to be clean, they have not to show signs of wear or heating in general.

The motor wires insulation has to be intact in all its parts and does not show signs of cracks. The single cable have to be flexible.

The magnetic circuit of the motor has to be in good conditions and clean.

The carbon brushes must be 6-8 mm long and they have not to be abnormally worn out.

Maintenance (to perform every 450h)

- Put the machine in safe conditions.
- Disassemble the motor from the machine (see section 4.3.11 at page 29).
- Remove the cooler fan plastic cover from the motor (see fig. 7.4.6-29).
- Slip off the motor carbon brushes (see fig. 7.4.6-30)
- Replace the worn out carbon brushes with new ones.
- Proceed at reverse to restore the parts.

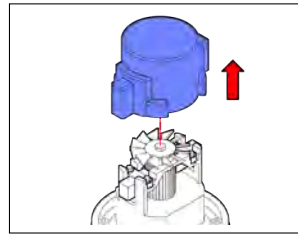

7.4.6-29 Plastic cover removal

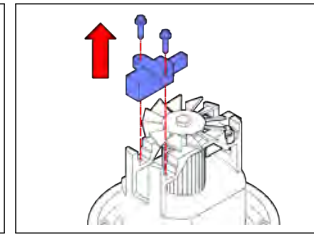

7.4.6-30 Carbon brush removal

7.4.7 Drain Hose

Check (to perform every 4h)

The Drain Hose has to be perfectly fitted in the recovery tank fittings. The Drain Cap (see fig. 7.4.7-31) has to seal perfectly the hose to avoid any pressure drop or dirty water leakage. The Drain Flexible Manifold has to be flexible and has to have no cracks to avoid any break down during the bending to drain the machine.

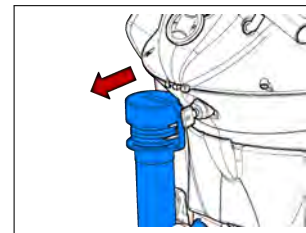

7.4.7-31 Drain Hose

7.5 Technical Features

TECHNICAL DESCRIPTION	U/M	MMx 50	MMx 52
Squeegee width	mm	700	700
Optional Squeegee width	mm	800	800
Recovery Tank	l	50	50
Vacuum Motor Stages	Nr	2	2
Vacuum Motor Power	W	310	310
Vacuum Motor Voltage	V	24	24
Vacuum Motor Depression	<i>mmH₂O</i>	610	610

7.6 Consumable Spare Parts

PN	Description
700 mm Squeegee	
219451	SQUEEGEE BLADES KIT 33 SHORE
219452	SQUEEGEE BLADES KIT 40 SHORE PU
219453	SQUEEGEE BLADES KIT LATEX
438487	SQ. SUPPORT WHEEL D=80 H=25
800 mm Optional Squeegee	
221391	SQUEEGEE BLADES KIT 33 SHORE
221392	SQUEEGEE BLADES KIT 40 SHORE PU
221393	SQUEEGEE BLADES KIT LATEX
438487	SQ. SUPPORT WHEEL D=80 H=25
Carbon Brushes	
424210	VACUUM MOTOR CARBON BRUSHES

7.7 Recommended Spare Parts

PN	Description	MMx	
		50	52
436120	BUMPER WHEEL D=100 H=20	✓	✓
430957	STRAIGHT ADAPTER D=40	✓	✓
219723	VACUUM MOTOR	✓	✓
400727	FLOATER PROTECTION	✓	✓
412363	CARTRIDGE FILTER ASSEMBLY D=60 H=130	✓	✓
432150	VACUUM HOSE D=38 L=1310 SPIR. W/ELBOW	✓	✓

Chapter 8

Machine Frame and Traction System

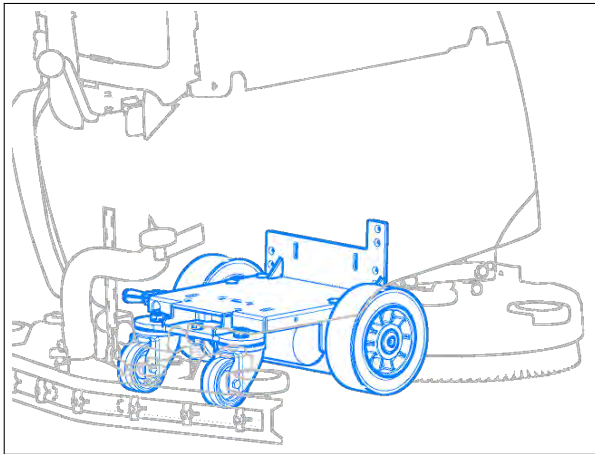

8.1 Structure

- Frame
- Front Wheels
- Rear Wheels
- Parking Brake Lever
- Traction Motor (BT only)

8.2 Description

The frame is a single structure on which are coupled the traction system (BT only) and the tanks group.

In the semi automatic models the machine traction is ensured by the mechanical friction system;

in the BT version the machine traction is given by the electric motor installed in conjunction with a reduction gear, whose output shafts act directly on the machine front wheels, ensuring traction.

All models has a parking brake that acts on the front left wheel through a control lever.

All models are fitted with mixed antiskid / non-marking wheels.

8.3 Adjustments

8.3.1 Parking Brake Lever

The lever (see fig. 8.3.1-32) have to be adjusted to ensure the proper arrest of the machine once it is fully pressed on the drive wheel.

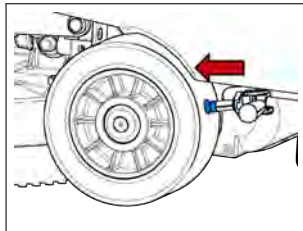

8.3.1-32 Parking Brake Lever

Procedure

- Secure the machine.
- Unscrew the adjusting nut, in order to have approx 7 mm clearance between the stopper screw and the wheel.
- Check the correct operation of the parking brake.
- Lock the adjusting nut.

8.4 Maintenance and Checks

8.4.1 Wheels

Check (to perform every 150h)

The wheel must be free to rotate smoothly without friction. The wheel surface, must always be in good condition.

Maintenance (to perform every 600h)

Periodically check the condition of the bearings and bushings of the wheels. If necessary, replace the part (see section 4.4.1 at page 31).

8.4.2 Traction Motor (BT only)

Check (to perform every 150h)

Lift one of the two front wheels and activate the traction, the current absorption measured on the traction motor must be less than **3 Amps**.

ATTENTION – At the start and when accelerating the absorption current of the motor is much higher.

The motor should rotate evenly and smoothly and doesn't have to produce unusual noises. The motor contacts have to be clean, they have not to show signs of wear or heating in general.

The motor wires insulation has to be intact in all its parts and does not show signs of cracks. The single cable have to be flexible.

The carbon brushes must be 4-6 mm long and they have not to be abnormally worn out.

Maintenance (to perform every **600h**)

Replacement of traction motor Carbon Brushes:

Procedure:

- Secure the machine.
- Remove the traction unit from the machine (see section 4.4.4 at page 31).
- Mark the correct positioning of the motor hood before proceeding in the operation

- Remove the connectors that fix the carbon brushes to the mains supply and remove the carbon brushes from the body of the hood (do not miss the compensating ring) (see fig. 8.4.2-36).
- Replace the carbon brushes being careful not to ruin them during assembly (see fig. 8.4.2-37).
- Proceed to the reverse operations to reassemble everything.

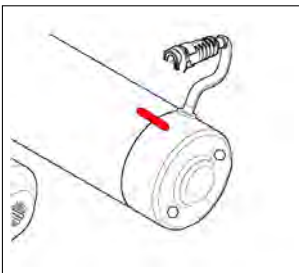

8.4.2-33 Motor Hood Positioning

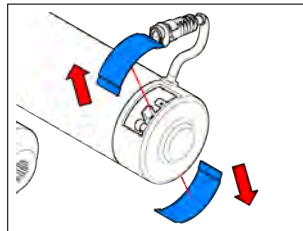

8.4.2-34 Side Covers

- Remove the plastic side covers and unscrew the screws that secure the hood to the motor (see fig. 8.4.2-34), (see fig. 8.4.2-35).

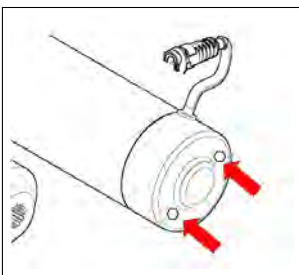

8.4.2-35 Fixing Screws

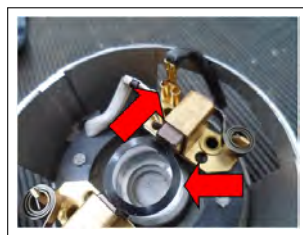

8.4.2-36 Ring

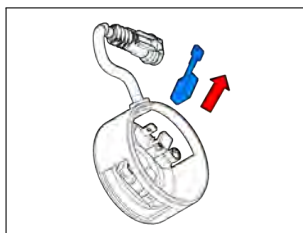

8.4.2-37 Carbon Brushes removing

8.5 Technical Features

TECHNICAL DESCRIPTION	U/M	MMx B	MMx BT
Traction motor Voltage	V		24
Traction motor Power	W		150
Maximum working forward speed	km/h		2.7
Maximum transfer forward speed	km/h		3.9
Maximum reverse speed	km/h		2.1
Traction wheel (num/diam/width)	(Nr/ ϕ mm/mm)	2/175/60	2/175/60
Traction wheel material		Thermoplastic Polyurethane	
Traction wheel hardness	Sh	80	80

8.6 Consumable Spare Parts

PN	Description	MMx B	MMx BT
436222	FRONT WHEEL D=175 d=20 S=60 WITH BEARINGS	✓	
438029	FRONT WHEEL D=175 d=20 S=60 SPLINED HUB		✓
424462	REAR WHEEL D=80 H=32 CUSCIN. INOX	✓	✓
Carbon Brushes			
409413	TRACTION MOTOR CARBON BRUSHES		✓

8.7 Recommended Spare Parts

PN	Description	MMx B	MMx BT
223329	TRACTION MOTOR 24V 150W		✓

Chapter 9

Cleaning Solution Supply System

9.1 Description

The Cleaning Solution Supply System is made by a tank commonly called solution tank or clean water tank.

In this tank the clean water is mixed with the detergent to create the cleaning solution that the machine will use to clean.

The Dosing system versions keep the chemical in a separate tank, and the dilution may be adjusted directly by the operator via the knobs on the dashboard.

The solution is then canalized to the filter and the water valve. **The filter** is used to stop debris that could stuck the hose system and compromise the proper functioning of the system, **the water valve** is used to adjust the solution that will fall on the floor in order to have the correct amount of solution required for washing.

Once passed through the water valve the solution arrive to the solenoid valve that blocks the delivery when the brush is not working and allow the flow while brush works.

The end of the solution path is the distributor that canalizes the flow in the middle of the brush.

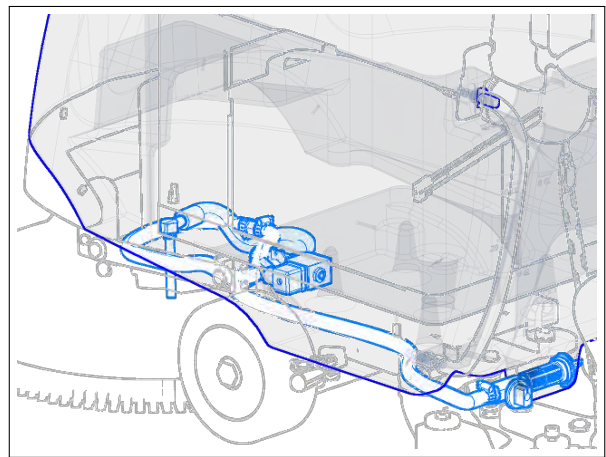

9.2 Structure

- Solution Tank
- Hoses
- Water Valve
- Solution Filter
- Solenoid Valve
- Distributor

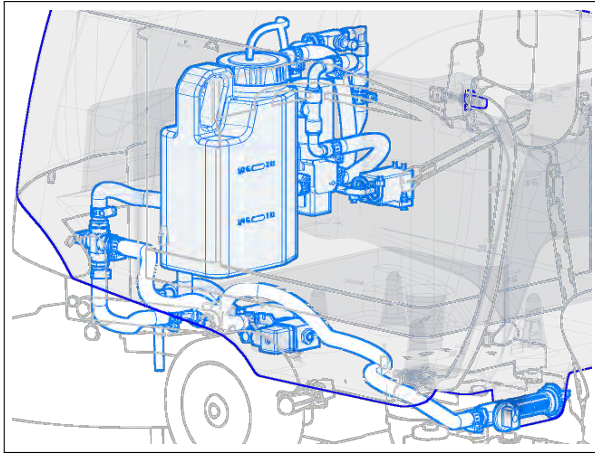

9.3 Dosing System Structure

- Solution Tank
- Chemical Tank
- Hoses
- Water Valve
- Solution Filter
- Bypass Valve
- Flojet Pump
- Membrane Pump
- Solenoid Valve
- Distributor

9.4 Maintenance and Checks

9.4.1 Solution Tank

Check (to perform every **50h**)

The solution tank has to be clean and intact. It has not to have cracks or any other kind of damage. Verify, when the tank is completely filled up, that there are not leakage. If necessary replace the Solution Tank. (see section 4.5.1 at page 32).

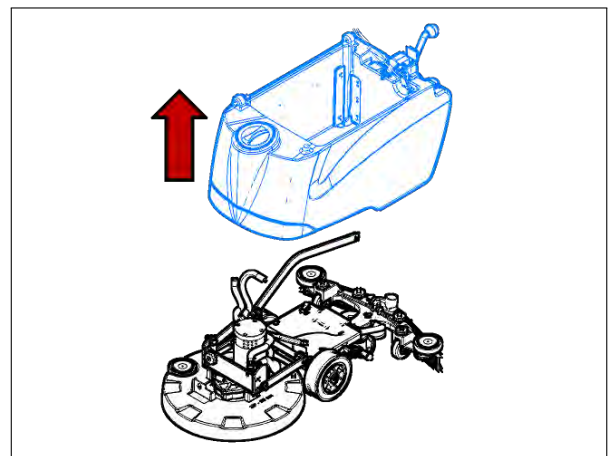

Figure 9.1: Solution Tank

9.4.2 Chemical Tank (DS only)

Check (to perform every **50h**)

The chemical tank has to be clean and intact. It has not to have cracks or any other kind of damage. Verify, when the tank is completely filled up, that there are not leakage. The cap must have a good seal and the float must be well positioned on the bottom of the tank. If necessary replace the chemical Tank. (see section 4.5.1 at page 32).

9.4.3 Hoses

Check (to perform every 50h)

Every single hose has to be intact and has not to be worn out. It is extremely important that the hoses kept the original flexibility and they haven't suffered any chemical reaction with the detergent used with the machine. If necessary proceed with the replacement of the damaged hoses (see section 4.5.2 at page 33).

9.4.4 Water Valve

Check (to perform every 50h)

It is extremely important that when adjusted at minimum the valve blocks completely the water flow and it is mechanically free to move for its while stroke.

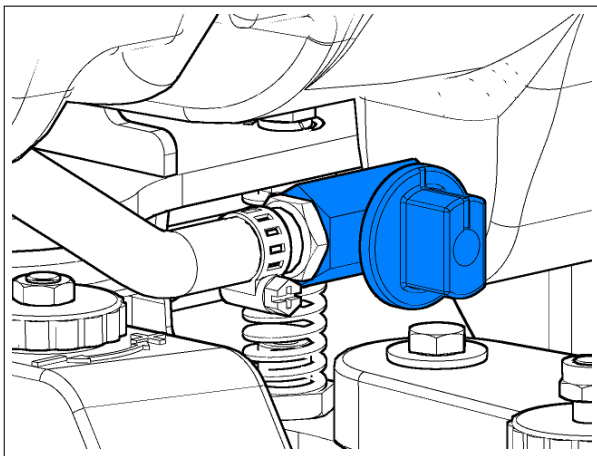

Figure 9.2: Water Valve

9.4.5 Clean Water Filter

Check (to perform every 4h)

The filter has to be periodically cleaned. When it is fitted on the machine no leakage has to be present. The filter cartridge has to be intact and has not to present any anomaly.

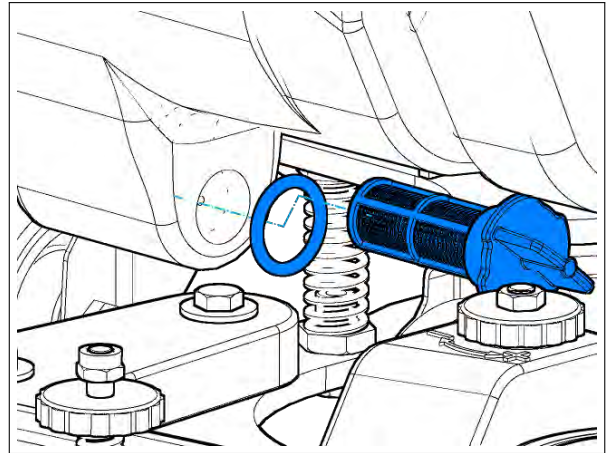

Figure 9.3: Clean Water Filter

9.4.6 Bypass Valve (DS only)

Check (to perform every 50h)

It is extremely important that when closed the valve blocks completely the water flow and it is mechanically free to move for its while stroke.

9.4.7 Flojet Pump (DS only)

Check (to perform every 50h)

It is important to Verify that the pump is able to provide a regular water flow from the solution tank.

9.4.8 Membrane Pump (DS only)

Check (to perform every 50h)

It is important to Verify that the pump is able to provide a regular chemical flow from the chemical tank.

ATTENTION: To check its operation measure the voltage in **Alternate Current**.

9.4.9 Solenoid Valve

Check (to perform every 50h)

The solenoid valve has to block completely the solution flow when the brush deck is not working. Vice versa it has to grant the full flow rate when the brush deck is working.

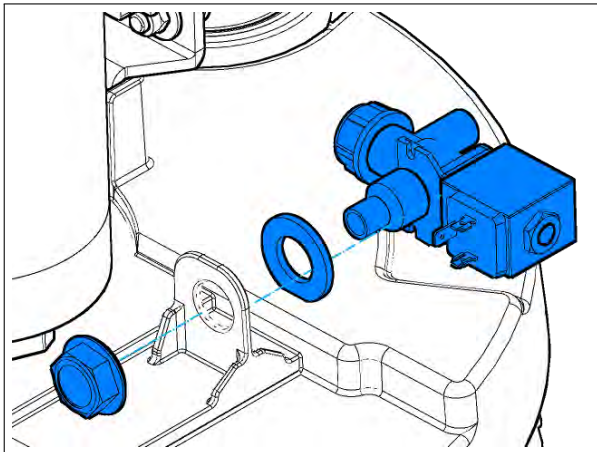

Figure 9.4: Solenoid Valve

9.4.10 Distributor

Check (to perform every 150h)

The distributor has to be intact and has to grant the proper solution flow without any leakage in the gearbox.

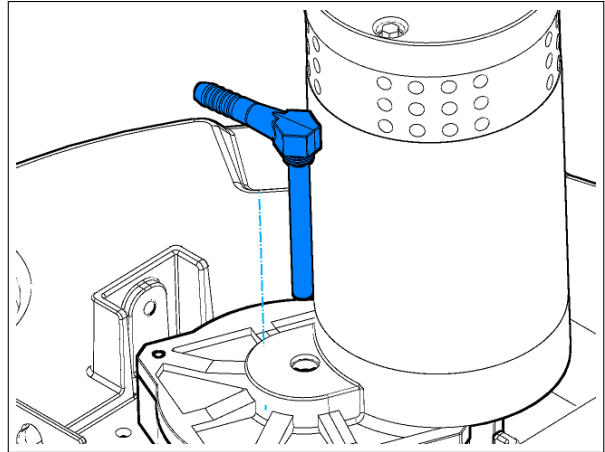

Figure 9.5: Distributor

9.5 Technical Features

TECHNICAL DESCRIPTION	U/M	MMx	MMx DS
Solution Tank	1	40	40
Chemical Tank	1		3
Water Valve		Steel ball valve	Steel ball valve
Clean Water Filter		Plastic cartridge	Plastic cartridge
Bypass Valve			Steel ball valve
Flojet Pump	V		Alternate Current

9.6 Recommended Spare Parts

PN	Description	MMx	MMx DS
222092	FILTER D=23 H=53 PLUG 3/4 WING NUT	✓	✓
424451	GASKET OR 4100	✓	✓
414646	COMPLETE SOLENOID 24V	✓	✓
424792	FLOJET PUMP 12V		✓
426416	MEMBRANE PUMP 24V		✓

Part IV
Accessories and Add-On

Chapter 10

Accessories

10.1 Accessories List

- On board Charger Kit

10.2 On board Charger Kit - 437657

10.2.1 Description

The machine is available in "CB" version which is the version with the built in charger. Anyway, in a standard machine without the built in charger, it is possible to install the charger afterward by following the below instructions.

10.2.2 Part Numbers List

- 1 x 437657 Charger 24V 11A
- 4 x 408870 Screw D.3,9X10

10.2.3 Machine Preparation

Before to start the kit installation is mandatory to put the machine in safe condition. Release the brush, engage the parking brake and unplug the battery connector.



10.2.3-1 Machine switching off

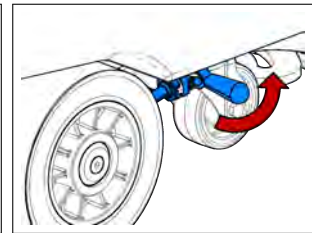

10.2.3-2 Parking brake



10.2.3-3 Unplug of battery connector

10.2.4 Installing instructions

- Make sure that the set up of the charger matches the type of battery actually installed on the machine (see section 5.4.3 at page 43).
- Open the upper handle by removing the screws.
- Remove the hinge and the door of the glove compartment.
- Cup Drill ϕ 21mm on the upper right side of the glove compartment to let the cables pass.
- Remove 5 cm of sheath from wires of the charger.
- Insert the wires of the charger into the hole by passing the male faston for first, and guide them into the electrical system.
- Tighten the screws on the left side of the charger and then tighten the right side screws.



10.2.4-4 Hole

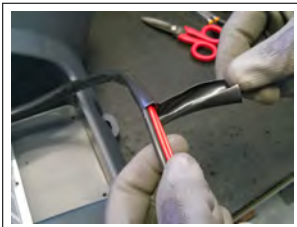

10.2.4-5 Sheath



10.2.4-6 Wires Pass



10.2.4-7 Tightening

- Connect the battery charger cables.¹:
 - Connect the charger power wires to the cables "XCB" of the machine harness.
 - Connect the charger safety wires to the cables "XCBR" of the machine harness.
 - Bundle the cables with clamps.



10.2.4-8 Power wires



10.2.4-9 Safety wires



10.2.4-10 Clamp

- Restore the hinge and the door of the glove compartment.
- Close the upper handle by tightening the screws.
- Perform a functional test.
- After the functional test, the power cable can be fit at the side of the charger, inside the glove compartment.

¹Refer also to the Electric Scheme



Fimap S.p.A.
Workshop Handbook MMx B/BT

Fimap S.p.A. Via Invalidi del Lavoro, 1 - 37059 S.Maria di Zevio Verona - ITALY
Tel. +39 045 6060411 - Fax +39 045 6060417
Edition: November 14, 2014